



# S4052 Series Signal/spectrum analyzer User Manual



This manual applies to the following models of signal / spectrum analyzers:

S4052A signal/spectrum analyzer (2 Hz ~ 4 GHz)

S4052B signal/spectrum analyzer (2 Hz ~ 8GHz)

S4052C signal/spectrum analyzer (2 Hz ~ 13.6 GHz)

S4052D signal/spectrum analyzer (2 Hz ~ 18 GHz)

S4052E signal/spectrum analyzer (2 Hz ~ 26.5 GHz)

S4052F signal/spectrum analyzer (2 Hz ~ 40 GHz)

S4052G signal/spectrum analyzer (2 Hz ~ 45 GHz)

S4052H signal/spectrum analyzer (2 Hz ~ 50 GHz)

Besides the standard accessories, the S4052 series signal/spectrum analyzers provide the following options:

S4052-H02 HF-IF output Output frequency range: 275MHz ~ 475MHz, 750MHz and other secondary IF signal, step resolution: 1Hz. (According to standard configuration, 400MHz option, and 1.2GHz option).

S4052-H08, broadband logarithmic detection output: output logarithmic detection signals reflecting the level characteristics of the input signal.

S4052-H11 10 Gigabit network control and data interface: Optical fiber-based 10 Gigabit network interface;

S4052-H17-E CPU enhancement Upgrade to an Intel I7 processor to enhance CPU processing capability and improve measurement speed.

S4052-H19-2T Local storage space expanding Support storage space of up to 2TB (electronic hard disk).

S4052-H19-4T Local storage space expanding Support storage space of up to 2TB (electronic hard disk).

S4052-H33-08, electronic attenuator: a frequency range of 9kHz ~ 8GHz, attenuation range of 30 dB with a 1 dB step.

S4052-H34-04, S4052-H34-08, S4052-H34-13, S4052-H34-18, S4052-H34-26, S4052-H34-40, S4052-H34-45, S4052-H34-50, low noise preamplifier: supporting low-band preamplifier or full-band amplifier. (The low-band preamplifier is numbered H34-08, and the full-band preamplifier is selected according to the upper frequency limit of the selected signal analyzer host; for example, the frequency limit of the S4052E is 26.5GHz, the full-band preamplifier of H34-26 shall be selected).

S4052-H36, preselector bypass: bypass the tracking preselector in the receiving channel.

S4052-H38-40, 40 MHz analysis bandwidth: supports analysis bandwidths ranging from 10 Hz to 40 MHz.

S4052-H38-200, 200 MHz analysis bandwidth: supports analysis bandwidths ranging from 10 Hz to 200 MHz.

S4052-H38-400, 200 MHz analysis bandwidth: supports analysis bandwidths ranging from 10 Hz to 200 MHz.

S4052-H38-600, 200 MHz analysis bandwidth: supports analysis bandwidths ranging from 10 Hz to 200 MHz.

S4052-H38-1200, 200 MHz analysis bandwidth: supports analysis bandwidths ranging from 10 Hz to 200 MHz.

S4052-H39, audio analysis: implement the audio signal parameter test, distortion test and waveform analysis.

S4052-H40, external frequency extension: provide the ability to extend the frequency test range using external mixing methods.

This option will be provided with local oscillator output and IF input interface functions, and provide signal recognition capability (This option is optional only when the host model is not S4052A/B; the extended frequency range depends on the selected spread spectrum module. Spread spectrum modules need to be purchased separately).

S4052-H41-200, S4052-H41-400 real-time spectrum analysis: provide digital fluorescent spectrum and seamless spectrogram functions, including frequency template triggering, and support the real-time spectrum analysis of bandwidth.

S4052-H48, noise factor test: provide the noise source driver and noise factor test function. (Note: When selecting this option, H34 low-noise preamplifier option corresponding to the whole frequency band and corresponding 1660X noise source probe need to be purchased at the same time to jointly complete the noise figure test function.)

S4052-H96, User's Manual (paper version), provides a detailed user's manual in paper form.

S4052-H97, racking kits: include the racking handle and accessories that are used to rack and install the S4052 series in the standard cabinets.

S4052-H99, aluminum alloy transport case: adopt the high strength lightweight aluminum alloy transport case, with handles and casters, easy to transport.

S4052-S02 Noise-to-power ratio test provides noise-to-power ratio test capability.

S4052-S04, phase noise test: provide the single sideband phase noise curve and single point phase noise test capability.

S4052-S05 EMC pre-compatibility testing provides EMI pre-compatibility testing capabilities.

S4052-S10 transient analysis: test and analyze the instantaneous parameter spectrum, frequency spectrum and time-varying characteristics of signals, and supports the playback of recorded data.

S4052-S12, vector signal analysis: provide flexible demodulation for a variety of single carrier digital modulation signals, provide rich diagrams like the vectogram, constellation chart, eye diagram, and spectrogram for the analysis of the modulation signal characteristics, and can obtain the signal modulation error through demodulation, helping to determine the cause of the signal error. S4052-S13, pulse signal analysis: implement automatic measurement of the pulse waveform time, level and modulation parameters and statistical analysis of the pulse train.

S4052-S16 Multicarrier group delay measurement provides the absolute and relative group delay measurement ability of broadband signals.

S4052-S40 WLAN 802.11a/b/g measurement Support 802.11a/b/g standard OFDM signal modulation analysis, as well as 802.11a/b/g single carrier DSSS, CCK and PBCC signal modulation analysis, with constellation chart, error summary, time domain capture, EVM Vs. carrier, gain imbalance Vs. carrier, orthogonal error Vs. carrier and other trace output; the error summary covers EVM, frequency error, origin offset, gain imbalance, orthogonal error, average power, peak-to-average ratio and other error parameters output.

S4052-S40N WLAN 802.11n measurement supports 802.11n standard 20 MHz and 40 MHz bandwidth signal modulation analysis, and has trace outputs such as constellation, error summary, time domain capture, EVM Vs. Carrier, gain imbalance vs. carrier, orthogonal error vs. carrier, etc. The error summary covers the output of error parameters such as EVM, frequency error, origin offset, gain imbalance, quadrature error, average power and peak-to-average ratio.

S4052-S40AC WLAN 802.11ac measurement supports 802.11ac standard 20 MHz/40 MHz bandwidth signal modulation analysis. The modulation modes include BPSK, QPSK, 16QAM, 64QAM, and 256QAM, and has trace outputs such as constellation, error summary, time domain capture, EVM Vs. Carrier, gain imbalance vs. carrier, etc. The error summary covers the output of error parameters such as EVM, frequency error, origin offset, gain imbalance, quadrature error, average power and peak-to-average ratio.

S4052-S40AX WLAN 802.11ac measurement supports 802.11ac standard 20 MHz/40 MHz/80 MHz/160 MHz bandwidth signal modulation analysis. The modulation modes include BPSK, QPSK, 16QAM, 64QAM, and 256QAM, and has trace outputs such as constellation, error summary, time domain capture, EVM Vs. Carrier, gain imbalance vs. carrier, etc. The error summary covers the output of error parameters such as EVM, frequency error, origin offset, gain imbalance, quadrature error, average power and peak-to-average ratio.

S4052-S46D 5G NR downlink signal measurement supports the modulation quality analysis of downlink CP-OFDM waveform signals in 5G NR Sub6G and mmWave frequency bands, and provides parameters such as EVM and frequency error of different symbols and different carriers; Supports Test Model test cases such as TM1.1, TM1.2, TM2, TM2a, TM3.1, TM3.1a, TM3.2, TM3.3, and realize one-key configuration of parameters; Supports modulation methods such as QPSK, 16QAM, 64QAM and 256QAM and signal bandwidths such as 5MHz, 10MHz, 15MHz, 20MHz, 30MHz, 40MHz, 50MHz, 60MHz, 70MHz, 80MHz, 90MHz, 100MHz, 200MHz and 400MHz; Supports subcarrier intervals such as 15kHz, 30kHz, 60kHz and 120kHz; supports automatic detection of cell ID, flexible configuration of frame structure and saving user-defined configuration.

S4052-S46U 5G NR upstream signal measurement Support the signal modulation quality analysis of upstream CP-OFDM and FDT-S-OFDM waveforms in 5G NR Sub6G CP and mmWave bands, and provide the EVM and frequency error results of different symbols and different carriers; support  $\pi/2$ -BPSK, QPSK, 16QAM, 64QAM, 256QAM and other modulation modes and such signal bandwidths as 5MHz, 10MHz, 15MHz, 20MHz, 25MHz, 30MHz, 40MHz, 50MHz, 60MHz, 70MHz, 80MHz, 90MHz, 100MHz, 200MHz and 400MHz ; support 15kHz, 30kHz, 60kHz, 120kHz and other sub-carrier intervals; support the flexible configuration of frame structures and the saving of user-defined configurations.

# Foreword

Thank you for choosing and using S4052 series signal/spectrum analyzer developed and produced by saluki Technologies Co., Ltd.!

We will take the responsibility to maximally meet your needs and provide you with high-quality measuring instruments and first-class after-sales service. We aim to provide "high quality and considerate service", and operate on the principle of making customers satisfactory with our products and services.

## Manual No.

AV2.732.1153SS

## Version

A.2 2024.08

saluki Technologies Co., Ltd.

## Manual Authorization

The contents of this manual are subject to change without notice. The contents and terms used in this manual are interpreted by saluki Technologies Co., Ltd.

The copyright of the manual belongs to saluki Technologies Co., Ltd, no modification can be made to the manual contents by any unit or person without approval of the company, and no

reproduction or propagation of the manual can be made for profits, otherwise, saluki Technologies Co., Ltd reserves the right of pursuing legal responsibilities from any infringer.

## Product warranty

The warranty period of this product is 18 months from the date of shipment. The network analyzer manufacturer will repair or replace the damaged components as required within the warranty period. For this purpose, the user shall return the product to the manufacturer and prepay the mailing fee. The manufacturer will return the fee to the user together with the product after maintenance.

## Product quality certificate

This product is guaranteed to meet the specifications in this manual from the date of shipment. The calibration and measurement are completed by measuring bodies with national qualification, with relevant data to be provided for reference by users.

## Quality/Environmental Management

This product complies with the quality and environmental management systems during R&D, manufacturing and testing. saluki Technologies Co., Ltd. is qualified and has passed ISO 9001 and ISO 14001 management systems.

## Safety Precautions



The symbol "Warning" indicates a hazard. It reminds the user to pay attention to a certain operation process, operation method or the like. In case of any failure of observing the rule or maloperation,

personal injury can occur. Proceed to the next step only after fully understanding and meeting the warning conditions indicated.

## NOTICE

Notice mark, indicating some important information which will not cause danger. It reminds the user to pay attention to a certain operation process, operation method or the like. Failure to observe the rules or operate correctly may cause damage to the instrument or loss of important data. Proceed to the next step only after fully understanding and meeting the caution conditions indicated.

# Table of Contents

1. Manual navigation .....	1
1.1. About the manual .....	1
1.2 Related Documents .....	2
● Online Help .....	2
● User's Manual .....	2
● Program Control Manual .....	2
● Manual Navigation .....	2
● Get Prepared .....	2
● Typical Applications .....	2
● Get Help .....	2
● Manual Navigation .....	2
● Overview .....	2
● Quick Start .....	2
● Operation Guide .....	2
● Remote Control .....	2
● Troubleshooting and Repair .....	2
● Technical Indicators and Testing Methods .....	2
● Annex .....	2
● Remote Control .....	2
● Program Control Commands .....	2
● Programming Examples .....	2
● Error Description .....	2
● Annex .....	3
2 Overview .....	4
2.1 Product Overview .....	4
2.2 Safe Operation Manual .....	4
2.2.1 Safety marks .....	4
2.2.2 Operation Status and Locations .....	6

Table of Contents

- 2.2.3 Electrical safety ..... 6
- 2.2.4 Operation Precautions ..... 7
- 2.2.5 Maintenance ..... 8
- 2.2.6 Batteries or power modules..... 8
- 2.2.7 Transportation ..... 8
- 2.2.8 Waste disposal/environmental protection ..... 9
- 3 Quick Start ..... 10**
- 3.1 Get prepared ..... 10
  - 3.1.1 Preparations before operation ..... 10
  - 3.1.2 Operating System Configuration ..... 19
  - 3.1.3 Routine Maintenance ..... 22
- 3.2 Front and Rear Panels ..... 23
  - 3.2.1 Front Panel ..... 24
  - 3.2.2 Rear Panel Description..... 27
- 3.3 Basic measurement methods ..... 30
  - 3.3.1 Basic Operation Instructions..... 30
  - 3.3.2 Basic Operation Examples..... 33
- 3.4 Data management ..... 36
  - 3.4.1 Storage/calling working status ..... 36
  - 3.4.2 Data Storage/Call..... 38
  - 3.4.3 Printing/Saving Screenshots..... 40
- 4 Operation Guide ..... 41**
- 4.1 Function Operation Guide ..... 41
  - 4.1.1 Introduction to Measurement Mode and Function ..... 41
  - 4.1.2 General Measurement Parameter Setting Guide ..... 42
  - 4.1.3 General Analysis and Display Function Guide ..... 66
- 4.2 Advanced Operation Guide ..... 72
  - 4.2.1 Measure Small Signal ..... 73
  - 4.2.2 Occupied Bandwidth ..... 78
  - 4.2.3 Adjacent Channel Power ..... 80
  - 4.2.4 Power Statistics ..... 82
  - 4.2.5 Burst Power ..... 84
  - 4.2.6 Harmonic distortion ..... 86

4.2.7 Third Order Intermodulation .....	88
4.2.8 Spurious Emission .....	89
4.2.9 Spectrum emission mask .....	90
<b>5 Remote Control .....</b>	<b>92</b>
5.1 Remote Control Basics .....	92
5.1.1 Remote Control Interface .....	92
5.1.2 Message .....	94
5.1.3 SCPI .....	95
5.1.4 Command Sequence and Synchronization .....	102
5.1.5 State Reporting System .....	103
5.1.6 Programming Precautions .....	105
5.2 Instrument Program Port and Configuration .....	105
5.2.1 LAN .....	105
5.2.2 GPIB .....	106
5.3 Basic VISA interface programming .....	106
5.3.1 Installing VISA Library .....	107
5.3.2 Initialize Controller .....	107
5.3.3 Initialize the instrument .....	107
5.3.4 Send Setting Command .....	107
5.3.5 Read the State of Measuring Instrument .....	108
5.3.6 Reading Marker (For Signal/Spectrum Analyzer) .....	108
5.3.7 Command Synchronization .....	108
5.4 I/O library .....	109
5.4.1 Overview of I/O Library .....	109
5.4.2 Installation and configuration of I/O library .....	110
<b>6 Troubleshooting and after-sales services .....</b>	<b>112</b>
6.1 Working Principles .....	112
6.1.1 Overall working principle and hardware function block diagram .....	112
6.2 Troubleshooting .....	114
6.2.1 Basic Troubleshooting Process .....	114
6.2.2 Common Faults and Troubleshooting Method .....	115
6.3 Error Message .....	119

Table of Contents

6.3.1 Error message Description ..... 119

6.4 Method to Obtain After-sales Services ..... 120

    6.4.1 Contact us ..... 120

    6.4.2 Package and mailing ..... 120

7 Technical indicators and testing methods ..... 121

7.1 Statement ..... 121

7.2 Product features ..... 122

7.3 Technical Specifications ..... 123

7.4 Additional information ..... 127

7.5 Performance characteristics test..... 127

7.5.1 Recommended testing method..... 127

    a) Description of the test items: ..... 128

    a) Description of the test items: ..... 129

50 Ω load ..... 147

x) Set power meter frequency to 5 GHz; ..... 155

**Third IF mirror response ..... 157**

**Second IF mirror response..... 157**

**First IF mirror response ..... 157**

    7.5.2 Interfaces ..... 158

    7.5.3 Performance Test Recording Sheet..... 159

    7.5.4 Auxiliary Test Table..... 189

    7.5.5 Recommended instrument for performance characteristics test..... 198

Annex ..... 201

Annex A Terminology ..... 201

    LO ..... 201

    Local oscillator feed-through..... 201

    Waveform factor ..... 201

    Units of measurement ..... 201

    Menus..... 201

    Ref Level..... 202

Table of Contents

Measuring range.....	202
Difference marker .....	202
Impact bandwidth.....	202
Bandwidth selectivity .....	202
Dynamic range .....	202
Logarithmic scale display .....	202
Spurious response .....	203
FFT.....	203
Resolution .....	203
Amplitude accuracy.....	203
Negative peak detection .....	203
Trace.....	203
Intermodulation .....	204
Active Function Zone .....	204
Detector Mode .....	204
Scale factor .....	204
Zero span.....	204
Drift.....	204
Freq Resp .....	205
Marker .....	205
Span .....	205
Frequency range:.....	205
Frequency accuracy .....	205
Frequency stability .....	205
Signal/spectrum analyzer .....	205
Flatness.....	205
Sample detection method .....	205
Swp Time .....	206
RF Attenuator .....	206
Residual FM.....	206
Video .....	206
VBW.....	206
Video amplifier .....	206

## Table of Contents

Video filtering and video averaging .....	206
Input amplitude range .....	207
Input impedance .....	207
Refresh mode .....	207
Display range.....	207
Explicit average noise level .....	207
Linear display .....	207
Relative amplitude precision .....	207
Preselector .....	207
Sensitivity .....	208
Noise marker .....	208
Phase noise (noise sideband).....	208
Harmonic mixing .....	208
Gain compression .....	208
Detector detection mode .....	208
Positive peak detection mode .....	209
IF gain/IF attenuation .....	209
Annex B Zoom table of SCPI commands .....	210
<a href="#">Annex C Zoom table of failure information</a> .....	286

# 1. Manual navigation

This chapter introduces the user's manual functions, chapter structure and main contents of S4052 series signal/ spectrum analyzer, as well as the instrument-related documents provided to users.

About the Manual.....	1
Related Documents.....	2

## 1.1. About the manual

This manual introduces the basic functions and operating methods of the S4052 series signal/spectrum analyzers. It describes such contents as product features, basic operations, configuration manual, menu description, remote control, maintenance, technical indicators and testing methods, etc. of the instrument to help users get familiar with and master the operation method and key points of the instrument as soon as possible. To facilitate your skillful use of such instrument, please read carefully and follow this manual in advance for correct operation.

This manual contains the following chapters:

### Overview

This part introduces in general the main performance characteristics, typical application and safety precautions of operation for S4052 series signal/spectrum analyzer . The purpose is to enable users to have a preliminary understanding of the main performance characteristics of the instrument and to guide users to operate the instrument safely.

### Quick Start

This chapter introduces the pre-operation inspection, instrument browsing, basic measurement methods and data management of S4052 series signal/spectrum analyzers. so that users can have a preliminary understanding of the instrument itself and its measurement processes as a preparation for the comprehensive introduction of the measurement operations of the instrument hereinafter. This section contains some contents consistent with the relevant sections in Quick Start.

### Operation Guide

It introduces in detail the operation methods of various measurement functions of the instrument, including configuring the instrument, starting the measurement process and obtaining the measurement results. This part mainly includes two parts: functional operation manual and advanced operation manual. The function operation manual section is intended for users who are not familiar with the use of S4052 series signal/spectrum analyzer. It systematically and detailedly introduces and lists each setting, so that users can understand and master some basic uses of the analyzer, such as setting frequency, span, marker, etc. The advanced operation guide introduces relatively complicated testing processes and advanced operation skills for users who have basic knowledge about using the signal/spectrum analyzer but are not familiar with some special usage, and guides them to implement the measurement processes. For example: multi-signal measurement, distortion measurement, noise measurement, modulation signal measurement, power suite measurement, etc.

### Remote Control

The methods for remote control of the instrument are summarized to make users get familiar with remote control quickly. It is divided into four parts: programmed control fundamentals, introducing concepts related to programmed control, software configuration, programmed control ports, SCPI commands, etc; port configuration methods, introducing the connection methods and software configuration methods for program-controlled ports of S4052 series signal/spectrum analyzers; basic programming methods for VISA interfaces, giving basic programming examples in the form of text description and sample codes to enable users to quickly master the programming methods; I/O function library, introducing the basic concepts of instrument drivers and the basic installation and configuration instructions of IVI-COM/IVI-C drivers.

### Troubleshooting and Repair

## 1. Manual navigation

---

### 1.2 Related Documents

This part includes the introduction of the working principles of the instrument, troubleshooting, error message description and repair methods.

#### Technical Indicators and Testing Methods

This part introduces the product features, main technical indicators and recommended testing methods of S4052 series signal/spectrum analyzer .

#### Annex

It lists the necessary reference information for the S4052 series signal/spectrum analyzer, including: glossary, zoom table of programmed control commands, zoom table of menus, zoom table of error information, etc.

## 1.2 Related Documents

Product documentation for S4052 series signal/spectrum analyzers includes:

- Quick Start
- Online Help
- User's Manual
- Program Control Manual

#### Quick Start

This manual introduces the configuration of the instrument and basic operations for starting measurement with the purpose of: making users quickly understand the characteristics of the instrument, master the basic settings and basic local and program-controlled operations. Main chapters include:

- Manual Navigation
- Get Prepared
- Typical Applications
- Get Help

#### User's Manual

This manual introduces the functions and operation methods of the instrument in detail, including configuration, measurement, program control, and maintenance, etc.. The purpose is to guide users to fully understand the functional characteristics of the product and master common testing methods of the network analyzer. Main chapters include:

- Manual Navigation
- Overview
- Quick Start
- Operation Guide
- Remote Control
- Troubleshooting and Repair
- Technical Indicators and Testing Methods
- Annex

#### Remote Control Manual

This manual introduces such contents as remote programming foundation, SCPI foundation, SCPI commands, programming examples and I/O driver function library in detail. The purpose is to guide users to quickly and comprehensively master the remote control commands and methods of the instrument. Main chapters include:

- Remote Control
- Program Control Commands
- Programming Examples
- Error Description

- Annex

### **Online Help**

The Online Help is integrated into the instrument for providing fast text navigation help to facilitate users to operate the instrument locally and remotely. There are shortcut keys to activate corresponding functions in the instrument shortcut menu area. Main chapters are identical to those of the User's Manual.

## 2.1 Product Overview

## 2 Overview

This chapter introduces the main performance characteristics and main application range of S4052 series signal/spectrum analyzer, and explains how to correctly operate the instrument and electrical safety precautions.

Product Overview.....	4
Safe Operation Manual.....	4

## 2.1 Product Overview

The S4052 series signal/spectrum analyzer can cover the maximum frequency range from 2Hz to 50GHz, with excellent dynamic test range, phase noise, amplitude accuracy and test speed, as well as high sensitivity spectrum analysis, standard power measurement kit, IQ analysis, transient analysis, pulse parameter analysis, audio analysis, analog demodulation analysis, phase noise testing and other test functions, providing you with reliable and high performance test services. The S4052 series signal/spectrum analyzers have good scalability. In particular, their test performance can be improved by flexible configuration of options, or building of the test system or secondary development via various digital and analog signal output interfaces.

## 2.2 Safe Operation Manual

Please read carefully and strictly observe the following precautions!

We will spare no effort to ensure that all production processes meet the latest safety standards and provide users with the highest safety guarantee. The design and testing of our products and the auxiliary equipment used meet relevant safety standards, and a quality assurance system has been established to monitor the product quality and ensure the products to always comply with such standards. In order to keep the equipment in good condition and ensure operation safety, please observe the precautions mentioned in this manual. If you have any questions, please feel free to consult us.

In addition, the correct use of this product is also your responsibility. Please read carefully and observe the safety instructions before starting to use this instrument. This product is suitable for use in industrial and laboratory environments or field measurement. Always use the product correctly according to its restrictions to avoid personal injury or property damage. You will be responsible for problems caused by improper use of the product or noncompliance with the requirements, and we will not be held responsible. **Therefore, please always observe the safety manual to prevent personal injury or property damage caused by dangerous situations.** Please keep the product documentation properly and deliver them to end users.

















Safety marks.....	4
Operation Status and Locations.....	6
Electrical Safety.....	6
Operation Precautions.....	7
Maintenance.....	7
Batteries and Power Modules.....	8
Transportation.....	8
Waster Disposal/Environmental Protection.....	9

## 2.2.1 Safety marks

## 2.2.1.1 Product-related marks

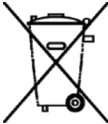
Safety marks on the products are described in Table 2.1:

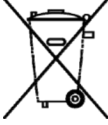
Table 2.1 Products safety marks

Symbol	Meaning	Symbol	Meaning
	Notice, reminding users of information to be paid special attention to.  It reminds users of the operation information or instructions to be paid attention to.		Power ON/OFF
	Notice, handling heavy equipment.		Standby indication
	Danger! Hazard of electric shock.		DC
	Warning! Hot surface.		AC
	Protective conductive end		DC/AC
	Ground		Reinforced insulation protection of the instrument
	Ground terminal		EU mark for batteries and accumulators.  Please refer to Item 1 of "2.2.8 Waste Disposal/Environmental Protection" in this section for specific instructions.
	Notice, please handle classical sensitive devices with care.	 	EU mark for separate collection of electronic devices.  Please refer to Item 2 of "2.2.8 Waste Disposal/Environmental Protection" in this section for specific instructions.
	Warning! Radiation.  Please refer to Item 7 of "2.2.4 Operation Precautions" in this section for specific instructions.		

### 2.2.1.2 Manual-related marks

In order to remind users to operate the instrument safely and pay attention to relevant information, the following safety warning marks are used in the product manual, which are explained as follows:

## 2.2 Safe Operation Manual



Danger mark, personal injury or equipment damage may be caused if not avoided.



Warning mark, personal injury or equipment damage may be caused if not avoided.



Caution mark, slight or medium personal injury or equipment damage may be caused if not avoided.



Notice mark, indicating some important information which will not cause danger.



Tips on information about the instrument and its operation.

### 2.2.2 Operation Status and Locations

Please note before operating the instrument:

- 1) Unless otherwise specified, the S4052 series signal/spectrum analyzer should be operated in an environment that allows for smooth placement and indoor operation of the instrument. The maximum altitude at which instruments are operated and transported shall not exceed 4600 meters. The range of actual supply voltage is  $\pm 10\%$  of the marked voltage, and the range of supply frequency is  $\pm 5\%$  of the marked frequency.
- 2) Unless otherwise specially stated, the instrument has not received any waterproof treatment, do not place the instrument on surfaces with water, vehicles, cabinets, tables and other objects that are not fixed and do not meet the load conditions. Please place the instrument securely and fix it on the surface of a solid object (e.g., an ESD workbench).
- 3) Do not place the instrument in an environment where mist is easily formed, for example, moving the instrument in a environment where cold and heat are in alternation, where water droplets formed on the instrument may cause electric shock and other hazards.
- 4) Do not place the instrument on the surface of a heat-dissipating object (e.g., a radiator). The operating environment temperature shall not exceed the value specified in the description of relevant indicators of the product. Overheating of the product will lead to electric shock, fire and other risks.
- 5) Do not insert any object into the instrument through the opening on the instrument casing, or cover up any notch or opening on the product, which is used for internal ventilation and preventing the instrument from getting overheat.

### 2.2.3 Electrical safety

Precautions for electrical safety of the instrument:

- 1) Before the instrument is powered on, the actual supply voltage should match the supply voltage marked on the instrument.
- 2) According to the power requirements of the real panel of the instrument, a three-core power cord should be adopted while ensuring reliable grounding of the ground wire during operation. Either floating ground or poor grounding may cause damage to the instrument and even cause injury to operators.
- 3) Do not damage the power cord, otherwise electric leakage will be caused, resulting in damage to the instrument and even injury of the operators. If an external power cord or extension socket is used, it should be checked before use to ensure electrical safety.
- 4) If the power supply socket does not provide an on/off switch, to cut the power of the instrument, you can just directly unplug the instrument, and therefore, it should be ensured that the power plug can be inserted or drawn conveniently.

- 5) Do not use damaged power cords. Before connecting the instrument to the power cord, check the integrity and safety of the power cord, and properly place the power cord to avoid the impact due to human factors, such as, too long power cord that may trip the operator.
- 6) Keep the socket clean and tidy, and ensure the plug and the socket in good contact and reliable engagement.
- 7) Neither the socket nor the power cord can be overloaded, otherwise fire or electric shock will be caused.
- 8) Unless otherwise allowed, do not open the housing of the instrument, which may expose internal circuits and devices of the instrument and cause unnecessary damage.
- 9) If the instrument needs to be fixed at the test site, a qualified electrician is required to install the protective earth wire between the test site and the instrument first.
- 10) Take appropriate overload protections to prevent overload voltage (caused by lightning, for instance) from damaging the instrument or causing personal injury.
- 11) Notes: The instrument can discharge poisonous gas or liquid once on fire.

#### 2.2.4 Operation Precautions

- 1) Instrument operators need to have certain professional and technical knowledge, good psychological quality, and certain emergency response capabilities.
- 2) Before moving or transporting the instrument, please refer to the relevant instructions in "2.2.7 Transportation" of this section.
- 3) The inevitable use of substances (e.g. nickel) in the production process of the instrument may cause allergy to personnel. If an operator of the instrument has allergic symptoms (e.g. rash, frequent sneezing, ophthalmia or dyspnea) during the operations, please seek medical care in time to find out the reason and solve the symptoms.
- 4) Please refer to the relevant instructions in "2.2.8 Waste Disposal/Environmental Protection" of this section before disassembling this instrument for disposal.
- 5) RF instruments will generate high electromagnetic radiation, during which period, pregnant women and operators with cardiac pacemakers need special protection. If the radiation level is high, corresponding measures may be taken to remove the radiation sources to prevent personal injury.
- 6) Take antistatic measures such as antistatic table mat, ankle strip and wrist strip to prevent static electricity from damaging the instrument, with antistatic voltage not exceeding 500V.
- 7) Use connectors and cables meeting the test requirement, and check them first before operation.
- 8) When the instrument is measuring, the RF input port can choose DC coupling or AC coupling; when DC coupling is chosen, DC signal input is prohibited, or it will lead to the destruction of the internal parts of the instrument; when AC coupling is chosen, the maximum 50V DC signal can be input.
- 9) Ensure the input signal power at the radio frequency input port of the instrument is lower than the max. safety input level+ 30dBm, so as to prevent the instrument from being burned down.
- 10) It is prohibited to perform hot swapping on interfaces that do not allow hot swapping, such as GPIB and monitor interfaces.
- 11) It is prohibited to remove all joint protectors and matching devices provided with the instrument to avoid joint damage and measurement errors.
- 12) Use the power switch on front panel to shut down normally. It is prohibited to forcefully cut off the power supply; otherwise it may cause operating system abnormalities.
- 13) To ensure the measurement accuracy, the instrument needs to be preheated for 30 minutes before the test. If there is an obvious error in the test above 8GHz, perform the "Automatic preselector adjustment" for calibration.
- 14) Try to keep the instrument connected for optimal measurement results.
- 15) When the measured signal is overloaded, adjust the attenuator or reference level so that the peak value of the measured signal

## 2.2 Safe Operation Manual

is displayed below the top grid of the screen.

- 16) Users are prohibited from deleting factory data.
- 17) Users are prohibited from modifying the settings in BIOS, otherwise it will cause abnormal startup and operation of the instrument.
- 18) The user can delete the file saved by himself/herself rather than the system file.
- 19) When transferring files via the USB port and network interface, make sure the carrier is security and reliable, so as to prevent the instrument from being compromised.
- 20) When GPIB or network ports are used to form a test system, it is necessary to correctly set the addresses of GPIB and network ports.
- 21) In case of any instrument failure, never disassemble it without approval. Just send it back to the factory for maintenance.

### 2.2.5 Maintenance

- 1) Only authorized and specially trained operators are allowed to open the casing of the instrument. Before such operations, it is required to disconnect the power cord to prevent damage to the instrument or even personal injury.
- 2) The repair, replacement and maintenance of the instrument should be performed by dedicated electronic engineers of the manufacturer, and the parts subject to replacement and maintenance should receive safety tests to ensure safe use of the product in the future.

### 2.2.6 Batteries or power modules

Before using batteries and power modules, carefully read the relevant information to avoid explosion, fire and even personal injury.

Precautions for use of batteries include the following:

- 1) Do not damage the battery.
- 2) Do not expose batteries and power modules to heat sources such as open fire; avoid direct sunlight and keep them clean and dry; clean the connection port of the battery or power module with a clean and dry soft cotton cloth.
- 3) Do not short circuit the battery or power module. Do not store multiple batteries or power modules in cartons or drawers because the batteries are likely to cause short circuit due to being in contact with each other or other conductors; Do not remove the original outer packaging of the battery and power module before use.
- 4) Batteries and power modules must not be subjected to mechanical impact.
- 5) If the battery fluid leaks, please do not touch the skin and eyes, otherwise wash it with a large amount of water and get medical treatment in time.
- 6) Please use the manufacturer's original batteries and power modules. Any incorrect replacement and charging of alkaline batteries (such as lithium batteries) is likely to cause an explosion.
- 7) Discarded batteries and power modules shall be recycled and disposed of separately from other wastes. Due to the toxic substances inside the battery, they shall be properly discarded or recycled according to local regulations.

### 2.2.7 Transportation

- 1) If the instrument is heavy, please handle it with care. If necessary, use tools (a crane, for instance) to move the instrument so as to prevent damaging the body.
- 2) The handle of the instrument is suitable for personal handling of the instrument and cannot be fixed on the transportation equipment when during the transportation of the instrument. To prevent property loss and personal injury, please follow the manufacturer's safety regulations on the transportation of the instrument.
- 3) When operating the instrument on the vehicle, the driver should drive carefully to ensure transportation safety, and the manufacturer is not responsible for any emergencies during the transportation. Therefore, please do not use this instrument

during the transportation, and reinforcement and preventive measures should be taken to ensure the transportation safety of the product.

### 2.2.8 Waste disposal/environmental protection

- 1) Do not dispose of devices marked with batteries or accumulators together with unclassified waste; Instead, such devices should be collected separately and disposed of in a suitable collection location or through the customer service center of the manufacturer.
- 2) Do not dispose of waste electronic devices together with unclassified waste; Instead, such devices should be collected separately. The manufacturer has the right and responsibility to help end users dispose of waste products. If necessary, please contact the customer service center of the manufacturer for corresponding disposal so as not to damage the environment.
- 3) During mechanical or thermal processing of the product or its internal components, toxic substances (dust of heavy metals, such as lead, beryllium, and nickel, etc.) may be released. Therefore, specially trained technicians with relevant experience are required to disassemble the product to avoid personal injury.
- 4) During the reprocessing, please refer to the safety operation rules recommended by the manufacturer to dispose of toxic substances or fuel released from the product with specific methods to avoid causing personal injury.

3.1 Get prepared

# 3 Quick Start

This chapter introduces the pre-operation precautions, front/back panel description, basic measurement methods, and data file management of the S4052 series signal/spectrum analyzers. so that users can have a preliminary understanding of the instrument itself and its measurement processes. This section contains some contents consistent with the relevant sections in Quick Start.

Get Prepared.....	1 0
Front and Rear Panels.....	2 3
Basic Measurement Methods.....	3 0
Data Management.....	3 6

## 3.1 Get prepared

Preparation before operation.....	1 0
Operating System Configuration.....	1 9
Routine Maintenance .....	2 2

### 3.1.1 Preparations before operation

The chapter introduces precautions for the S4052 series signal/spectrum analyzers before initial setting and operation.



**Prevent personal injury and damage to the instrument**

Pay attention to the follow to avoid electric shock, fire and personal injury:

Do not open the cabinet arbitrarily;

Do not try to disassemble or refit any part of the instrument not mentioned in the manual. Otherwise, such consequences as reduced electromagnetic shielding property and internal component damage can occur, affecting product reliability. If the product is under warranty, we will no longer provide free maintenance.

Read carefully relevant contents in "2.2 Safety Operation Manual" of the manual as well as the following precautions on safety operation, and pay attention to the requirement on specific operation environment involved in the technical indicators.



**Electrostatic Protection**

Take electrostatic protection measures at workplaces to avoid any damage caused by the instrument. For details, refer to relevant contents in "2.2 Safety Operation Manual" of the user's manual.



**Pay attention to the following when operating the instrument:**

Improper operating or measuring position can damage the instrument or the one connected to it. Pay attention to the following before powering on the instrument:

To ensure that the fan blades and heat radiation holes are unobstructed, the instrument shall be at least 15cm away from the wall, and ensure that all fanvents are unobstructed;

Keep the instrument dry;

Keep the instrument level, and arrange it properly;

The environment temperature meets with the requirement noted in the technical indicators;

Make sure the port input signal amplitude is within the range specified;

Connect the signal output port correctly, without overloading.

## TIPS

### Effect of electromagnetic interference (EMI)

Since EMI can affect the measurement result, pay attention to the following:

Select proper shield cables. For example, to use the double-shielded RF/network connection cable;

Often close any cable connection port that is enabled but temporarily unused;

Pay attention to the electromagnetic compatibility (EMC) level noted in the technical indicators.

U n p a c k i n g .....	1 1
E n v i r o n m e n t a l R e q u i r e m e n t s .....	1 2
P o w e r - o n / o f f .....	1 3
P r o p e r o p e r a t i o n o f c o n n e c t o r s .....	1 6
U s e r i n s p e c t i o n .....	1 8

### 3.1.1.1 Unpacking

#### 1) Visual examination

Step 1. Check the outer packing box and instrument shock-proof package for any damage. If yes, continue to check according to the following steps.

Step 2. Unpack, and check the host and articles provided in the package for any damage;

Step 3. Check carefully the articles mentioned above as per Table 3.1 for any problem;

Step 4: in case of any outer package damage, or damage or problem to the instrument or articles provided in the package, never power the instrument on or start it up! Please contact our customer service center through the service hotline in this manual and we will repair or change it as soon as possible accordingly.

## NOTICE

Handling: since the instrument and packing box are heavy, it shall be handled by two person at the same time, and placed with care.

#### 2) Model confirmation

The accompanying items of S4052 are shown in Table 3.1.

Table 3.1 List of articles provided together with S4052

Name	Quantity	Function
<b>Mainframe</b>		
S4052	1	—
<b>Standard configuration</b>		
3-core power cord	1	—

### 3 Quick Start

#### 3.1 Get prepared

Quick Start	1	—
Certificate of conformity	1	
Packing List	1	—
<b>Options</b>		
To be determined according to the user's selection	—	—

##### 3.1.1.2 Environmental requirements

The operation sites of S4052 series signal/ spectrum analyzer should meet the following environmental requirements:

##### 1) Operating environment

The operating environment should meet the requirements in Table 3.2:

Table 3.2 Environmental requirements of S4052

<b>Working temperature:</b>	0°C~50°C
<b>Relative humidity</b>	When it is > +10°C, the humidity is (5%~95%) RH When it is > +30°C, the humidity is (5%~95%) RH When it is > +40°C, the humidity is (5%~95%) RH
<b>Elevation</b>	0 - 4,600 m

## NOTICE

The above environmental requirements are only applicable to the operating environment factors of the instrument, and are not with the scope of technical specifications.

##### 2) Heat dissipation requirements

In order to ensure that the working environment temperature of the instrument is within the temperature range required by the operating environment, the following heat dissipation space requirements of the instrument shall be met, as shown in Table 3.3:

Table 3.3 Heat dissipation requirements of S4052

<b>Instrument part</b>	<b>Heat dissipation distance</b>
Left and right sides	≥150 mm

##### 3) Electrostatic protection

Static electricity is extremely destructive to electronic components and equipment. Usually we take two anti-static measures: conductive table mat and wrist strap; Conductive floor mat and ankle strap. Using the above two anti-static measurements at the same time can provide good antistatic protection. If using one of them, only the former can provide antistatic protection. 1MΩ earth isolation resistor must be provided for the antistatic components at least for ensuring user safety.

Correctly take the following antistatic measures to techniques to reduce electrostatic damages:

Ensure all instruments are grounded properly, so as to avoid any static electricity;

Let the internal/external conductor of the cable contact the ground shortly before connecting the coaxial cable with the instrument;

Operators must wear anti-static wrist straps or take other antistatic measures before touching the joints, core or conducting any assembly.



#### Voltage range

The above-mentioned anti-static measures cannot be applied when the voltage exceeds 500V.

### 3.1.1.3 Power ON/OFF

#### 1) Precautions before power on

Pay attention to the following when turning on the power of the instrument:

##### a) Confirm power supply parameters

The S4052 series signal/spectrum analyzer supports the power supply of 110V/220V AC. Therefore, please carefully check the power supply requirements of the rear panel of the instrument before using the signal/spectrum analyzer. Table 3.4 shows the external power supply requirement for normal operation of the signal/spectrum analyzer.

Table 3.4 Working power parameter requirements of S4052

Power supply parameter	Applications
Voltage, frequency	110V~220V±10%, 50-60Hz
Power consumption (startup)	<400W (standard configuration)
Power consumption (standby)	< 20W

## TIPS

#### Prevent mutual interference of power supplies

To prevent mutual interference among multiple devices through power supplies, especially spike pulse interference caused by high-power devices which may cause damage to instrument hardware, it is recommended to use a stabilized power supply to supply power to the signal/spectrum analyzer.

#### b) Confirm and connect the power cord

S4052 series signal/spectrum generators adopt three-core power cord interfaces, which conform to national safety standards. Before powering on the signal/spectrum analyzer, it is necessary to confirm **reliable grounding of the ground wire of the** signal/spectrum analyze power line. Either floating ground or poor grounding may cause damage to the analyzer and even cause injury to operators. Using a power cord without protective grounding is strictly prohibited. When the instrument is connected to a suitable power outlet, the power cord connects the housing of the instrument to the ground. The rated voltage value of the power cord should be greater than or equal to 250V, and the rated current should be greater than or equal to 6A.

### 3.1 Get prepared

When connecting the instrument to the power supply:

**Step 1.** Confirm that the working power cord is not damaged;

Step 2. Connect the power plug of the rear panel of the instrument to a well-grounded three-core power socket with the power cord.



#### Grounding

Poor or wrong grounding may cause damage of the instrument or personal injury. Before turning on the power of the signal/spectrum analyzer, make sure that the ground wire is in good contact with the ground wire of the power supply.

Please use a power outlet with grounding protection. Do not use any external cable, power cord or autotransformer without any protective grounding as the protective grounding line. If an auto-transformer is necessary, it is required to connect the common terminal to the protective grounding of the power connector.

### 2) Initial power-on

Precautions for turning on/off the power of the instrument are as follows:

#### a) Connect the power supply

Please confirm the power supply parameters and the power cord before power-on for the first time. For details, please refer to contents on "Precautions before Power-on" in 3.1.1.3 of the User's Manual.

Step 1. Connect the power cord: connect one end of the power cord matched with the signal/spectrum analyzer in the package box or a three-core power cord that meets the requirements to the outlet of the rear panel of the signal/spectrum analyzer (as shown in Figure 2.1), and the other end to the satisfactory AC power supply.

Step 2. Turn on the power switch on the rear panel: as shown in Figure 2.2, observe whether the power switch on the front panel (Figure 2.3) turns on in orange.

**Step 3. Turn on the power switch on the front panel:** do not connect any equipment to the signal/spectrum analyzer before startup as shown in Figure 2.3. If everything is normal, the instrument can be turned on, and then the power switch on the front panel will turn white.



Figure 3.1 Power socket of the rear panel of the S4052 series



Figure 3.2 Power switch of the rear panel of the S4052 series



Figure 3.3 Power switch of the front panel of the S4052 series

**b) Turn on/off the power****i. Start up**

**Step 1.** Turn the power switch on the rear panel to position "I", then the power switch on the front panel will turn orange, and the instrument will be in standby state.

**Step 2.** Turn on the power switch in the upper right corner of the display, and the color of the power switch changes from orange to white;

**Step 3.** The user interface of the front panel of the signal/spectrum analyzer will gradually display relevant information of the starting process of the instrument: to display the manufacturer's name and logo briefly first, and then enter the OS start interface.

**Step 4.** After the operating system is started successfully, the system automatically runs the initialization program of the signal/spectrum analyzer, and displays the main operation interface of the signal/spectrum analyzer.

**The instrument is in the operable status.**

---

**TIPS****10MHz time base and preheating**

When the S4052 series signal/spectrum analyzer is cold started (the instrument is started from a completely closed state), it needs to be warmed up for a period of time in order to keep the instrument's 10MHz time base at the operating temperature. If the instrument is started from standby, there is no need for warm-up. When testing indicators, the instrument should be preheated for 0.5 hours (please refer to the relevant instructions in the technical indicators).

---

**TIPS****Attenuator initialization**

After entering the host program, the sound of setting the attenuator will be generated when setting the attenuator, which does not indicate any error of the signal/spectrum analyzer.

---

**NOTICE****System Startup**

During the BIOS self-test and OS loading, you do not need to intervene, power off, or modify BIOS settings.

**ii. Shutdown**

**Step 1.** Turn off the power switch in the upper right corner of the display. At this time, the instrument enters the shutdown process (the software and hardware may need to go through some processing before the power is turned off). After more than several seconds, the instrument is powered off. At this moment, the power switch changes from white to orange;

### 3.1 Get prepared

Step 2. Push the power button on the rear panel to "O" or disconnect the power supply of the instrument.

**The instrument is turned off.**



#### Power cut of the instrument

When the instrument is in normal operation, it can only be shut down by operating the power button on the front panel. **Do not directly operate the power button of the rear panel or directly disconnect the power connection with the instrument.** Otherwise, the instrument cannot enter the normal shutdown state, which may cause damage to instrument or loss of the current instrument status/measurement data. Please shut down the instrument with the correct method.

#### c) Power cut

In case of emergency, the signal/spectrum analyzer needs to be powered off immediately to avoid personal injury. In this case, just pull up the power cord (from the AC outlet or from the power outlet on the rear panel of the instrument). Therefore, sufficient operating space should be reserved when operating the instrument to facilitate direct shutdown when necessary.

#### 3.1.1.4 Correct use of connectors

Connectors are usually used during various tests via the signal/spectrum analyzer, and the following precautions must be paid attention to in respect of connector operation:

##### 1) Connector check

When conducting connector inspection, anti-static wrist band should be worn. It is recommended to use a magnifier to check the following items:

- Whether the electroplated surface is worn or not and whether there are deep scratches;
- Whether the thread is deformed;
- Whether there are metal particles on the threads and the joint plane of the connector;
- Whether the inner conductor is bent or broken;
- Whether the screw sleeve of the connector rotates improperly.



#### Check the connector to prevent damaging ports of the instrument

Any damaged connector may damage the good connector connected to it even when measuring the connection for the first time. In order to protect each interface of the signal/spectrum analyzer, the connector must be checked before connector operation.

#### 2) Connection method

Before the connection, the connectors should be inspected and cleaned to ensure cleanness and intactness. Anti-static wrist straps should be worn before connection. The correct connection method and steps are as follows:

Step 1: As shown in Figure 3.4, align the axes of the two interconnecting devices to ensure that the pin of the male connector slides concentrically into the socket of the female connector.



Figure 3.4 Connector connection diagram

Step 2: as shown in Figure 3.5, move the two connectors leveled together so that they can be smoothly engaged. Rotate the screw sleeve of the connector (note, not the rotating connector itself) until it is tightened, and there can be no relative rotational movement between the connectors during the connection.

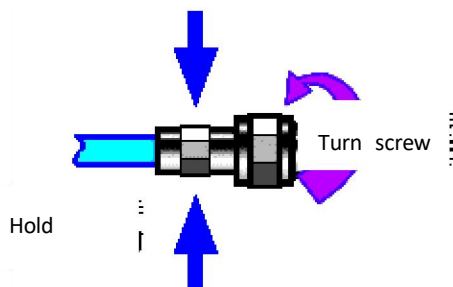

Figure 3.5 Rotary connector diagram

Step 3. As shown in Figure 3.6, tighten the connectors with a torque wrench to complete the connection. Pay attention that the torque wrench should not exceed the initial folding point. Use an auxiliary wrench to prevent the connector from rotating.

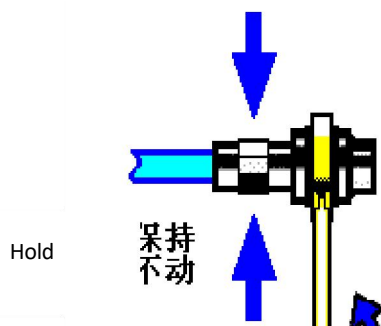

Figure 3.6 Wrench application diagram

### 3) Disconnection method

- Step 1: support the connectors to prevent any connector from being twisted, shaken or bent;
- Step 2: an open-ended wrench can be used to prevent the connector body from rotating;
- Step 3: loosen the screw sleeve of the connector with another wrench;
- Step 4. Rotate the screw sleeve of the connector by hand to complete the disconnection;
- Step 5. Pull the two connectors levelly apart.

### 4) Usage of a torque wrench

The use of a torque wrench is shown in Figure 3.7. The following points should be paid attention to when using it:

- Confirm that the torque of the torque wrench is correct set before use;
- Ensure that the angle between the torque wrench and another wrench (used to support a connector or a cable) is within 90° before applying force;
- Grasp the end of the torque wrench handle gently, and apply force in the direction perpendicular to the handle until reaching

### 3.1 Get prepared

the folding point of the wrench.

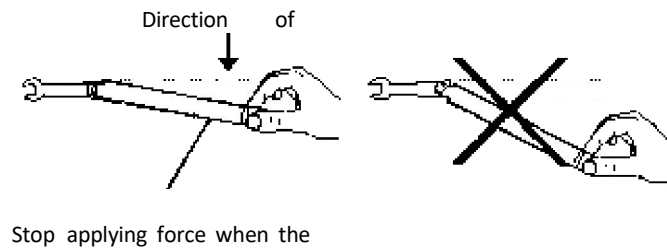

Figure 3.7 Usage of a torque wrench

#### 3.1.1.5 User check

After a S4052 series signal/spectrum analyzer is powered on for the first time, it is necessary to check whether the instrument works normally to ensure subsequent measuring operations.

##### 1) Self-calibration

After using the instrument for the first time or obvious temperature change, self-calibration must be performed to calibrate the instrument according to the calibration signal. Connect the S4052 series signal/spectrum analyzer to the power supply. Check whether the power switch indicator at the upper right corner of the display is orange. If yes, it indicates that the standby power supply is working properly. Touch the front panel power switch gently and observe whether the front panel power indicator light turns white and the back light of the display turns on. You need to wait for about 40 seconds for the display startup until the startup status interface is displayed.

Set the signal/spectrum analyzer as follows:

Step 1. Click [System] in the lower left corner to enter the system menu, click [Calibration], select the item to be calibrated, and click [All] to starting calibration of the whole instrument. When the [All] key turns gray, click [Stop] to stop the calibration.

Step 2. Wait for calibration to end:

When the [Stop] key turns gray the calibration operation is over. If there is no error prompt after the calibration, it indicates that the instrument works normally; If there is an error prompt after the calibration, it indicates that the instrument is not working properly. At this time, Please contact our customer service center through the service hotline in this manual, and we will repair or change it as soon as possible accordingly.

##### 2) Self test

It is not necessary to perform self-test every time the instrument is turned on. Only when it is suspected that the instrument is out of order, do a self-check, and set the instrument as follows:

Step 1. Click [System] in the lower left corner to enter the system menu, click [Self-test], select the item to be self-tested, and click [Start] to start the calibration of the instrument. The [Start] key will turn gray, and then click [Stop] to stop the self-test.

Step 2. Wait till the self-test is completed:

When the [Stop] key turns gray, the self-test operation is over. If there is no error prompt after the self-test, it indicates that the instrument works normally; If there is an error prompt after the self-test, it indicates that the instrument is not working properly. At this time, Please contact our customer service center through the service hotline in this manual, and we will repair or change it as soon as possible

accordingly.

### 3) Function validation

After the self-calibration of the S4052 series signal/spectrum analyzer is completed, set the instrument as follows:

After the self-calibration of the S4052 series signal/spectrum analyzer is completed, set the instrument as follows:

Step 1. Press the [Input/Output] key on the shortcut toolbar to open the Input/Output setting interface, press the [Calibration Port] to open the drop-down menu, select [500MHz] to select the internal 500 MHz calibration signal, and press [Input Port] to select [Calibration]. At this time, the internal calibration signal of the instrument is connected to the RF input port;

Step 2: Press [Frequency] on the shortcut toolbar, select the [Center frequency] key, and enter [5] [0] [0] [MHz] in the input interface to set the center frequency of the analyzer to 500 MHz, and observe the setting result on the instrument screen. If the 500 MHz calibration signal can be observed, it indicates that the channel in the instrument is normal; if it cannot be observed, it indicates that the instrument path is abnormal. In this case, please contact our service consulting center according to the contact information provided in this manual, and we will repair or replace the instrument as soon as possible accordingly.

Step 3. Continue to press [Input/Output] [4.8GHz] to select the internal 4.8GHz calibration signal;

Step 4: Press [Frequency] [Center Frequency], enter [4] [.] [8] [GHz] to set the center frequency of the analyzer to 4.8 GHz, and observe the setting result on the instrument screen. If the 4.8 GHz calibration signal can be observed, it indicates that the channel in the instrument is normal; if it cannot be observed, it indicates that the instrument path is abnormal. In this case, please contact our service consulting center according to the contact information provided in this manual, and we will repair or replace the instrument as soon as possible accordingly.

Step 5. Continue to press [Input/Output] [4.8GHz] to select the internal 4.8GHz calibration signal;

Step 6: Press [Frequency] [Center Frequency], enter [9] [.] [6] [GHz] to set the center frequency of the analyzer to 9.6 GHz, and observe the setting result on the instrument screen. If the 9.6 GHz calibration signal can be observed, it indicates that the channel in the instrument is normal; if it cannot be observed, it indicates that the instrument path is abnormal. In this case, please contact our service consulting center according to the contact information provided in this manual, and we will repair or replace the instrument as soon as possible accordingly.

## 3.1.2 Operating System Configuration

This section introduces the operating system of the S4052 series signal/spectrum analyzers as well as its configuration and maintenance. In order to ensure the normal operation of the software function of the instrument, please refer to the following precautions regarding the signal/spectrum analyzer operating system:

Instrument Software Description.....	19
Operating System Usage.....	20
Operating System Configuration.....	20
Operating System Security and Maintenance.....	22

### 3.1.2.1 Instrument Software Description

The host software of the S4052 series signal/spectrum analyzer runs with the Linux operating system, which has been installed and

### 3.1 Get prepared

configured according to the requirements of the signal/spectrum analyzer.

#### 3.1.2.2 Operating System

The following operations are available with the administrator account:

- Installing third-party software;
- Configuring the network and printers;
- Reading and writing any file on the hard disk;
- Adding and deleting user accounts and passwords;
- Reconfigure operating system settings;
- Running other applications.

---

## NOTICE

### Third party software affects instrument performance

The S4052 series signal/spectrum analyzers adopts an open Linux environment. Installing third-party software may affect the performance of the signal/spectrum analyzers. Only software tested by the manufacturer and compatible with the host software can be run.

#### 3.1.2.3 Operating System Configuration

---

Before shipment of the S4052 series signal/spectrum analyzers, its operating system has been configured to the best state, and any change in the operating system settings may cause the measurement performance of the instrument to decline. Normally, no changes are required to the settings of the operating system.

---

## NOTICE

### Altering system configuration may cause problems

In case of instrument use problem or system crash due to system configuration change, please contact our service consulting center via the service hotline of this manual, we will solve it as soon as possible.

However, in order to facilitate the measurement report generation and system integration, users may change the items listed below as required.

---

Configuring USB Devices.....	2 0
Configure GPIB.....	2 1
Configure the Network.....	2 1
Configure BIOS.....	2 1
External Monitor.....	2 2
Configure Initial State.....	2 2

#### 1) Configure USB devices

Both the front panel and rear panel of the S4052 signal/spectrum analyzer provide USB interfaces for direct connection with USB devices. If the number of ports is insufficient, USB hubs can be externally connected through the USB interface to meet the demand. USB devices that can be connected to the signal/spectrum analyzer include:

**3.1 Get prepared**

USB storages that are directly connected to or removed from the computer to facilitate data updating;

CD-ROM drives for easy installation of firmware programs;

Keyboards and mouses to facilitate data edition and instrument operation;

Printers, to facilitate exporting measurement results.

The operating system supports plug-and-play devices, so it is very convenient to install USB devices. When a device is connected to a USB port, the operating system will automatically search for a matching device driver. If it is not found, the system will prompt you to find the driver directory to complete the installation.

If the USB device is removed from the USB port, the operating system will automatically detect the hardware configuration change and uninstall the relevant driver. The connection and removal of USB devices does not affect the working state of the signal/spectrum analyzer.

The method to connect USB devices is as follows:

#### **a) Connecting storages or CD-ROM drives**

If the storage or CD-ROM drive is successfully installed, the operating system will prompt: "Device is successfully installed and can be used" and automatically display the path name and prompt (e.g., "D:").

#### **b) Connecting the keyboard**

The operating system will automatically detect the USB keyboard connected to the instrument. The default input language is "Chinese (China)-Simplified Chinese-American Keyboard". Keyboard attributes can be configured through "Start > Control Panel > Clock, language and region > Keyboard and language".

#### **c) Connecting the mouse**

The operating system will automatically detect the mouse connected to the instrument, and the mouse attributes can be configured through "Start > Control Panel > Hardware and sound > Devices and printers > Mouses".

#### **d) Connecting the printer**

You can configure the printer using the operating system control panel. Using an external USB mouse and keyboard can make printer configuration easier. If a new printer needs to be installed, only the driver of the printer needs to be installed. The manufacturer of the printer will provide the driver for the printer. The driver can be installed via an external USB CD-ROM device.

### **2) Configure GPIB**

Users may need to modify the GPIB address when using the signal/spectrum analyzer to establish the system. The default GPIB address of the machine is 28. Methods for modification of the GPIB address are described below:

Press [System] [Interface Configuration] to make changes in the input box of GPIB address of this machine.

### **3) Configuring Network**

#### **a) Rename the host**

The host name (computer name) of each S4052 series signal generator/spectrum analyzer has been preset as "saluki-Default-string" before leaving the factory. In order to avoid duplicate names in the network, the user can change the host name by himself when a network is connected to more than one S4052 generators. You can refer to the Help document of Linux for specific steps for changing the host name.

#### **b) Configure IP address, subnet mask, and default gateway**

[System] [Minimize], right-click on the desktop, select Settings, open the system settings menu, select Network in the options bar on the left, open the network settings, click the gear button in the wired settings menu in the network settings interface on the right, open the wired settings menu, click the IPv4 option, select Manual, fill in the IP address, subnet mask and default gateway to be modified below, click Apply after filling in, and return to the network interface settings.

**3.1 Get prepared**

**4) Configure BIOS**

Specific settings for the signal/spectrum analyzer have been made in the BIOS.



**BIOS settings cannot be modified**

The signal/spectrum analyzer has been specifically set in BIOS. Users should not modify the settings in BIOS, otherwise it will cause abnormal startup and operation of the instrument.

**5) External Monitor**

The S4052 series signal/spectrum analyzers support a DP display interface, and an external monitor (or projector) can be connected to the connector of the "Display Port" on the rear panel of the instrument as follows:

- a) Connect the external monitor to the connector on the rear panel of the S4052 series.
- b) It is usually automatically displayed as a dual screen, and if you need other options, you can set them through the graphics card settings in the lower right corner of the system.
- c) Select the instrument to be used for the display:
  - "Display 1" : internal monitor only;
  - "Display 2": external monitor only;
  - "Dual display": internal and external monitors.
- d) If necessary, change the screen resolution you want to use.
- e) Before accepting the setting permanently, test it by pressing "Apply" so that you can easily restore the previous setting if necessary.
- f) If this setting is suitable for use, select "OK".

**6) Configure initial state**

This section describes how to initialize the settings of the S4052 series signal/spectrum analyzer.

**a) Setting the date/time**

The date/time is displayed on the state bar in the lower left corner of the operation interface of the S4052 series signal/spectrum analyzer. The time information is stored synchronously when files are stored. The user can set the date/time in the operating system.

**3.1.2.4 Security and Maintenance of Operating System**

Installing anti-virus software may have some negative effects on the performance of the instrument. It is strongly recommended that users do not use the instrument as a common computer for browsing web pages or transferring files, so as not to be infected with viruses.

Before using various USB mobile storage devices, these mobile devices should first be disinfected with a computer installed with the latest anti-virus software to ensure that they will not become virus carriers.

Once the signal/spectrum analyzer system is infected with virus, it will have a negative impact on its operation and usage. Please contact us for solution.

**3.1.3 Routine Maintenance**

This section introduces the routine maintenance of the S4052 signal/spectrum analyzer.

C l e a n i n g ..... 2 3

T e s t P o r t M a i n t e n a n c e ..... 2 3

### 3.1.3.1 Cleaning method

#### 1) Clean the instrument surface

Please follow the steps below when cleaning the surface of the instrument:

**Step 1:** Shut down the instrument and disconnect the power cord connected to it;

Step 2: wipe the surface gently with dry or slightly wet soft cloth, and do not wipe the inside of the instrument.

Step 3. Do not use chemical cleaners, such as alcohol, acetone or dilutable cleaners.

#### 2) Clean the LCD display

After a period of use, the LCD display needs to be cleaned. Please follow the steps below:

**Step 1:** Shut down the instrument and disconnect the power cord connected to it;

**Step 2:** Dip a piece of clean and soft cotton cloth into the cleaner and then gently wipe the display panel;

**Step 3:** Dry the display panel with a piece of clean and soft cotton cloth;

Step 4. Connect the power cord only after the cleanser is completely dried.

## NOTICE

### Display cleaning

There is an antistatic coating on the surface of the display. Do not use cleaners containing fluoride, acid and alkaline. Do not spray the cleanser directly onto the display panel, otherwise it may penetrate into the instrument and damage the instrument.

### 3.1.3.2 Test Port Maintenance

The S4052 series signal/spectrum analyzer is provided with an RF input port on the front panel. Damage to the connector or the presence of dust inside the connector will affect the test results. Please maintain such kind of connectors as follows:

The connectors should be kept away from dust and kept clean.

To prevent electrostatic discharge (ESD), do not directly contact the joint surface.

Do not use damaged connectors;

Please use an air blower to clean the connectors instead of using tools such as sandpaper to grind the surface of the joint.

## NOTICE

### Port impedance matching

The RF input port on the front panel of the S4052 series signal/spectrum analyzer is a 50Ω connector. A mismatched impedance connector will affect the test result.

## 3.2 Front and Real Panels

This section introduces the composition and functions of the front, rear panels as well as operation interface elements of S4052 series signal/spectrum analyzers.

F r o n t P a n e l .....	2 4
R e a l P a n e l .....	2 7

### 3.2 Front and Rear Panels

#### 3.2.1 Front Panel

This section introduces the composition and functions of the front panels of S4052 series signal/spectrum analyzers. The front panel is shown in Figure 3.8.

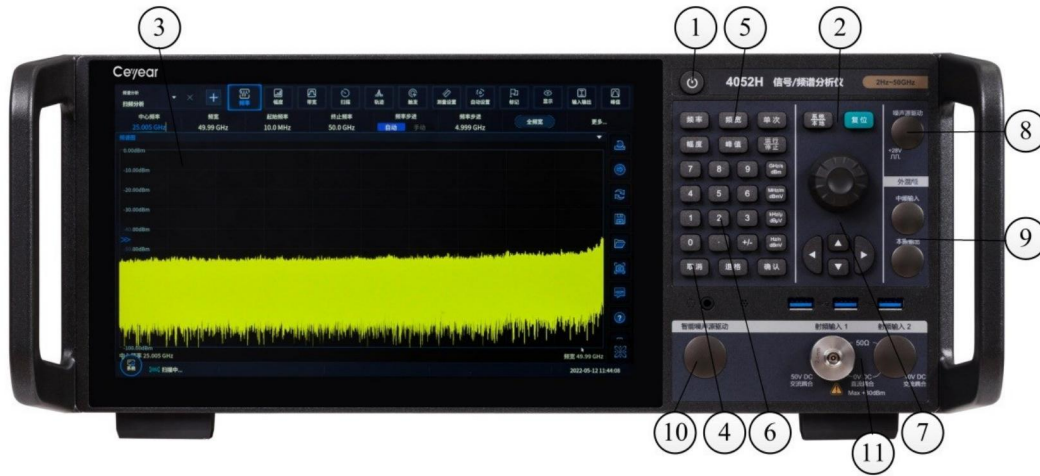

Figure 3.8 Front Panel of S4052 series

- 1. Power button
- 2. System function key area
- 3. Touch Display Area
- 4. Cancel key
- 5. Measurement setting key area
- 6. Number keypad
- 7. Knob, arrow keys
- 8. Noise source driver
- 9. External mixer band input
- 10. Intelligent noise source driver
- 11. RF input

##### 3.2.1.1 Power Supply Button

The power button is located in the upper right corner on the display of the front panel and is used to start and stop the instrument.

##### 3.2.1.2 System Control Key Area

Keys in the function key area are used to set system-level functions, as shown in Table 3.5.

Table 3.5 Description of the system control key area

Key name	Function description
Reset	Restore the instrument to its default state.
System	It provides functions related to system settings: error list, power-on reset, calibration, time and date, input and output, and configuration.

##### 3.2.1.3 Touch Screen Display Zone

This device is equipped with a touch screen, which can complete such operations as instrument parameter setting through the touch screen. All measurement results are displayed on the screen of the front panel. In addition, the display provides state and settings information, allowing you to switch between different measurement tasks. For details, refer to section “3.3.1.1 Display Area Information” of this manual.

##### 3.2.1.4 Cancel Key

It is used to cancel the current operation.

### 3.2.1.5 Measurement Setting Key Area

The measurement settings key area provides the most general measurement settings and functions, as shown in Table 3.6.

Table 3.6 Measurement setting key area description

Key name	Function description
Frequency	It is used to set the center frequency, start and stop frequency, and frequency step of the frequency range currently measured. This button is also used to set frequency offset, auto tuning, and signal trace.
Span	It is used to set the frequency span to analyze or return the previous span.
Amplitude	It is used to set the reference level, attenuator, scale type, scale size, unit, reference level bias, and amplitude correction.
Single	Select single measurement.
Peak	It is used to perform a peak search for the active marker, mark a delta, mark a frequency to assign a center frequency, and mark a level to assign a reference level. If no marker is active, it activates normal marker 1 and performs a peak search on it.
Run/Stop	When it is running, it means continuous measurement (green light), and when it is stopped, it means stopping the current measurement (red light).

### 3.2.1.6 Keyboard



The keyboard is used to enter numeric parameters. It includes the following keys:

#### 1) Digital key

Enter numeric characters in the edit dialog box. For details, refer to "3.3.1.3 Enter Data" in this manual.

### 3.2 Front and Real Panels

#### 2) Decimal point

Insert a decimal point "." at the marker position.

#### 3) Symbols key

Change the symbol of a numeric parameter. When entering alphanumeric parameters, a "-" symbol is inserted at the marker position.

#### 4) Backspace key

If alphanumeric input has begun, this key is used to delete the characters to the left of the marker;

If no input field is currently active, it removes the most recently entered value, that is, to restore the previous value. Therefore, you can switch between two values (for example, frequency step).

#### 5) OK key

It terminates the input of a dimensionless number and sets it to a new value;

For other inputs, this key can replace unit keys such as "Hz/dB".

In the dialog box, press the Default or Focus button.

#### 3.2.1.7 Knob, Arrow Keys

##### 1) Knob function:



When inputting numbers, increase (clockwise) or decrease (clockwise) instrument parameters in specified steps;

In the focus area (such as a list), move the selection bar;

Move markers, limit lines, etc. on the screen;

If a scroll bar has been selected, you can move it vertically;

When pressed, it acts the same as the OK key.

##### 2) Up/Down key function



In the digital edit dialog box, increase or decrease the instrument parameters;

In the list, scroll the list items forward and backward;

In the table, move the selection bar vertically;

In a window or dialog box that has a vertical scroll bar, move the scroll bar.

##### 3) Left and Right key function

In the alphanumeric editing dialog, move the marker;

In the list, scroll the list items forward and backward;

In the table, move the selection bar horizontally;

In a window or dialog box that has a horizontal scroll bar, move the scroll bar.

### 3.2.1.8 Noise Source Drive

Ordinary noise source driver interfaces (noise figure measurement options).

### 3.2.1.9 External Mixing Interface

Available when this option is selected.

LO output interface: 2.4mm connector;

IF input interface: 3.5mm SMA female connector.

### 3.2.1.10 Intelligent Noise Source Drive

Intelligent noise source driver interface (noise figure measurement option).

### 3.2.1.11 RF Input

The device under test can be connected to the RF input port through cable for subsequent analysis.

## NOTICE

Do not overload the input. Refer to the indicator manual for maximum permissible values. For AC coupling, the DC input voltage cannot exceed 50V. For DC coupling, DC voltage cannot be applied to the input. If these conditions are not met, the internal mixer of the instrument will be damaged.

## 3.2.2 Rear Panel Description

This section introduces the composition and functions of the rear panels of S4052 series signal/spectrum analyzers. The rear panel is shown in Figure 3.9.

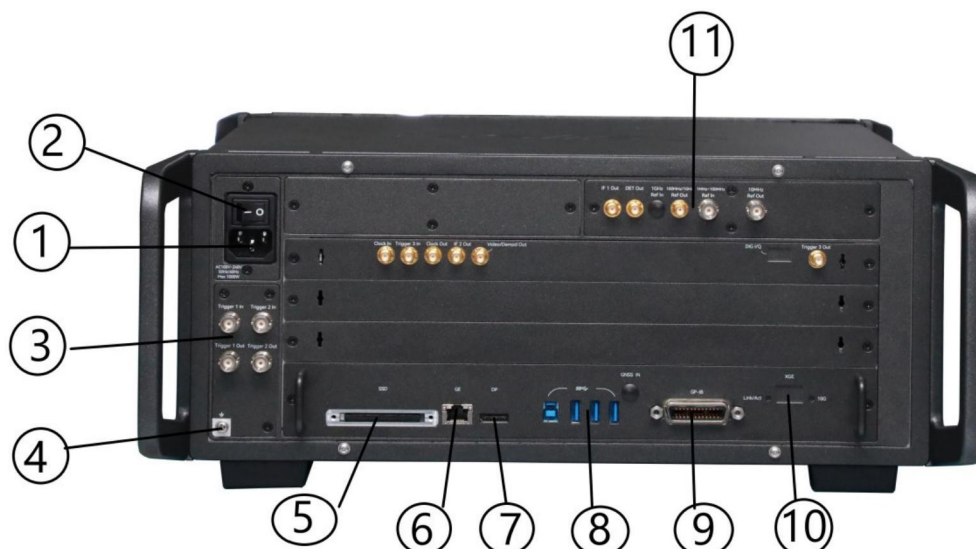

Figure 3.9 Real panel of S4052

- |                                   |                             |                                      |
|-----------------------------------|-----------------------------|--------------------------------------|
| 1. Power input interface          | 5. Electronic hard disk     | 9. GPIB interface                    |
| 2. Power switch                   | 6. Network interface (RJ45) | 10. 10GE network interface           |
| 3. Trigger input/output interface | 7. Display interface        | 11. Reference input/reference output |
| 4. Ground terminal                | 8. USB interface            |                                      |

**3.2 Front and Rear Panels**

**3.2.2.1 Power Input Interface**

Instrument AC power input

**3.2.2.2 Power switch**

Power switch of mains supply of the instrument.

**3.2.2.3 Trigger Input/Output Interface**



Figure 3.10 Trigger Input/Output Connector

Port name	Port description
Trigger input 1	The BNC female connector is used for external trigger signal input on the rear panel with input voltage range [-5V, +5V].
Trigger input 2	The BNC female connector is used for external trigger signal input on the rear panel with input voltage range [-5V, +5V].
Trigger output 1	BNC female connector, TTL level and trigger signal output are used for synchronizing other test equipment. The output signal type is configured by the Input/Output menu.
Trigger output 2	BNC female connector, TTL level and trigger signal output are used for synchronizing other test equipment. The output signal type is configured by the Input/Output menu.

**3.2.2.4 Ground Terminal**

Used for reliable grounding of instruments.

**3.2.2.5 Electronic Hard Disk**

Used for inserting the instrument into the electronic hard disk, and the back cover can be opened to remove or replace the electronic hard disk.

**3.2.2.6 Network Interface**

RJ45 interface, TCP/IP interface, 10/100/1000M adaptive for remote operation of the analyzer.

### 3.2.2.7 Display Interface

DP interface for external display device of the instrument.

### 3.2.2.8 USB Interface



Standard USB3.0 interface, type A. Used to connect peripherals of USB interface type, such as keyboard, mouse, CD-ROM drive, hard disk, etc.

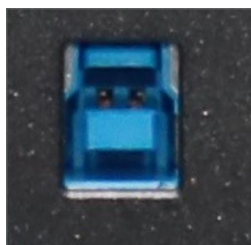

Standard USB TARGET interface, Type B. This device is used for remote control and access as a controlled device.

### 3.2.2.9 GPIB Interface

Standard IEEE488 interface, supporting SCPI language. It is used for remote control.

### 3.2.2.10 10GE Network Interface

Optional, 10 Gigabit optical network interface.

### 3.2.2.11 Reference I/O Interface

Table 3.7 Description of reference input/output

Port name	Port description
10 MHz reference input	BNC female head, used for input of 10MHz reference signals, with the required amplitude greater than 0dBm.
10 MHz reference output	BNC female head, used for output of 10MHz reference signals in the analyzer. The frequency used for other test equipment is locked to the frequency reference of the analyzer.
100 MHz reference input	SMA female head, used for input of 100MHz reference signals, with the required amplitude greater than 0dBm.
100 MHz reference output	SMA female head, used for output of 100MHz reference signals in the analyzer. The frequency used for other test equipment is locked to the frequency reference of the analyzer.

3.3 Basic measurement methods



Figure 3.11 Reference I/O interface on the rear panel

3.3 Basic measurement methods

This section introduces the basic settings and measurement methods of the S4052 signal/spectrum analyzer, including:

Basic Operations.....	3 0
Basic Operation Examples.....	3 3

3.3.1 Basic Operation Instructions

This section provides an overview of how to use the S4052 Series signal/spectrum analyzer, including the types of information displayed in the graphical area, how to use the S4052 series signal/spectrum analyzer through front panel buttons and other interactive operations, and how to use the online help.

3.3.1.1 Display Area Info

The front panel LCD display of the S4052 series signal/spectrum analyzers is used to display the user operation interface, all measurement task statuses, parameter setting and measurement results. The operation interface is shown in the following figure (Figure 3.12), and the detailed description is shown in Table 3.8.

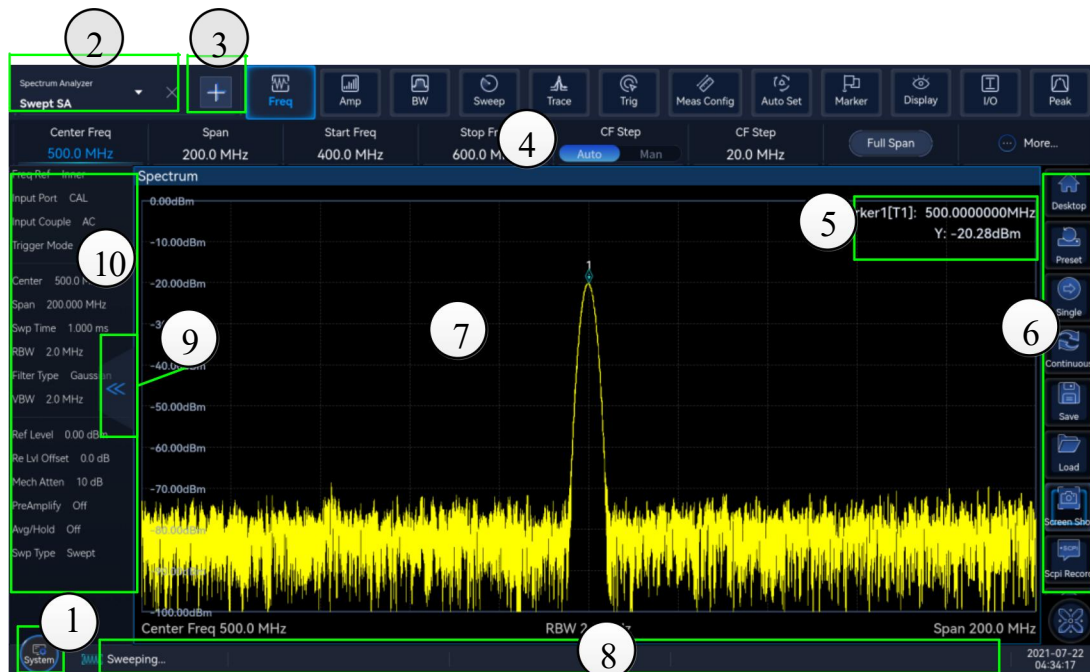
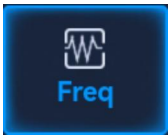
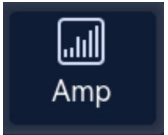
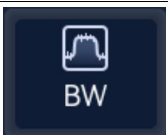
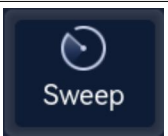
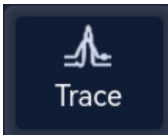
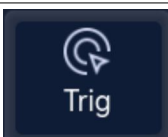



Figure 3.12 S4052 display interface

Table 3.8 Operation interface description

No.	Description
1	System button: Open system settings.
2	Title bar: Display the measurement mode/function in progress. Click the [X] button to delete the current function. Click [v] to open the list of existing functions. You can switch and delete functions.
3	New Function button. New function.
4	Measurement setting key area. Provide the most general measurement settings and functional parameters.
5	Display the active marker information.
6	Shortcut menu area: Contain Reset, Single, Save, Call and other shortcut operations.
7	Display test charts.
8	The instrument and status display, used to display measurement progress and indicating error information.
9	Show/Hide button of the basic parameter display area: Display or hide basic parameter display area.
10	Basic parameter display area: Hidden by default.

Table 3.9 Description of measurement setting key area

Icon	Key name	Function description
	Frequency	Set the center frequency, span, start and stop frequencies, frequency step, frequency offset, automatic tuning, and signal tracking functions for the frequency range currently measured.
	Amplitude	Set the reference level, attenuator, preamplifier, scale type, scale size, unit, reference level bias, and amplitude correction.
	BW	Set resolution bandwidth, video bandwidth, VBW/RBW, span/RBW, filter type, and filter bandwidth.
	Sweep	Set sweep time and number of sweep points, and choose continuous measurement or single measurement.
	Trace	Trace configuration for obtaining and analyzing measurement data.
	Trigger	Select the triggering mode, triggering threshold, triggering delay, and triggering block time.
	Measurement Setting	Set the times of measurement average, average type, limit line, phase noise optimization, preselector, RF gain, and ADC jitter state.

3.3 Basic measurement methods











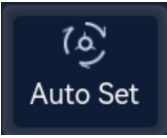

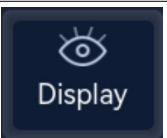

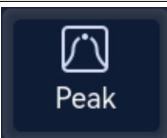
	Auto Set	Enable automatic settings for mechanical attenuator, resolution bandwidth, video bandwidth, VBW/RBW, span/RBW, sweep time and frequency step.
	Marker	Set and position absolute and relative measurement markers (markers and delta markers). Provide additional analytical function for measurement markers:
	Display	Set the display line, language, grid line, state area, and frequency information state.
	In/out	Set frequency reference, coupling mode, input port, calibration port, HF/IF output ON/OFF, and log detection output ON/OFF.
	Peak	It is used to perform a peak search for the active marker, mark a delta, mark a frequency to assign a center frequency, and mark a level to assign a reference level. If no marker is active, it activates normal marker 1 and performs a peak search on it.

Table 3.10 Shortcut menu description

Icon	Button Name	Description
	Desktop	Minimize the signal analyzer software and return to the system desktop.
	Function Reset	It is used for the reset function under the current mode function, which is different from the physical key [Reset], a global reset.
	Single	Select single measurement. Each time a single button is triggered, a measurement is performed, which automatically stops at the end of this measurement.
	Cont	Select continuous measurement.
	Save	Save trace, state and test data.
	Recall	Call trace, state and test data.
	Print Screen	Capture the current screen and save it to the default directory.
	SCPI Record	Enable or disable the SCPI command recording function.

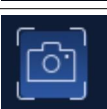
	Help	Open the user's manual or help document.
	Print	Current interface

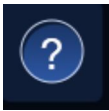
### 3.3.1.2 User Interaction

The instrument provides a user interface without an external keyboard, and the following interaction methods can be used:

Touch screen

Keyboard

Knob

Arrow:

#### 1) Touch screen

The user can realize all the operation and settings of the instrument through the touch screen. Refer to 3.2.1.3 for details

#### 2) Keyboard

Refer to 3.2.1.5 for details

#### 3) Knob

Refer to 3.2.1.6 for details

#### 4) Arrow key

Refer to 3.2.1.6 for details

### 3.3.1.3 Input Data

You can enter data into a dialog box in the following way:

Use the touch screen;

Use the keys provided in the front panel, e.g., keyboard, knobs;

Use the connected external keyboard.

### 3.3.1.4 Gain Help

The S4052 series signal/spectrum analyzer features online help. the online help file can be brought up by pressing  in the shortcut menu area.

## 3.3.2 Basic Operation Examples

This section introduces some common and important basic settings and functions of S4052 series signal/ spectrum analyzers step by step through examples so as to enable users to quickly understand the characteristics of the instrument and master the basic measurement method.

First, pre-operation preparations shall be completed for the signal/spectrum analyzers according to the following steps:

**Step 1.** Power on and startup;

### 3.3 Basic measurement methods

**Step 2.** Initialization after entering the system;

Step 3. Proceed with the following operations when there are no error messages on the main operation interface of the front panel.

#### 3.3.2.1 Measure Sine Signal

The most common measurement task using signal/spectrum analyzer is to determine the level and frequency of the signal. When measuring an unknown signal, you can usually use the [Reset] button to switch the instrument to the preset status and start the measurement. This section describes how to measure a simple sine wave signal using the internal calibration signal of the instrument as input.

## NOTICE

If the signal level is likely to be higher than +30 dBm (=1 W), a power attenuator must be added to the RF input of the signal/spectrum analyzer, otherwise a signal level greater than 30 dBm will damage the RF attenuator or input mixer. At the same time, the total power of all current signals must also be considered.

#### 1) Display the internal 500MHz calibration signal

**Step 1. Reset instrument state:**



Click on the sidebar to restore the instrument to a defined instrument configuration state.

**Step 2. Turn on the internal 500MHz calibration signal:**

Press the [Input/Output] key to pop up the Input/Output Settings soft menu.

Press [Input Port] to open the drop-down menu and select [Cal].

Press [Cal Port] and select [500MHz] to end the input.

At this time, the calibration signal inside the instrument is connected to the RF input port, and the 500MHz calibration signal should be observed on the instrument screen.

#### 2) Optimize signal display

In order to better observe the calibration signal, it is necessary to adjust the main measurement settings.

**Step 1. Set the center frequency as the calibration signal frequency (500MHz):**

Press the [Frep] key.

Press the [Center] key, and enter 500MHz through the digital keys on the instrument panel.

**Step 2. Reduce the span to 20MHz:**

Press the [Frep] key.

Press the [Span] key, and enter 20MHz through the digital keys on the instrument panel.

**Step 3. Set the reference level to -10dBm:**

Press the [Amplitude] key.

Press the [Refer Level] key and input -10dBm through the digital keys on the instrument panel.

At this time, the calibration signal spectrum is displayed in the middle of the track, so that the signal can be observed intuitively and clearly.

### 3.3.2.2 Use Markers

Marker can help you quickly select and read specific track data. It can accurately locate the position of a measurement data in the track, obtain the data information, and indicate its position. Each activation window of S4052 signal/spectrum analyzer can activate a maximum of 12 markers.

The marker function is a more complex measurement process and calculation function based on the marker measurement, which can help you to carry out noise measurement, signal demodulation and high precision frequency measurement and other test tasks.

This section describes the basic concepts and operations of markers and marker functions. The marker function is not available for all measurement modes and measurement functions. The corresponding menu is not displayed in the measurement function without the marker or marker function.

#### 1) Marker type

S4052 series signal/spectrum analyzers have three types of markers:

##### Normal markers

It indicates that the marker is a positional marker. Normal markers can move on the trace point by specifying the horizontal axis coordinate value, and the corresponding trace value is the absolute value of the vertical axis.

##### Difference marker

It indicates that the marker is a numeric tag, and the difference marker indicates the relative value between the selected marker and its reference marker. The difference marker can be moved on track data by specifying the relative value of the horizontal coordinate between its reference marker and the difference marker.

##### Fixed marker

It indicates that the marker is a positional marker. A fixed marker, as the name suggests, is a marker that is fixed in a specified position. The fixed marker can be moved by specifying its horizontal and vertical coordinates, or by the peak search function. After being moves, it will be fixed again. If the normal marker or the delta marker is changed into a fixed marker, the horizontal axis coordinate position and the vertical axis coordinate value corresponding to the marker will be fixed.

#### 2) Active marker

Each marker corresponds to a trace, so the marker can only be activated if there is a trace display in the current active window. If you close the trace display in the current active window, the marker and marking functions of the corresponding trace are also automatically closed. Active markers are indicated by white rhombuss at their corresponding screen locations.

By default, press the [Marker] key in the touch screen test setting key area on the front panel, and the S4052 spectrum analyzer will automatically activate marker 1. The mark type is normal. The trace corresponding to marker 1 is the currently selected trace, and the marker position will be placed as the center of the display area, that is, the center of the X-axis coordinate.

Enter the [Mkr Selection] menu and select another marker by using the softkey. The signal/spectrum analyzer automatically activates this marker and set it to the common marker.

### 3.3.2.3 Peak List Function

Marking the peak list automatically determines the frequency and level in the spectrum.

#### Step 1. Run single sweep:

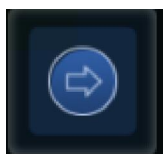

Clicking on the instrument in the sidebar will take a sweep.

#### Step 2. Open the peak list window:

**3.4 Data management**

Press the [Peak] button to open the peak search soft menu.

Press [More] > [Parameter Settings] > [Peak Report Status ON/OFF] to open a new window marking the peak list.

**Step 3 Turn on the peak search function:**

Press [Peak Threshold Status ON/OFF] and set the peak threshold to -60dBm.

To obtain the peak without noise and meet the needs of users, the peak list can be filtered by setting the peak offset and peak threshold parameters in the peak standard menu. For example, set a threshold higher than the noise base.

In the peak list, only one peak greater than -60 dBm is included. Mark the peak list to show the identified peaks that are bigger than the set threshold.

**3.4 Data management**

This section introduces the working state storage/call, measurement result data input/output, and printing/staving screenshots for S4052 series signal/ spectrum analyzer .

Storage/Call Working Status..... 3 6  
 Data Storage/Call..... 3 7  
 Printing/Saving Screenshots..... 3 8

**3.4.1 Storage/calling working status**

Power-on State..... 3 6  
 Function Reset State..... 3 6  
 Storage/Call User Status..... 3 6

**3.4.1.1 Power-on State**

The S4052 series signal/spectrum analyzer uses the state when the user shuts down as the instrument's next power-on state. If no power-on state exists, the factory power-on state is called by default. Usually, when there is an error in the instrument measurement state, the initial state of the instrument during normal operation is restored by resetting the instrument state.

The state of the signal/spectrum analyzer is saved and called as follows:

**Step 1. Select the power-on mode:**

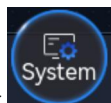

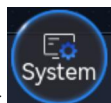
Press the [System] or  button in the main interface of the program to pop up the System Settings dialog box.

In the System Settings dialog box, select [Power On/Reset].

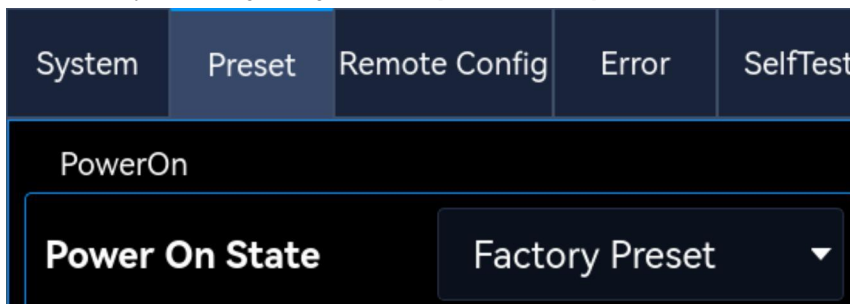

Select [Last State] in the power-on mode.

When a user exits the system, the system automatically saves the current system state.

**Step 2: call status:**

When the system is powered on and the power-on mode is [Last State], the shutdown state saved last time is automatically called.

When the system is powered on and the power-on mode is [Factory Preset], the factory preset state is automatically called.

### 3.4.1.2 Function Reset State

The S4052 series signal/spectrum analyzer uses the last user-saved function state as the initial state for new function. If no user-saved power-on state exists, the factory power-on state is called by default. Usually, when there is an error in the instrument measurement state, the initial state of the instrument during normal operation is restored by resetting the instrument state.

The reset state of the signal/spectrum analyzer is saved and called as follows:

#### Step 1: Save the reset status.

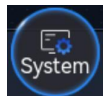

Press the [System] button in the main interface of the program to pop up the System Settings dialog box.

In the System Settings dialog box, select [Power On/Reset].

In the reset mode, select [User] and click [Save User Reset State].

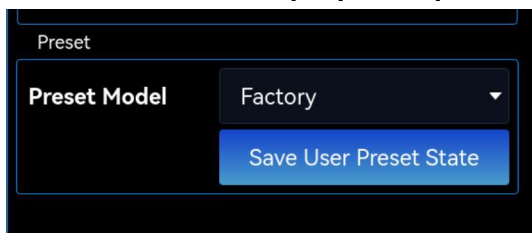

#### Step 2: call resetting status:

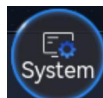

Press the [System] button in the main interface of the program to pop up the System Settings dialog box.

In the System Settings dialog box, select [Power On/Reset].

Select [User] in the reset mode. If you want to reset the factory state, select [Factory].



Press the [Reset] key of the shortcut function to call the reset state for the function.

### 3.4.1.2 Storage/Loading User Status

S4052 series signal/spectrum analyzers provide the function of storing and calling the instrument measurement state (data), which is convenient for users to restore the required measurement state, and observe, evaluate and store the required measurement data again for further analysis.

#### 1) Store instrument state

##### Step 1: Set the file saving type:



Press the shortcut key [Save] or

**3.4 Data management**

Select [State] to change the current save type to "State". +

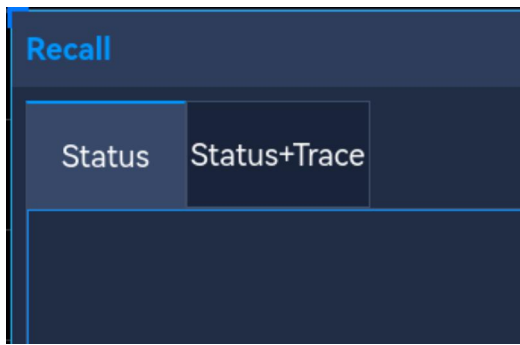

**Step 2: Save the file:**

Press the menu [Save to File].

The "Save File as" dialog box pops up. Select the path and file name to save the file and click "Save".

**2) Call instrument state**

**Step 1. Set the file call type:**



Press the shortcut key [Call] or

Press the soft menu [State] to change the current invoking type to "State".

**Step 2. Call file:**

Press the soft menu [Call].

The file opening dialog box pops up. Select the file you want to call and click Open.

**3.4.2 Data Storage/Call**

The S4052 series signal/spectrum analyzer has the file management function, providing such operations as file save/call, file browsing, and copying, cutting, pasting and deletion of directory (file). Data files can be accessed through front panel keys, mouse or remote control (refer to the Programmed Control Manual of S4052 series signal/spectrum analyzers for details).

**3.4.2.1 Measurement data file type**

The types of data files related to file management are shown in Table 3.10.

Table 3.11 Data file type list

File type	Storage data description
Power-on state file	Store the current measurement state of the instrument for invoking when it is powered on
Reset state file	Store the current measurement state of the instrument for invoking when it is reset
The user saves the state file	Store the measurement state of the current instrument (e.g. center frequency, span, etc.)
User saves trace + state file	Store the trace data of the current trace and the current measurement state

The user saves the image file	Store the bitmap of the current operation screen in the bmp format
The user saves the IQ data file	Store I/Q modulation data
Limit line file	Store the limit line information edited by the user
Amplitude correction file	Store the user-edited amplitude correction information

### 3.4.2.2 File saving/call method

The S4052 series signal/ analyzer provides data file saving/calling function. File saving is to store measurement data in a file according to the agreed format (for example: ASCII, \*. dat); File calling means to open the selected data file and refresh the display information of measurement parameters and list parameters for the convenience of users' observation and evaluation.

According to different information types and management methods, the signal/spectrum analyzer provides four kinds of file saving functions and two kinds of file calling functions. The four files that can be saved are state files, trace (+state) file, images and IQ data files. The types of files that can be called are: state file, trace (+ state) file. The user only needs to enter the corresponding menu to pop up the dialog box, specify the file name to be saved or select the corresponding file to realize the file saving and calling. The details are as follows:

File Saving Method.....	3 9
File Call Method.....	3 9

#### 1 ) File saving method

##### Operation steps:

##### Step 1: Set the file saving type:

Press the shortcut key [Save].

Select the file type in the dialog box.

If you need to save the current measurement state, press [State] to change the current saving type to "State". If you need to save trace data, change the saving type to "Trace (+ State)". In IQ analysis mode, if you want to save IQ data, change the current saving type to "IQ Data". In the "IQ Data" menu, you can set the state of IQ data saving, including: automatic and manual. In the automatic state, the IQ data saved is consistent with the IQ data used for analysis. The IQ data time and IQ data length do not need to be set separately. In the manual mode, you can manually set the time and length of IQ data. When saving IQ data, you need to collect it again.

##### Step 2: Save the file:

Press the [Save] button.

The "Save File as" dialog box pops up. Select the path and file name to save the file and click "Save".

#### 2) File call method

##### Operation steps:

##### Step 1. Set the file call type:

Press the shortcut key [Call].

Select the calling type to select the file type.

3.4 Data management

If the measurement status file needs to be called, press [State] and change the current call type to "State"; if the trace data needs to be called, change the call type to "trace (+state)", then the trace data in the file will be called to the current trace, and change the display mode of the current trace to "Static Display".

Step 2. Call file:

Press soft menu [Call...] to pop up the file opening dialog box, select the file name you want to call, and click Call.

3.4.2.3 File Directory Management

The S4052 series signal/spectrum analyzer does not have a separate file directory management function. To view, assign, cut, paste, and delete files, exit the signal/spectrum analyzer program and perform specific operations on the Linux interface.

3.4.2.4 File Format Description

The signal/spectrum analyzer stores files in direct storage mode. Except for IQ data, all files are in binary format, and file suffixes are determined by file type.

3.4.3 Printing/Saving Screenshots

The S4052 series signal/spectrum analyzers provide such functions as storing snapshots to graphics files (png format) and printing screenshots.

Save Screen (to File).....	40
Print Screen.....	40

3.4.3.1 Saving Screen (to File)

Operation steps:



Step 1. Press the shortcut key [Screenshot] or

Step 2. In the "Save File as" dialog box that pops up, select the path and file name to save the file and click "Save".

3.4.3.2 Print screen

TIPS

Installing Printer Driver

Before printing, supporting printer driver needs to be installed for the S4052 series signal/spectrum analyzer.

Step 1. Open the Printing Settings dialog box:



Press the shortcut key [Print] or to pop up the print setup dialog box.

Step 2. Configure the printer:

Select the corresponding printer; if you need to perform special configuration, you can click attribute to configure the printer in

details. If no printer is configured, the program prints pdf documents by default.

**Step 3. Click OK to finish printing the current screen image.**

## 4 Operation Guide

This chapter introduces the operation methods of different measurement functions and details the measurement steps of the S4052 series signal/spectrum analyzers.

Function Operation Guide .....	4 1
Advanced Operation Guide.....	7 2

### 4.1 Function Operation Guide

This part mainly introduces the related operation methods for the measurement mode, general measurement parameter setting and analysis display of the S4052 series spectrum analyzer.

#### 4.1.1 Introduction to Measurement Mode and Function

This section mainly introduces the main measurement modes of S4052 series signal/ spectrum analyzer and their main uses. In the standard configuration, the signal/spectrum analyzer has two measurement modes: spectrum analysis mode and IQ analysis mode. The user can select the measurement mode through the title bar. For information about measurement mode options, refer to the user's manual of corresponding software option. Each measurement mode of the S4052 series signal/ spectrum analyzer may contain multiple measurement functions. Under the selected measurement mode, you can build the measurement function by pressing the [New] key.

## 4.1 Function Operation Guide

### 4.1.1.1 Spectrum Analyzer Mode

Spectrum analysis mode is a general spectrum analysis and measurement environment, with very flexible spectrum analysis capabilities, including traditional sweep frequency spectrum analysis and FFT spectrum analysis; it features signal spectrum peak search, marking function and a variety of trace detection and trace processing capabilities, so that users can easily find and measure different types of signals.

From the title bar, activate the [Spectrum Analysis] menu to enter the spectrum analysis mode.

The spectrum analysis mode also provides some one-click measurement functions for special types of signals and common measurement applications. The S4052 series signal/spectrum analyzer is pre-configured with the measurement setting parameters for these measurement functions, thus reducing a lot of tedious measurement setting operations for users and facilitating their measurement. The one-click measurement function also integrates a number of measurement algorithms specific to the characteristics of the instrument to optimize the measurement results.

In Spectrum Analysis mode, add the measurement function you want to perform by pressing the “New” function button. The one-click measurement function of S4052 series signal/ spectrum analyzer includes:

- Sweep analysis
- Channel power
- OBW
- Adjacent channel power
- Power statistics
- Burst power
- Harmonic distortion
- Third-order intermodulation
- Spurious emission
- Spectrum emission mask

### 4.1.1.2 IQ Analysis Mode

The IQ analysis mode helps users capture complex time domain data from the RF input port signal, which preserves the vector relationship of the signal's time, frequency, phase and amplitude. By setting the center frequency and analysis bandwidth, the broadband ADC and digital IF processing in the signal/spectrum analyzer can parse the signal into IQ data. These IQ data can be analyzed through the IQ analysis function of this mode, or it can be entered into other external analysis tools for analysis and processing through interfaces such as GPIB, LAN and USB. The IQ analysis tool within the S4052 series signal/spectrum analyzer can perform basic analysis and measurements such as FFT spectrum, time domain and IQ waveform.

In the standard configuration of the S4052 series signal/spectrum analyzer, the IQ analysis of 10MHz bandwidth signals can be analyzed, which can be extended to 40MHz or 200MHz with the option configuration. By pressing the title bar key, activate the [IQ Analysis] menu to enter the IO analysis mode.

## 4.1.2 General Measurement Parameter Setting Guide

This section mainly introduces the concept of basic measurement settings commonly used in spectrum analysis mode and their impact on measurement results, as well as their setting methods. No matter which measurement mode you enter or which measurement task you perform, these concepts and settings methods will help you become familiar with and proficient series signal/ with the S4052 series signal/spectrum analyzer. If you are using another measurement mode, some measurement settings may be slightly different. Please refer to the corresponding measurement mode user's manual.

[Reset and Power-on State Settings](#)

43

[Frequency Span/Horizontal Axis Parameter Setting](#)

45

Bandwidth, Filter and Sweep Setting	47	
Amplitude/Vertical Axis Parameter Setting	53	
Trigger Parameter Setting		53
Measurement Settings and Measurement Control Parameter Settings	58	
Association and Automatic Parameter Settings	62	
I/O Setting		64

#### 4.1.2.1 Reset and Power-on State Settings

The reset state refers to the return of the signal/spectrum analyzer to some known, determined measurement state. There are two types of reset states: factory reset state and user reset state. Through the [Power On/Reset] soft menu in the [System] key, you can set the instrument to return to the factory reset state or the user reset state by pressing the [Reset] key.

Power-on state refers to a known and determined operating state that the signal/spectrum analyzer automatically enters after it is powered on or the signal/spectrum analyzer software program is started from the Linux operating system.

##### 1) Save user resetting state

Step 1. First, set the instrument to the reset working state you want to save;

Step 2. Press the [System] key on the front panel, and press the soft menu [Power On/Reset] to set the reset mode to the user state;

Step 3. Press the soft menu [Save User Reset Status] to save the user reset status.

##### 2) Implement user resetting

Step 1. Press the [System] key on the front panel, press the soft menu [Power On/Reset], and set the reset mode to display the user status.

Step 2. Press [Reset] on the front panel to complete user reset.

### NOTICE

#### Reset

If the user has not saved the user reset state, the signal/spectrum analyzer will automatically return to the factory reset state when the user reset operation is performed.

##### 3) Perform factory reset

Step 1. Press the [System] key on the front panel, press the soft menu [Power On/Reset], and set the reset mode to display the factory state.

Step 2. Press [Reset] on the front panel to complete factory reset.

### NOTICE

If the signal analysis is in programmed control mode, the [Reset] key on the front panel is invalid.

##### 4) Save the user power-on state

Step 1. Set the instrument to the power-on operating state you want to save.

Step 2. Press the [System] key on the front panel, and press the soft menu [Power On/Reset];

#### 4.1 Function Operation Guide

Step 3. Press the soft menu [Save User Power-on State], and the user power-on state is saved.

---



##### **Power on**

If the user has not saved the user power-on state, the signal/spectrum analyzer automatically enters the factory reset state after powering on or starting the signal/spectrum analyzer software program from the Linux operating system.

---

**TIPS****Reset status for different measurement modes and functions**

The S4052 series signal/spectrum analyzer has a variety of measurement modes, and there may be different measurement functions in one measurement mode. Each measurement mode and measurement function of the S4052 series signal/spectrum analyzer has an independent factory reset state and user reset state. The reset operation is performed only for the currently active measurement mode and measurement function.

**4.1.2.2 Frequency and Span/Horizontal Axis Parameter Setting**

The [Freq] key can be used to set the range displayed on the horizontal axis of the current active window of the signal/spectrum analyzer. Under non-zero span (span is greater than zero), the active window of spectrum analysis mode usually displays the signal spectrum trace. The horizontal axis is the frequency axis. The frequency measurement range can be set through the [Freq] key on the front panel. Under zero span (span equals zero), the change trace of signal power over time is displayed, and the horizontal axis is the time axis.

**1) Set parameters of the [Freq] key**

Frequency range (frequency measurement range) refers to the display range of the frequency axis measured by the signal/spectrum analyzer. The frequency range is displayed in the information display area at the bottom of the screen. It is usually displayed in two ways: center frequency value and span value or start frequency value and stop frequency value. The setting parameters corresponding to the [Frequency] key include [Center Frequency], [Span], [Start Frequency], [Stop Frequency], [Frequency Step], [Full Span], [Frequency Offset], [Auto Tuning], and [Signal Tracking].

[Center Freq] is used to set and indicate the frequency value in the middle position of the spectrum measurement display window of the signal/spectrum analyzer;

[Start Freq] is used to set and indicate the frequency value in the far left side position of the spectrum measurement display window of the signal/spectrum analyzer;

[Stop Freq] is used to set and indicate the frequency value in the right position of the spectrum measurement display window of the signal/spectrum analyzer;

[Span] is used to set and indicate the difference between the stop frequency and the start frequency for spectrum measurement of the signal/spectrum analyzer;

[Frequency Step] is used to set and indicate the frequency step amount when the center frequency, start frequency, and stop frequency are changed using the Up/Down key on the front panel;

[Frequency Offset] is used to set and indicate the frequency range correction value in the information display area;

[Full Span] is used to set the frequency measurement range to the maximum frequency range. Note that the center frequency automatically changes to 1/2 of the nominal upper limit frequency of the instrument at this time. This setting is useful for observing signals over the entire range of measured frequencies.

[Zero Span] is used to set the span to 0Hz. In this case, the horizontal axis becomes the time axis, and the time length is automatically the sweep time of the current signal/spectrum analyzer.

[Last Span] is used to set the span to the value set before. This function can help users to quickly switch between full span measurement and detail narrow span measurement.

Press the [Automatic Tuning] menu, the signal/spectrum analyzer will automatically optimize the measurement frequency range and the vertical axis display range according to the signal characteristics of the input port. For the specific setting method and operation guidance of automatic optimization, please refer to section "4.1.2.7 Automatic Settings" of this manual.

[Signal Tracking] is used to track and measure drift signals. The signal can be automatically tuned to the maximum peak

#### 4.1 Function Operation Guide

frequency of the input port signal/center frequency of the spectrum analyzer. For the measurement method of drift signals, please refer to section “4.2.8 Drift Signal Measurement” in this manual.

#### 2) How to set the frequency measurement range

Set the frequency measurement range of the signal/spectrum analyzer through [Freq] and the corresponding soft menu, including the following commonly used methods (for the programming method under the programmed control mode, please refer to the programmed control manual) :

Method 1. Set the frequency measurement range by [Center Freq] and [Span].

**Method 2.** Set the frequency measurement range by [Start Freq] and [Stop Freq].

Method 3. If you want to perform a power measurement in the time domain, set it by [Center Freq] and [Zero Span].

Method 4. If you want to perform a measurement of the entire frequency range, you can set it with [Full Span].

### NOTICE

When the manually-input span is 0Hz, the signal/spectrum analyzer will automatically enter the zero span state and perform time domain power measurement.

**Method 5.** If you want to measure the frequency range set previously, you can use [Forward Span] to quickly set.

Method 6. If you do not know much about the frequency of the RF input signal, you can quickly set it through [Auto-Tune].

The center frequency, start frequency, and stop frequency can be manually set by numeric keys, or adjusted by the Up/Down key and knob on the front panel.

#### 3) How to adjust the frequency measurement range

When measuring in the current frequency range, you can use the following methods to quickly adjust the frequency range:

Method 1. Adjust the center frequency, start frequency, and stop frequency via the Up/Down key and knob on the front panel.

Step 1. Set the frequency step.

Press [Freq] and [Frequency Step], and manually enter the frequency step value you want to set through the numeric keypad on the front panel.

### NOTICE

If the frequency step is automatic, the frequency step corresponding to the Up/Down button on the front panel is 1, 2, 5, and 10 steps. At zero span, the corresponding frequency step of the knob is 1/20 of the current resolution bandwidth. At non-zero span, the corresponding frequency step of the knob is 1/200 of the current span.

Step 2. Press the soft menus of [Center Freq], [Start Freq], or [Stop Freq] that you want to adjust.

Step 3. Press the Up/Down key or knob on the front panel for adjustment.

If you need to adjust the center frequency, press the Up key on the front panel once, and the center frequency will be automatically adjusted to the current center frequency value plus the frequency stepping amount. Press the Down key on the front panel once, and the center frequency will be automatically adjusted to the current center frequency value minus the frequency stepping amount. The adjustment process of the start and stop frequencies is similar to that of the center frequency.

Method 2. Adjust the measured span by pressing the Up/Down key and knob on the front panel. The span step corresponding to the Up/Down key on the front panel of the S4052 series signal/spectrum analyzer is 1--2--5-10, and the step corresponding to the knob is 1/10 of the highest order of magnitude of the current span.

Method 3. If the frequency of the displayed signal is drifting, you can turn on the signal tracking function, and the signal/spectrum analyzer will automatically adjust the center frequency according to the peak value of the signal.

**TIPS**

**The span may change automatically when the center frequency is changed**

The minimum frequency display range of the S4052 series signal/spectrum analyzer is -100MHz, and the maximum display range is related to the highest nominal value of the instrument:

S4052A	4.1GHz;
S4052B	8GHz;
S4052C	13.5GHz;
S4052D	13.5GHz;
S4052E	13.5GHz;
S4052F	13.5GHz;
S4052G	13.5GHz;
S4052H	13.5GHz;

When the center frequency is close to the lower limit of the lowest frequency, if the current span (center frequency +100MHz) is greater than 2 x, the current span is automatically changed to =2 x (center frequency +100MHz). When the center frequency is adjusted to close to the upper limit of the nominal maximum frequency of the signal/spectrum analyzer, and the span is > 2x (displayed range maximum value - center frequency value), the current span will be automatically changed to =2x (displayed range maximum value - center frequency value).

**TIPS**

**Signal tracking rule**

When the signal tracking function is enabled, the signal/spectrum analyzer will automatically take the current marked frequency value as the center, 1/10 of the current measured span as the search span, and set the frequency value corresponding to the searched signal peak value as the center frequency of the next measurement.

Method 4. Use [Marker →] key to adjust the center frequency, start frequency and stop frequency.

For details about how to use the [Marker →] key, refer to section "4.1.3 General Analysis and Display Function Guide in this manual.

**4) How to modify the frequency offset**

If you want the frequency measurement range displayed on the screen to be corrected in the frequency measurement range of the signal/spectrum analyzer, you can press the [Frequency] key first, activate the [Frequency Offset] menu, and set the frequency offset correction through the digital key on the front panel. The frequency offset step setting corresponding to the Up/Down key on the front panel and knob is the same as the frequency step amount.

**4.1.2.3 Bandwidth, Filter, and Sweep Setting**

This section describes the parameter meanings of the [BW] and [Swp] keys, and provides operation guidance. When the signal/spectrum analyzer carries out spectrum measurement, the [BW] key and [Swp] key can be used to set resolution bandwidth, video bandwidth, sweep time, sweep type and other parameters. These parameters are used to determine the acquisition way of spectrum data of the signal/spectrum analyzer and the type of filter. It may be different in other operating modes. For details, refer to related manuals.

## 4.1 Function Operation Guide

### 1) Set parameters of the [BW] key

The settings menu corresponding to the [Bandwidth] key includes [Resolution Bandwidth], [Video Bandwidth], [VBW/RBW], [Span/RBW], [Filter Type], and [Filter Bandwidth].

[RBW] is used to set and indicate the frequency resolution of the signal/spectrum analyzer to perform spectrum measurements. The resolution bandwidth (RBW) parameter determines the minimum frequency interval between two signals. The smaller the resolution bandwidth, the higher the resolution.

For a single frequency signal, the sweep spectrum analysis shows the trace as the shape of the frequency response of the selected IF filter. When the filter bandwidth is changed, the track width displayed by the analyzer is also changed. For two signals of equal amplitude and very close frequency, if a wider filter is selected, the spectrum track of the two signals will be shown as one signal. If a sufficiently narrow filter is used, the two input signals can be distinguished and appear as two separate spectral peaks. So the signal resolution is determined by the IF filter of the analyzer.

When the resolution bandwidth setting is changed, the IF filter inside the analyzer changes simultaneously. Usually, the resolution bandwidth is defined as the filter's 3dB bandwidth, but sometimes the resolution bandwidth is also defined as the filter's 6dB bandwidth. In general, in order to distinguish two signals of equal amplitude, the resolution bandwidth must be less than or equal to the signal frequency interval. If the resolution bandwidth is equal to the signal interval, and the video bandwidth is less than the resolution bandwidth, a 3dB sag will appear between the two signals on the spectrum trace. The smaller the resolution bandwidth, the deeper the sag, and the more obvious the distinction between two adjacent signals.

In order to achieve the desired resolution bandwidth, S4052 series signal/spectrum analyzer adopts IF filter in the sweep frequency spectrum measurement mode and FFT filter in the FFT spectrum measurement mode. FFT filtering can be understood as window function operation before performing FFT spectral operation.

The video bandwidth filter is used for low-pass filtering operation or average operation performed on the spectrum track, which can smooth the displayed spectrum track. In sweep spectrum measurement, [VBW] (VBW) refers to the bandwidth of the low-pass filter executed on the spectrum track. In the FFT spectrum measurement mode, the video bandwidth is the equivalent low-pass filter bandwidth after the average processing of multiple FFT spectrum tracks.

[VBW/RBW] is used to set and indicate the ratio of resolution bandwidth to video bandwidth used in the current spectrum measurement. This parameter can be set automatically or manually. The signal/spectrum analyzer is automatically set to 1, that is, the resolution bandwidth is the same as the video bandwidth. This parameter only affects the video bandwidth Settings. For automatic video bandwidth, VBW value of the signal/spectrum analyzer will be based on the current RBW and [VBW/RBW].

[Span/RBW] is used to set and indicate the ratio of the current span to the resolution bandwidth. This parameter can be set automatically or manually. The signal/spectrum analyzer is automatically set to 106, that is, the resolution bandwidth is approximately equal to 1/106 of the current span. This parameter only affects the resolution bandwidth setting. For automatic resolution bandwidth, the resolution bandwidth of the signal/spectrum analyzer will be determined based on the current span and [RBW].

[Filter Type] is used to set whether the resolution bandwidth of signal/spectrum analyzer is realized by Gaussian filter or flat top filter.

[Filter Bandwidth] is used to set the resolution bandwidth of the signal/spectrum analyzer to 3dB bandwidth, 6dB bandwidth, noise bandwidth, or pulse bandwidth when using Gaussian filters. When this parameter is changed, the resolution bandwidth filter is fixed, and only the bandwidth value of the information display area changes.

### 2) Set parameters of the [Swp] key

The setting parameters corresponding to the [Sweep] key on the front panel include [Sweep Time], [Sweep SGL CONT], [Sweep Type], [Number of Trace Points], [Re-sweep], and [More...].

[Swp Time] is used to set and indicate the time the signal/spectrum analyzer takes to perform a measurement. The parameter information is displayed in the status area on the left of the trace display area. / If the sweep time is automatic, the signal/spectrum analyzer automatically sweeps according to the sweep type and rules set.

[Swp SGLCONT] is used to control whether the user needs to manually start the next measurement or automatically re-measure after

---

**4.1 Function Operation Guide**

the signal/spectrum analyzer completes one measurement. The [SGL] and [CONT] keys on the front panel can also be used to set this parameter.

## TIPS

### Single measurement and single sweep

When "Average Times" ([Measurement Settings] menu) is set to 1, or trace average and trace hold are not enabled, a single sweep and a single measurement are equivalent. Press the [SGL] key once, and the signal/spectrum analyzer stops the measurement after performing a sweep and measurement and enters the idle state.

When the "Average Times" ([Measurement Settings] menu) is set to greater than 1, or any trace is turned on to average or hold, press the [Single] key once, and the signal/spectrum analyzer will perform multiple sweeps or multiple data capture operations, stop measuring when the specified average times is reached, and enter the idle state.

The operation corresponding to the [Single] key on the front panel is to perform a single measurement.

[Trace Points] is used to set the number of trace data that the signal/spectrum analyzer needs to obtain for a measurement.

[Re-Measure] is used to restart the current sweep or measurement. When the trace average/hold function is enabled, press the [Re-Measure] menu, and the signal/spectrum analyzer will reset the current average times and clear the previous holding results.

The [More...] menu pops up a dialog box, including all configurable sweep parameter settings.

### 3) Interaction of bandwidth, filter and sweep time

Bandwidth, filter and sweep time are closely related and interrelated. The values of resolution bandwidth and video bandwidth depend on the filter type selected, and these settings also have an effect on other measurement parameters. Because analog or digital filters are used, the sweep speed is limited by the transient response time of the IF and video filters.

In sweep frequency mode, if  $VBW > RBW$ , the transient time of the video filter has no effect. In this case, the required transient response time is inversely proportional to the square of RBW, with relationship as follows:

$$T_{\text{sweep}} = k \times \text{span} / RBW^2$$

Here,  $T_{\text{sweep}}$  is the minimum sweep time required under a given span and resolution bandwidth, in s;

RBW is resolution bandwidth, in Hz;

Span is expressed in Hz.

K represents the filter constant, depending on the type of filter and the allowable transient response error. By default, the signal/spectrum analyzer uses Gaussian filters.

If  $VBW < RBW$ , the minimum sweep time required is affected by the video filter transient time. Similar to IF filters, decreasing the bandwidth increases the transient time. If analog techniques are used, video filters are usually first-order low-pass or simple RC circuits, so there is a linear relationship between VBW and sweep time. The video bandwidth is reduced by the coefficient n, and the sweep time is extended by n times.

In FFT mode, the sweep time is also restricted by resolution bandwidth and video bandwidth. The sweep time is approximately the sum of the data acquisition time and the time taken to perform the FFT spectrum operation. In the FFT measurement mode, the sweep time cannot be set arbitrarily. the signal/spectrum analyzer provides an approximate value of the sweep time according to the current resolution bandwidth, video bandwidth value and FFT step setting.

### 4) How to set resolution bandwidth parameters

S4052 signal/spectrum analyzers usually automatically set the resolution bandwidth based on the ratio of  $[SPAN/RBW]$  and the current span. S4052 Signal/spectrum analyzer resolution bandwidth has more than 160 levels of settings, with a total of 25 levels in every 10x frequency interval in the range of 1Hz-1mhz, and changes by 10% step from 1Hz to 3MHz, with 4MHz, 5MHz, 6MHz, 8MHz, 10MHz and 20MHz taken above 3MHz. If you want to change the resolution bandwidth, you can do so in the following two ways:

Method 1. Press the [BW] and [SPAN/RBW] to manually change the ratio of span to resolution bandwidth. The resolution bandwidth will be automatically selected and changed according to the ratio.

Method 2. Press [BW] and [RBW] to manually enter the desired resolution bandwidth via the numeric key on the front panel, or set the resolution bandwidth by pressing the Up/Down key and rotating the knob. When the resolution bandwidth value is manually entered through the numeric keys, the signal/spectrum analyzer automatically sets the resolution bandwidth to the first set closest to the input value. When the Up/Down key is used to set the resolution bandwidth, the resolution bandwidth of the signal/spectrum analyzer is changed in the 1--2--3--5--10 steps. When setting the resolution bandwidth with the knob, all resolution bandwidth levels can be selected.

#### 5) How to set video bandwidth parameters

The S4052 signal/spectrum analyzer usually selects the video bandwidth automatically according to the current resolution bandwidth based / on the [VBW/RBW] ratio. Video bandwidth and resolution bandwidth of the S4052 signal/spectrum analyzer / have the same number of sets. If you want to change the video bandwidth, you can do so in the following two ways.

Method 1. Press the [BW] and press [VBW/RBW] to manually change the ratio between RBW and VBW, and the video bandwidth will be automatically selected according to the ratio.

Method 2. Press [BW] and [VBW] to manually enter the desired video bandwidth via the numeric key on the front panel or set the video bandwidth by pressing the Up/Down key and rotating the knob. When the video bandwidth value is manually entered through the numeric keys, the signal/spectrum analyzer automatically sets the video bandwidth to the first set closest to the input value. When the Up/Down key is used to set the video bandwidth, the video bandwidth of the signal/spectrum analyzer is performed in 1--2--3--5--10 steps. When setting the video bandwidth with the knob, all the video bandwidth levels can be selected.

#### 6) Set sweep parameters manually

Manually setting appropriate sweep parameters helps you perform measurement tasks better.

##### Set sweep time manually

When the sweep time is automatic, the S4052 series signal/spectrum analyzer usually automatically selects the fastest sweep time to series signal/ perform the measurement. The maximum measurement error is less than 0.1dB compared to the longer sweep measurements.

Press [Swp] and [Swp Time] to manually set the sweep time by using the numeric key, the Up and Down key on the front panel or the knobs.

## TIPS

#### Setting the sweep time limit

When the sweep type is sweep frequency (and span >0Hz), the signal/spectrum analyzer automatically calculates the minimum sweep time according to the resolution bandwidth, video bandwidth, filter type and other parameters. If the manually set sweep time is less than the minimum sweep time, the signal/spectrum analyzer automatically measures according to the minimum sweep time. If the manually set sweep time is greater than 16000 seconds, the signal/spectrum analyzer automatically performs measurement based on the 16000-second sweep time.

When the sweep type is zero span, the sweep time of the signal/spectrum analyzer is independent of the resolution bandwidth, video bandwidth and filter type. If the manually set sweep time is less than the minimum sweep time (1us), the signal/spectrum analyzer automatically measures according to the minimum sweep time. If the manually set sweep time is greater than 16000 seconds, the signal/spectrum analyzer automatically performs measurement based on the 16000-second sweep time.

If the sweep type is FFT, the sweep time cannot be manually set.

#### How to switch between continuous and single sweep

Continuous sweep refers to the signal/spectrum analyzer automatically performs measurement tasks according to set trigger events.

## 4.1 Function Operation Guide

Continuous sweep is the default state of signal/spectrum analyzer.

Single sweep means that the user's manually controls the signal/spectrum analyzer to perform the measurement task according to the set trigger event. When the trace average function is enabled, the signal/spectrum analyzer will not stop measuring until the specified trace average times is reached. For details, refer to Section "4.1.2.6 [Measurement Settings] Parameter Settings".

The S4052 signal/spectrum analyzer has a variety of methods to help you easily switch between continuous sweep and single sweep. Method 1. Press the [Sweep] key and press the [Sweep Single Continuous] soft menu to switch.

Method 2. Press the [SGL] and [CONT] keys on the front panel to switch.

### Manually configure the sweep type rule

The S4052 signal/spectrum analyzer has two sweep types: sweep frequency and FFT, and there are three sweep type rules, namely, "Automatic", "Dynamic Range Priority" and "Sweep Speed Priority".

The rules for the "Auto" are as follows: When RBW is greater than or equal to 100kHz, set the sweep type to sweep frequency. When RBW is less than 100kHz, the sweep type is selected as FFT.

The rules for the "Dynamic Range Preferential" are as follows: When RBW is greater than or equal to 1kHz, set the sweep type to sweep frequency. When RBW is less than 300kHz, the sweep type is selected as FFT.

The rules for the "Sweep Speed Preferential" mode are as follows: When RBW is greater than or equal to 30kHz, set the sweep type to sweep frequency. When RBW is less than 30kHz, the sweep type is selected as FFT.

Press [Swp] to enter the menu of sweep setting. Then, you can manually set the sweep type rule. In the reset state, the S4052 usually automatically selects the sweep type according to the rule of "Automatic".

### Manually configuring the sweep type

Press [Sweep] key, press [Sweep Type], and the user can manually set the sweep type of the current signal/spectrum analyzer to sweep frequency or FFT.

---

## TIPS

### The parasitic response or residual response of the signal/spectrum analyzer can be determined by changing the sweep type

S4052 signal/spectrum analyzers can use both sweep and FFT for spectrum measurement. When you find a small parasitic response or residual response on the measured data, you can try to determine whether the response is generated by the signal/spectrum analyzer itself or brought in by the input signal by manually changing the sweep type. If the response signal disappears or becomes smaller under different sweep types, it can be considered that the hardware measurement path of the signal/spectrum analyzer causes some signal distortion.

### Configure the FFT width manually

Click the [Sweep] key to activate [More...], and you can set the FFT width in the pop-up dialog box.

Before manually configuring the FFT width, it is important to understand the basic principles and procedures for performing FFT spectrum measurements with the S4052 series signal/spectrum analyzer. When using FFT to measure the signal spectrum in a frequency range, the signal/spectrum analyzer is tuned to the center frequency of the measured frequency range, and then performs FFT spectrum calculations on the acquired time domain data. The maximum frequency range measured in this way is also limited due to the resolution bandwidth, which is called the FFT width. For spectrum measurements in a frequency range beyond the width of the FFT, the signal/spectrum analyzer measures a portion of the frequency range at a time by stepping the center frequency of the instrument's RF receiving circuit, and then splices the measured spectrum together.

The FFT width only comes into play when the signal/spectrum analyzer is set to the FFT sweep type. When the sweep type is automatic, the S4052 signal/spectrum analyzer performs FFT spectrum measurements with a maximum resolution bandwidth of 1MHz. The larger the FFT width, the faster the signal/spectrum analyzer performs FFT spectrum measurements, but at the expense of dynamic range performance.

#### 4.1 Function Operation Guide

For the FFT sweep type, the FFT width setting is equivalent to limiting the maximum step amount of the center frequency per tuning. For example, if you select [ $<10\text{kHz}$ ], the maximum step amount of each tuning center frequency is 10kHz. When the measurement of the same

frequency range is performed, the larger the FFT width, the fewer the number of times the instrument is set to the center frequency, and the faster the measurement speed of the response. To improve the measurement speed, the FFT width can be changed manually.

## 7) Reasonably select filter bandwidth and type

### Manually configure the filter type

Activate [Filter Type] by the [Bandwidth] key, and you can manually select the filter type.

The S4052 signal/spectrum analyzer usually uses a Gaussian filter, that is, a filter with an approximate Gaussian shape to filter the resolution bandwidth. If a flat-top filter is selected, the signal/spectrum analyzer uses an approximate rectangular shape filter to filter the resolution bandwidth. The response time of the flat-top filter of the S4052 signal/spectrum analyzer is about 3 times that of the Gaussian filter, so the sweep speed of the flat-top filter will be slower than that of the Gaussian filter. The flat-top filter has better selectivity than the Gaussian filter, so its ability to distinguish between two unequal amplitude signals is stronger.

### Configure the filter bandwidth manually

Activate [More...] by the [Bandwidth] key, and the user can manually select the filter bandwidth in the pop-up dialog box.

The S4052 series signal/spectrum analyzer has four ways to describe the bandwidth of a Gaussian filter: filter 3dB bandwidth, filter 6dB bandwidth, noise bandwidth, and pulse bandwidth. The noise bandwidth refers to the bandwidth when the rectangular filter is used to pass the noise signal power with the same peak gain. The pulse bandwidth is the bandwidth of the rectangular filter when it is used to pass through the pulse signal power with the same peak gain.

When the electromagnetic interference test is performed, it is suitable to describe the filter bandwidth with 6dB bandwidth or pulse bandwidth; when performing noise-like signal or channel power measurement, it is suitable to describe the filter bandwidth with noise bandwidth.

When the [Filter Bandwidth] parameter is changed, the actual filter bandwidth will not be affected. The signal/spectrum analyzer only uses another description of the filter bandwidth and indicates it in the screen information area. For example, a 3dB filter with a bandwidth of 1kHz is equivalent to a 6dB filter with a bandwidth of 1.41kHz, a filter with an equivalent noise bandwidth of 1.06kHz, and a filter with a pulse width of 1.48kHz.

## NOTICE

When the filter type of S4052 series signal/spectrum analyzer is selected as "flat top", the filter bandwidth cannot be selected, and the [Filter Bandwidth] menu will turn gray.

### 4.1.2.4 Amplitude/Vertical Axis Parameter Setting

This section describes the meaning of the parameters corresponding to the [AMP] key and provides operation guidance. The [AMP] key and the corresponding setting soft menu are used to set the vertical axis reference and display range of the activation window of the signal/spectrum analyzer, which can be used in multiple measurement modes and measurement functions. In the spectrum analysis mode, it is mainly used to set the reference level, attenuator, level display range and amplitude unit of the signal/spectrum analyzer. For other measurement modes or functions, the effect may be slightly different. Please refer to the corresponding manual.

#### 1) Set parameters of [Amplitude] key

The menu corresponding to the [Amplitude] key on the front panel includes [Reference Level], [Attenuator ], [Scale Type Log Linear], [Scale/Div], [Auto Scale], [Vertical Axis Scale Unit ], and [Reference Level Offset].

[Ref Level] refers to the maximum signal value that the measurement hardware of the signal/spectrum analyzer can accept under the condition that the measurement result is distortion-free. If the input level is higher than the maximum value, the signal may be distorted. If

#### 4.1 Function Operation Guide

this happens, the information bar of the S4052 signal/spectrum analyzer displays the prompt "IF overload".

The main role of the [Attenuator ] submenu is to control the gain distribution of the RF receiving hardware of the signal/spectrum analyzer. The parameters that can be set include mechanical attenuator, electronic attenuator, mechanical attenuator step amount, and maximum mixer level. The associated electronic attenuator settings are effective only when the electronic attenuator options are configured correctly.

[Scale Type **Log** Linear] is used to select whether the trace data in the display area is linear or logarithmic. When "Logarithmic" scale is selected, the vertical grid lines are divided logarithmically. The top grid lines correspond to the reference level (when the reference level offset is zero), and the values corresponding to the other vertical grid lines can be set through the amplitude scale. When the "Linear" scale is selected, the vertical grid lines are divided in a linear manner, the top grid lines correspond to the reference level (when the reference level offset is zero), the bottom grid lines correspond to 0V, and the middle grid lines of the vertical axis respectively correspond to 1/10 of the reference level.

[Scale] is used to set the gain value between the grid lines of the vertical axis of the track display area. This parameter is valid only when [Scale Type] is set to logarithmic. When the scale type is linear, the menu automatically grays out and is invalid.

[Automatic Scale] is used to automatically set the amplitude scale and reference value corresponding to the top grid line of the vertical axis for the current measurement data.

[Vertical Scale Unit] is used to change the scale unit displayed on the vertical axis of the trace display area. By default, the vertical axis is measured in dBm when the scale type is set to "Logarithmic", and by default, the vertical axis is measured in V when the scale type is set to "Linear". Whether the scale type is logarithmic or linear, the vertical scale unit can be set to any of dBm, dBmV, dBmA, W, V, A, dBuV or dBuA.

[Reference Level Offset] is used to increase the reference level display by an offset. The reference level represents the absolute amplitude value represented by the top scale of the vertical axis of the trace display area.

#### 2) Set reference level correctly

The reference level represents the absolute amplitude value represented by the top grid of the vertical axis of the trace display area, and is closely related to the maximum signal level that can be received by the RF input port of the signal/spectrum analyzer and the maximum input level that can be received by the internal mixer. If the reference level is not set properly, it will cause serious signal distortion and directly affect the measurement result.

---

### NOTICE

When setting the reference level, consider and understand the total power of all input signals on the RF input port, and set the reference level to be greater than the total power of all input signals.

---

The reference level can be set by activating the [Ref Level] soft menu through the [AMP] key. If you manually set the reference level, the signal/spectrum analyzer usually does not stop the current measurement task, but simply makes a data offset correction on the measurement trace. Only when a change in the reference level causes a change in the associated attenuator will the signal/spectrum analyzer stop the current measurement and restart the measurement.

Generally speaking, the S4052 signal/spectrum analyzer measures the level value of the input signal, and the measurement results show the calibrated and corrected effective value of the unadjusted sinusoidal signal level. By default, the 50Ω input impedance is assumed and the reference level is the converted power value =1mW (0dBm). For details about "Assumed 50 ohm Input Impedance", refer to Section "4.1.2.8 Input/Output Settings" in this manual.

#### 3) Rationally setting attenuator to optimize measurement results

#### **4.1 Function Operation Guide**

The attenuator of S4052 series signal/ spectrum analyzer is at the back end of the RF input port and directly connected to the RF input port. It is mainly used to ensure that the mixer at the back end of the attenuator will not be damaged by the input of high power RF signal.

Therefore, the S4052 series signal/ spectrum analyzer will automatically set the attenuator according to the set reference level by default.

The mixer input level can be calculated by the following formula:

$$\text{Mixer input level} = \text{Signal input level} - \text{Attenuator value}$$



The maximum mixer input level is -10dBm. If the signal level input to the mixer exceeds -10dBm, it may cause incorrect measurements or even damage to the mixer.

---

The measurement sensitivity of the signal/spectrum analyzer is closely related to the attenuator. A large attenuation will increase the inherent noise of the signal/spectrum analyzer, increase the noise base of the trace display area, and reduce the measurement sensitivity of the signal/spectrum analyzer. For high measurement sensitivity, the attenuator is usually set to 0dB. For every 10dB increase in attenuation, the measurement sensitivity will decrease by 10dB and the corresponding average noise level displayed will increase by 10dB. Therefore, in order to improve the signal-to-noise ratio of the measured signal, the attenuation of the attenuator should be reduced. However, the signal/spectrum analyzer can be free of cross modulation or harmonic distortion by setting a large attenuation quantity. In this case, of course, the RF amplifier circuit behind the mixer can re-amplify the signal.

Therefore, the attenuator can be manually set to choose between distortion measurement and high sensitivity measurement, so as to better complete the complex measurement tasks. If your understanding of the attenuator is not deep enough, it is recommended to set the attenuator to automatic correlation mode.

## TIPS

**Benefits of setting attenuator manually**

When performing distortion measurements, such as harmonic distortion or cross modulation distortion, it is very helpful to set the attenuator to a large attenuation value and to determine if the distortion component of the measurement is caused by the signal/spectrum analyzer.

When performing weak signal measurement, setting the attenuator to 0dB is also a very effective method to improve the measurement sensitivity of the signal/spectrum analyzer.

In the S4052 series of signal/spectrum analyzer, two attenuator types are configured, one is a mechanical attenuator and the other is an electronic attenuator. The mechanical attenuator comprises a mechanical attenuator with a 2dB step and a maximum attenuation of 6dB, which also has an AC/DC switching function, and a mechanical attenuator with a 6dB step and a maximum attenuation of 66dB. Together, they form an attenuator assembly that can step by a minimum of 2dB with a maximum attenuation of 72dB. The connection relationship is shown in Figure 4.1.

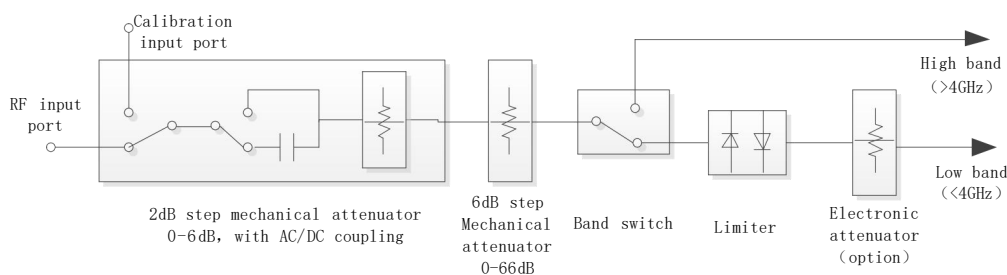

Figure 4.1  
Attenuator  
connection of  
S4052 series  
signal/spectrum  
analyzer  
**Manually  
set the**

**mechanical attenuator**

In general, the mechanical attenuator is automatically set according to the set reference level, and the step of the mechanical attenuator is 2dB.

The signal/spectrum analyzer automatically sets the attenuator according to the following algorithm:

$$\begin{aligned} \text{Attenuator attenuation} = & \text{reference level} + \text{preamplifier gain} + \text{external gain} - \text{reference level offset} \\ & - \text{maximum mixer level} + \text{IF gain} \end{aligned}$$

Whereas, if no preamplifier option is configured, the preamplifier gain is 0dB; the IF gain is a variable gain amplifier at the back end of the mixer circuit, which is not visible to the user and is automatically set by the signal/spectrum analyzer based on the reference level.

In addition, the automatically set attenuator value is greater than or equal to 6dB, the attenuator attenuation calculated by the above algorithm is in accordance with the principle of upward rounding; according to the mechanical attenuator step setting parameters, it automatically selects the closest attenuation value. For example, if the calculated attenuator attenuation is 40.1dB, the attenuator is automatically selected as 50dB (mechanical attenuator step is 10dB) or 42dB (mechanical attenuator step is 2dB).

If you want to set the mechanical attenuator manually, press the [Amplitude] key to change the mechanical attenuator to [Mechanical Attenuator Automatic **Manual**], and modify the amount of mechanical attenuator attenuation by using a number key and Up/Down key on the front panel, or a knob.

You can also manually set the mechanical attenuator step to 2dB or 10dB. When the mechanical attenuator step menu is set to 10dB, that is [Mechanical Attenuator Step 2dB **10dB**]. The attenuation value of the mechanical attenuator can only be set in the range of 0dB-70dB with a minimum step of 10dB. At this time, the minimum step amount corresponding to Up/Down key on the front panel and knob is automatically set to 10dB. When the mechanical attenuator step menu is set to 2dB, that is [Mechanical Attenuator Step 2dB **10dB**]. The

attenuation value of the mechanical attenuator can only be set in the range of 0dB-70dB with a minimum step of 2dB. At this time, the minimum step amount corresponding to Up/Down key on the front panel and knob is automatically set to 2dB.

#### Set the maximum mixer level

The [Maximum Mixer Level] dialog box popped up in the [More...] menu only affects the attenuator automatic setting algorithm. The S4052 series signal/spectrum analyzer has a maximum mixer level of -10dBm by default. Unless you have a very deep understanding of signal/spectrum analyzer measurement principles, do not change the maximum mixer level.

#### 4) How to set the amplitude display range?

##### SetAmplitudeScaleType

The scale type can be selected by pressing the [Amplitude] key to activate the [Scale Type Log Linear] menu. Typically, the signal/spectrum analyzers are set to a logarithmic scale type.

When [Scale Type Log Linear] is selected to be linear, the measurement values are always distributed linearly in the display grid. Linear scales are useful for accurately displaying a small range of signal levels. But if the maximum and minimum values of the signal are displayed on the screen at the same time, it is very difficult to accurately display each value or distinguish between two signal levels that are close to each other. The linear scale type is commonly used for demodulation waveform display of amplitude modulation signals.

When the [Scale Type] is selected to be logarithmic, the smaller measurement display takes up most of the display area of the screen and is therefore very effective for distinguishing low-level signals. Choosing a logarithmic scale type is useful if you want to display measurements with a wide range of signal levels on the same screen. Logarithmic scale types are usually selected for data in logarithmic units (such as dBm or dB).

##### Setting the display range on the vertical axis by amplitude scale and reference level

When the scale type is logarithmic, press the [AMP] key to activate the [Scale] menu. You can set the amplitude value represented by each grid of the vertical axis through the numeric key on the front panel, the Up/Down key or the knobs, in dB. Usually, the signal/spectrum analyzer is set to 10dB.

Activate the [Ref Level] menu by pressing the [AMP] key. The reference level can be changed by numeric key on the front panel, Up/Down key or knobs. The display range of the vertical axis will change. In this case, the measurement value represented by the top grid on the screen is reference level + reference level offset, and the measurement value represented by the bottom grid is reference level + reference level offset -10 x AMP/Scale value.

### TIPS

#### Effect of changing the display range of the vertical axis by changing the reference level

As a result of changing the reference level, the attenuator and IF gain in the RF receiving path of the corresponding signal/spectrum analyzer may also change, and the corresponding measurement performance such as dynamic range or sensitivity will change. If you don't want this to happen, you can set the display range on the vertical axis with the amplitude scale and reference level offset.

#### Set the display range on the vertical axis by amplitude scale and reference level offset

By pressing [More...], the parameter settings dialog box pops up. Changing the reference level offset helps you change the logarithmic amplitude value represented by the top grid of the screen display area.

#### The display range of the vertical axis is set by automatic scale

Press the [Amplitude] key and click the [Automatic Scale] soft menu. The signal/spectrum analyzer will automatically set [Scale/Div] (logarithmic scale type) and reference values according to the maximum and minimum values of the latest measurement data, optimize the display range of the vertical axis, and display all the latest measurement data on the screen. In other measurement modes or functions, the use of the automatic calibration menu corresponding to the activation window is slightly different. For details, please refer to the

## 4.1 Function Operation Guide

corresponding manual or the menu description section of the corresponding function.

### TIPS

#### Auto Scaling

When you click the [Automatic Scale] soft menu once, the signal/spectrum analyzer sets the [Scale/Div] (logarithmic scale type) and reference value only once according to the current measurement data size; even if the measurement data changes later, it will not be reset.

#### 5) Turn on preamplifier (option)

If the signal/spectrum analyzer you purchased is equipped with a preamplifier, press the [Amplitude] key, press [More...] soft menu, and you can see the [Preamplifier ON OFF] menu. By setting this menu, you can enable the preamplifier built into the signal/spectrum analyzer.

By enabling the preamplifier, the signal/spectrum analyzer can obtain a better noise factor and improve the measurement sensitivity, but at the same time, it deteriorates the dynamic range performance of the signal/spectrum analyzer, such as the TOI index.

The S4052 series signal/spectrum analyzer can be configured with a variety of preamplifiers, including the low-band preamplifier (frequency range of 10MHz-4GHz), full-band preamplifier (10MHz- maximum measurement frequency limit), but only one preamplifier can be configured.

The preamplifier gain is automatically taken into account by the signal/spectrum analyzer during sweep. Even if you set the measurement frequency range beyond the operating frequency range of the built-in preamplifier, the signal/spectrum analyzer will show the corrected gain in the measurement result.

#### 4.1.2.5 Setting of Trigger Parameters

In the default setting of the spectrum measurement mode, when the measurement task is started by [Single] and [Continuous], the signal/spectrum analyzer will immediately perform the measurement, which is often referred to as free trigger. However, sometimes the measurement can only be performed when certain measurement conditions are met. For example, perform measurement when the signal level exceeds a certain value or perform measurement according to a certain time period. In this case, you need to use trigger measurement.

Trigger measurement indicates that, when certain measurement conditions are met (also known as trigger events), the measurement is performed or a section of data of the signal of interest is captured. Setting different trigger modes and appropriate trigger parameters can help detect different signal events.

[Trigger] key setting parameters

By pressing [Trigger] key, you can select different trigger modes (also known as trigger sources), and let the signal/spectrum analyzer perform different trigger and measurement tasks. In the spectrum analysis mode, the S4052 series signal/spectrum analyzer has a variety of trigger modes, including free trigger, video trigger, power trigger, external trigger 1, external trigger 2, external trigger 3, burst signal trigger, and timer trigger.

[Video Trigger] refers to the trigger measurement according to the video signal level; [Power Trigger] refers to the trigger measurement based on the power frequency signal of the AC power supply; [External Trigger 1] refers to the trigger measurement based on the trigger input port 1 signal; [External Trigger 2] refers to trigger measurement according to trigger input port 2; [External Trigger 3] refers to the trigger measurement based on the trigger input port 3 signal; [Burst Signal Trigger] refers to the trigger measurement according to the signal power mutation of the RF input port; [Timer Trigger] refers to the trigger measurement according to a pre-defined time period.

In addition to timer trigger and free trigger, other trigger modes have the setting of the trigger slope parameter, and the S4052 series signal/spectrum analyzer can set the trigger slope for these trigger modes. Positive polarity means that a trigger event is generated when the trigger input signal level rises to the trigger level, while negative polarity means that a trigger event is generated when the trigger input signal level falls to the trigger level.

#### **4.1 Function Operation Guide**

In addition to the free trigger, other trigger modes have trigger delay parameter settings, and the S4052 series signal/spectrum analyzer can set the trigger delay state for these trigger modes. Set the trigger delay to the OFF state, and the corresponding menu will display as

[Trigger Delay ON OFF]. The signal/spectrum analyzer will immediately perform measurement after the trigger event occurs. Set the trigger delay to the ON state, and the corresponding menu will display as [Trigger Delay ON OFF]. After the trigger event occurs, the signal/spectrum analyzer will delay for a period of time before performing the measurement. The trigger delay time can be set after activating [Trigger Delay ON OFF] by the a number key and Up/Down key on the front panel, or a knob.

The [Trigger Blocking] can be used to set a time parameter that limits the minimum time interval for a valid trigger event to occur. When trigger block is enabled, the triggered events that occur within the trigger block time are ignored after a trigger event occurs.

### 1) Perform video trigger and measurement

The trigger input signal corresponding to the video trigger is the IF signal envelope displayed on the screen. You can enter the [Trigger Mode] through the [Trigger] key, select [Video Trigger] and press the [Trigger Level] menu to set the trigger level by using a number key and the Up/Down key on the front panel or a knob. In the default state, the video trigger level is -25dBm, and the trigger level display line (red) and trigger level value will be displayed on the screen. "Video Trigger" will be displayed in the corresponding status information indicator bar.

#### TIPS

##### Applicable conditions of video trigger

Video trigger is usually only applicable to time-domain power measurement at zero bandwidth. In non-zero bandwidth (bandwidth>0Hz), setting video trigger may fail to perform correct spectrum measurement. In this case, burst signal trigger can be used instead of video trigger.

### 1) Performing an external trigger and measurement

The trigger input signal corresponding to the external trigger is trigger input 1, trigger input 2, or trigger input 3. The input port can receive signals provided by external devices, and the level range is -5V~+5V. The trigger input signal can be a sinusoidal AC signal or a TTL level signal. When a sinusoidal AC signal is input, the comparator circuit inside the signal/spectrum analyzer compares it with the set trigger level value and converts it into a TTL level signal.

The external trigger level can be set by pressing the [Trigger] key, pressing the [Trigger Mode] menu, selecting [External Trigger 1], [External Trigger 2] or [External Trigger 3], pressing the soft menu [Trigger Level], and using a number key, and Up/Down key on the front panel or a knob.

#### TIPS

If the signal is in the external trigger and measurement state and the signal/spectrum analyzer cannot perform the measurement correctly, please carefully check that the instrument is properly connected to the external device and ensure that the correct external trigger input signal is provided.

### 2) Perform power trigger measurement

The trigger input signal corresponding to the power trigger is the power frequency signal of the AC power supply provided to the signal/spectrum analyzer, which is automatically extracted by the internal circuit of the signal/spectrum analyzer and converted into the trigger input signal. You can press the [Trigger] key to enter the [Trigger Mode] menu and select [Power Trigger] to set the trigger slope and trigger delay parameters. The trigger level is invalid when the power supply is triggered, and the corresponding trigger level menu is not enabled.

#### 4.1 Function Operation Guide

### 3) Perform burst signal trigger measurement

The trigger input signal corresponding to the burst signal trigger is the IF signal envelope output by the signal/spectrum analyzer in the second IF frequency, which are also called IF power trigger in some signal/spectrum analyzers. At this time, the IF bandwidth is also called trigger bandwidth, and when the burst signal of the S4052 series signal/spectrum analyzer is triggered, the trigger bandwidth is about 200MHz. In non-zero span measurement, the second IF signal approximately reflects the start frequency signal of the instrument measurement. In zero span measurement, the second IF signal reflects the signal of the measuring center frequency of the instrument. Since the signal/spectrum analyzer has an IF bandwidth of 200MHz, noise limits the setting range of trigger levels. For details, please refer to the data manual of the S4052 signal/spectrum analyzer.

The trigger level can be set by pressing [Trigger] key, pressing [Trigger Mode] menu, selecting [Burst Signal Trigger], pressing [Trigger Level] soft menu, using a number key and Up/Down key on the front panel, or a knob.

---

**TIPS**

The trigger level setting of the burst signal of the S4052 series signal/spectrum analyzer does not take into account the effect of amplitude correction and reference level offset, so the trigger level you set may have a large gap with the signal level displayed by the measurement, which can be eliminated by turning off the amplitude correction and modifying the reference level offset.

---

**NOTICE**

When the start frequency of non-zero span measurement or the center frequency of zero span measurement is close to 0Hz and less than 120MHz, the LO feedthrough will cause the burst signal trigger performance to decline or trigger failure.

---

**4) Perform timer trigger measurement**

The trigger input signal corresponding to the timer trigger is the signal output by the periodic timer inside the signal/spectrum analyzer.

In general, the measurement of burst RF signals is very complicated and difficult. Although the use of burst signal trigger can help you to perform some conventional burst RF signal measurement work, but there are many restrictions; sometimes the measurement can not be performed, such as the burst RF signal to be measured is too small to form an effective trigger signal, or the frequency is less than 100MHz. If you already know the period of the burst signal, you can use the timer trigger to measure. Sometimes, the period generated by the burst RF signal is slowly drifting, or the internal time reference of the signal/spectrum analyzer is different from the time reference of the device under test. The S4052 series signal/spectrum analyzer can also be used for measurement by adjusting the timer trigger offset and enabling the timer trigger synchronization function.

To help you better understand and use the timer trigger function, Figure 4.2 shows the timing diagram of the timer trigger measurement. The synchronization signal triggered by the timer in the figure is selected as the signal of the trigger input port 1 on the front panel. The waveform at the top of the figure is the signal waveform of trigger input port 1 on the front panel. Its rising edge prompts the timer to perform synchronization processing, and then the timer generates timing pulses according to the time reference provided by the signal/spectrum analyzer. After blocking the timing synchronization source, the timer synchronizes according to the trigger input rising edge. Because the internal time base of the signal/spectrum analyzer is different from the time base of the measured signal, the timer output will drift during blocking of the timing synchronization source. The timing offset determines when the actual trigger event occurs. After the timing trigger event occurs, if the trigger delay is on, the signal/spectrum analyzer waits for the trigger delay time to start the measurement.

4.1 Function Operation Guide

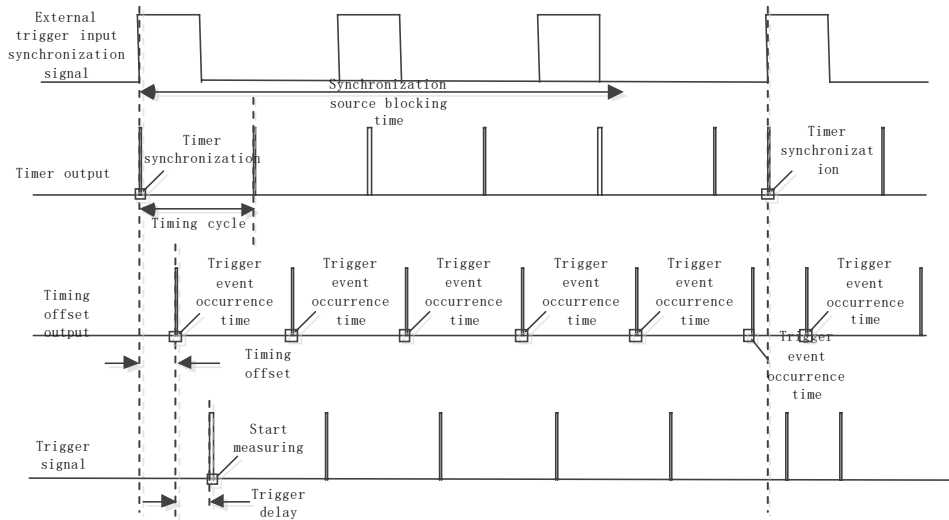

Figure 4.2 Timing relationship between timer trigger and timing synchronization

Press [Trigger], press the [Trigger Mode] menu, select [Timer Trigger], any you can set timing trigger parameters such as [Synchronization Source Selection], [Timing Period], [Timing Offset], [Timing Source Block], and [Trigger Delay] using a digital key, and Up/Down key on the front panel, or a knob.

The synchronization source can be selected as external trigger 1, external trigger 2, external trigger 3, or burst signal trigger. In the [Synchronization Source Selection] menu, you can also set the trigger level and synchronization source slop by [External Trigger 1], [External Trigger 2], [External Trigger 3], and [Burst Signal Trigger]. The slope of the synchronization source is set to "positive", that is, [Sync Source Slope Positive Negative], which means that the timer output is synchronized with the rising edge of the synchronization source signal. The slope of the synchronization source is set to "negative", that is, [Sync Source Slope Positive Negative], which means that the timer output is synchronized with the falling edge of the synchronization source signal. When setting the trigger level of the synchronization source, the trigger level in the corresponding trigger mode menu changes at the same time.

**NOTICE**

When setting timer trigger parameters, the signal/spectrum analyzer first resets the internal timer, sets the timing parameters (the default timing offset is 0), and then starts the timer. When you modify [Timing Offset] through the menu, the signal/spectrum analyzer will not reset or restart the timer, but only modify the occurrence time of the trigger event.

4.1.2.6 [Measurement Settings] and [Measurement Control] Parameter Settings

This section describes the parameters corresponding to the [Measurement Settings] key. Under different measurement modes and functions, the parameters corresponding to the [Measurement Settings] key vary greatly.

1) Description of the [Measurement Settings] key parameter

In the spectrum analysis mode, the parameters corresponding to the [Measurement Settings] key on the front panel include [Average Times], [Average Type], [Limit Line], [Phase Noise Optimization Rule], and [ADC Jitter].

**Set Trace Avgs**

Press [Measurement Settings] to set the number and type of trace average. To start trace average, press [Trace], select the trace to be averaged, and activate the [Average] menu.

[Average Times] is used to control the Average Times when trace average (the [Trace] key) is activated.

[Average Type] is used to control the averaging processing algorithm for trace data, including Video Average, Voltage Average or Power Average.

Video average (also known as log power average) means average of signal levels in logarithmic units of measurement.

Power average (also known as effective value average) refers to the conversion of all measurement results to power values, and after the average is completed, the average result is converted to the measurement value required by the display scale.

Voltage average refers to the conversion of all measurement results into voltage values, and after averaging is completed, the average result is converted to the measurement value required by the display scale.

For more information on trace average, please refer to the corresponding menu description.

If the average type is set to automatic, the signal/spectrum analyzer will automatically select the average type based on the detection type, marker function, amplitude scale, etc., of the corresponding trace. The rules for automatic selection of the average type are as follows: if the trace detection (refer to the relevant content in Section 4.1.3 for detection) is the average power average, the average type is selected to be power average; if the trace detection (refer to Section 4.1.3 for the detection) is voltage average, the average type is selected to be voltage average; if the noise marker, bandwidth power or bandwidth density of the marker function (refer to 4.1.3 for the marker function) is enabled, the average type is selected to be power average; if the amplitude scale is selected to be linear scale (for details about the amplitude scale, refer to 4.1.2.4), the average type is set to voltage average; otherwise, the average type is set to video average.

---

TIPS

**Average operation in S4052 signal/spectrum analyzer**

Track averaging is to average the signal levels of multiple tracks generated by multiple sweeps.

Video average detection, power average detection and voltage average detection serve for the average operation of the time period or frequency interval data of the response of the data at a certain point of a trace.

Noise marker is the average calculation of data at multiple measurement points of the same track, which is used to reduce amplitude fluctuation.

Video filtering can also be considered as similar averaging operations on the same measured track.

---

---

NOTICE

The average operation on the logarithmic power data will produce completely different measurement results than the log conversion on the data after the average operation.

---

**Limit line measurement**

The limit line measurement function can help you quickly perform certain specified compliance measurements. By pressing the [Measurement Settings] key, press [More...] Menu, select the [Limit Line] tab in the pop-up parameter setting dialog box, you can edit the limit line and start the limit line measurement.

**Control ADC jitter**

After entering the [ADC Dither] menu corresponding to the [Measurement Settings] key, you can manually turn on and off the ADC Dither circuit of the signal/spectrum analyzer. The ADC jitter function can help improve the linearity of low-level signal measurement, but this comes at the expense of some measurement signal-to-noise ratio performance.

With ADC jitter enabled, the signal/spectrum analyzer can provide better measurement linearity, which improves scale fidelity, especially when measuring small signals. Disabling ADC jitter results in a lower noise base.

By default, ADC jitter is in the automatic state, and the signal/spectrum analyzer automatically controls the ON/OFF of ADC jitter according to different measurement Settings.

**4.1.2.7 Association and Automatic Parameter Settings**

The S4052 series signal/spectrum analyzer has a number of measurement parameters that can be automatically set according to the current measurement status, which helps you to make measurements more convenient.

If you want to quickly locate the frequency and amplitude value of the measured signal, press the [Automatic Settings] key and activate the [Automatic All] menu, and you can automatically set the frequency and amplitude of the measured signal to the most suitable state for measurement. [Auto Tune] is used to automatically tune the frequency of the signal, [Auto Level] is used to automatically set the amplitude of the signal, and [Auto Sweep Time] is used to automatically set the sweep time of the current measurement.

---

NOTICE



After the automatic parameter settings in the menu are modified, the parameters of the corresponding other menus are also modified accordingly.

#### 4.1.2.8 I/O Setting

The input/output settings are valid for all measurement modes and functions of the signal/spectrum analyzer. The [Input/Output] key is used to control the input/output parameters of the signal/spectrum analyzer. Usually, when changing input/output parameters, it may involve the input/output interfaces of the front and rear panels of the signal/spectrum analyzer, which are generally unchanged, so most input/output parameter settings will not change when the reset operation is performed.

### NOTICE

Although input/output parameters are global parameters relative to measurement modes and measurement functions of the signal/spectrum analyzer, changing these parameters affects all measurement modes and measurement functions, but some parameters are not valid for some measurement modes or measurement functions.

#### 1) Set frequency reference

By pressing the [Input/Output] key, you can select the frequency reference signal used by the signal/spectrum analyzer from the internal, 10MHz, 100MHz or any frequency reference signal through the [Frequency Reference] menu.

### NOTICE

When the frequency reference is set to internal, the reference output of the rear panel is the 10MHz signal inside the instrument; when the frequency reference is set to 10MHz, 100MHz and any other value, the reference output of the rear panel is the reference input signal of the rear panel.

When the signal/spectrum analyzer sets the frequency reference to internal, the signal/spectrum analyzer still uses the internal 10MHz reference signal even if the external reference input port on the rear panel is connected to an external device.

When the frequency reference is set to 10MHz, 100MHz, or any other value, the signal/spectrum analyzer will use the reference signal provided by the external reference input port on the rear panel, and the information display area on the screen will display "Reference: 10MHz" or other corresponding information. When perceiving that the external reference input signal is incorrect, for example, there is no reference input, and the signal power does not reach the required power range, "Reference Loop Loss of Lock" is displayed in the error message area. Once the external reference meets the requirements specified by the signal/spectrum analyzer, the error message is cleared.

#### 2) Set Input Port

##### Enter port selection settings

Press the [Input/Output] key to select from the [Input Port RF Calibration] menu whether the signal/spectrum analyzer measures the RF signal input from the front panel or the internal calibration signal.

The RF input status is displayed in the information display area on the front panel. If the calibration signal is selected, "Input Port Calibration" is displayed; If you select the RF input signal of the front or rear panel, "Input Port RF" is displayed.

##### Calibration port selection settings

If the RF input is selected to be calibration, i.e. [Input Port RF Calibration], you can select any of the five calibration signals inside the instrument through the [Calibration Port]. The five calibration signals are 500MHz sine signal, 4.8GHz sine signal, 9.6GHz sine signal, comb

## 4.1 Function Operation Guide

wave signal and broadband calibration signal.

The internal calibration signals of the signal/spectrum analyzer are mainly used for instrument calibration. When performing calibration operations (by pressing the [System] key, the parameter setting dialog box pops up for entering the [Calibration] label, and you can calibrate the instrument), the instrument will automatically select these calibration signals without user intervention.

Setting the RF input to calibration can help you learn to use the instrument or determine if the instrument is faulty.

### Coupling type settings

Press the [Input/Output] key to switch the coupling mode of the input port of the signal/spectrum analyzer through the [Coupling Mode AC DC] menu. AC indicates AC coupling and DC indicates DC coupling. The signal/spectrum analyzer defaults to DC coupling.

If alternating current (AC) coupling is selected, the RF input back end is inserted with a DC-blocking capacitor to prevent DC signals from entering the signal/spectrum analyzer's internal circuit, thereby effectively protecting the signal/spectrum analyzer from being damaged by DC voltage present at the RF input port. However, AC coupling can limit the frequency measurement range of the signal/spectrum analyzer, mainly affecting the measurement of low-end frequency signals, such as input signals less than 10MHz.

The measurement performance of the S4052 series signal/spectrum analyzer for signals smaller than 10MHz is guaranteed in a DC-coupling mode.

If the coupling mode is direct current (DC) coupling, ensure that the DC voltage of the RF input port is between 0V and 200mV.

Regardless of DC coupling or AC coupling, the signal power of the RF input port cannot exceed +30dBm (1W).

## 4.1.3 General Analysis and Display Function Guide

This section mainly introduces the operation series signal/ instructions of S4052 signal/spectrum analyzer in spectrum analysis mode, using tracks and markers for general analysis and display. No matter what kind of measurement mode you use or what measurement tasks you are performing, these operations will help you become familiar with and proficient in using the S4052 signal/spectrum analyzer. If you are using another measurement mode, the measurement analysis method may be different; please refer to the corresponding measurement mode instruction.

Trace Detection and Trace Operation.....	6 6
Use Marker.....	6 6

### 4.1.3.1 Trace Detection and Trace Operation

A trace is a set of data sampling points. Each data point (x, y) has an x value and a y value. The x value usually represents the frequency or time, and the y value usually represents the amplitude. Each data point is also called a track point. In any trace, the first data point is called trace 0 and the last data point is called trace (sweep points -1), and the number of trace points is also called sweep points. For the spectrum trace, a trace point usually corresponds to a frequency interval, sometimes called a Bucket, and the measured value Y represents the measured data corresponding to a Bucket. The menu corresponding to the [Trace] key on the front panel can help you configure the measurement trace to complete trace operation.

Each track can be considered an analysis of the measured data. The S4052 series signal/spectrum analyzer can display up to 6 traces in each trace window. Track configuration determines how measurement data is analyzed and displayed. This section describes how to configure and calculate traces.

#### 1) Concept of trace detection

In the spectrum analysis mode, when the sweep type is sweep frequency, the signal/spectrum analyzer digitally controls the LO for step sweep at a minimal frequency. During the entire sweep period, the number of sampling points captured by the ADC in the digital IF circuit is usually much larger than the number of sweep points used for display by the signal/spectrum analyzer. When the sweep type is FFT, the signal/spectrum analyzer will tune the LO to a fixed frequency point. During the entire measurement period, the number of sampling points

captured by the ADC in the digital IF circuit may also be greater than the number of sweep points used for display by the signal/spectrum analyzer after FFT calculation.

For example, we assume an ADC sampling rate of 100MSa/s, a sweep count of 1000, a sweep time of 100ms, and a bandwidth of 1GHz. When sweep is performed once, the signal/spectrum analyzer captures  $100 \times 10^5$  sampling points, which need to be converted into 1001 pieces of trace data. In other words, every 100,000 pieces of sampling data correspond to a point of trace data, and each trace data represents signals occurring within a frequency range of 1MHz. If the number of sweep points is increased, the corresponding bandwidth of each track data will be narrower, the measurement results will be more stable, and the frequency reading accuracy will be higher.

It can be seen from the above analysis that track display requires processing more sampling data points into fewer sweep track points, which is what track detection needs to do.

There are many types of trace detection modes, and there are 7 trace detection modes of S4052 series signal/spectrum analyzer:

**Normal detection**

Take the maximum and minimum values from the sampling data assigned to each track point and display them simultaneously.

**Positive peak detection**

Take a maximum value from the sampling data assigned to each track point and display it.

**Negative peak detection**

Take a minimum value from the sampling data assigned to each track point and display it.

**Sample value detector**

Take the last value from the sampling data assigned to each track point and display it.

**Power average detection**

Also known as RMS detection, it is used to calculate the mean square value of all sampled data assigned to each trace point. The S4052 series signal/spectrum analyzer detects the RF input signal envelope to obtain linear voltage values, squares these voltage values, divides them by the number of sampled data points corresponding to each trace point, and finally performs the root operation. When the display scale type is logarithmic, these root-mean-square values are transformed by 20 times logarithmic base 10 to obtain trace data. When the display scale type is linear, these root-mean-square values are track data.

**Voltage average detection**

Also known as average (AVG) detection, it is used to conduct linear average on all sampled data assigned to each trace point; The S4052 series signal/spectrum analyzer detects the RF input signal envelope to obtain linear voltage values. These voltage values are summed and divided by the number of sampling data points corresponding to each trace point. When the display scale type is logarithmic, these root-mean-square values are transformed by 20 times logarithmic base 10 to obtain trace data. When the display scale type is linear, these average values are track data.

**Video average detection**

It is also called log power average detection, which is used to find the log power average of all data assigned to each trace point. Early signal/spectrum analyzers typically displayed log scale measurement traces, all filtering and averaging were based on log power data, and the traces were often referred to as video signals. With the use of digital IF processing technology, the S4052 series signal/spectrum analyzer adds a video average detection function to achieve the same measurement results as earlier signal/spectrum analyzers.

The trace detection mode of the S4052 series signal/spectrum analyzer can be set manually or set to automatic selection. When selecting the detection mode automatically, the signal/spectrum analyzer will automatically select the appropriate detection mode based on the current trace processing mode, marker function and trace average type.

## 2) Concept of trace processing

When the signal/spectrum analyzer is in the continuous sweep state or has made several sweep and measurements continuously, the trace processing mode determines how the current measuring trace is processed with the previous measuring trace, so as to obtain the new

## 4.1 Function Operation Guide

trace.

There are four ways to process the trace for S4052 series signal/spectrum analyzer:

### **Refresh**

The new track is assigned directly to the current measuring track, independent of the previous measuring track.

### **Avg**

According to the set average times N in [Measurement Setting], the updated trace is obtained after exponential average of the measuring trace.

The specific algorithm is as follows:

New track = ((k-1) previous track + current measuring track) /K

Where, K is the average cumulative times.

In the continuous measurement state, once the K value accumulates to the set average times N in [Measurement Setting], K will always be equal to N. In the single measurement state, the measurement will stop once the K value accumulates to the average times N set in [Measurement Setting].

### **Max Hold**

The new track data is assigned with the maximum value of the previously measured track data.

### **Min Hold**

The new track data is assigned with the minimum value of the previously measured track data.

When one trace is activated each time, the default trace processing mode of S4052 series signal/spectrum analyzer is refreshing.

## 3) Trace display/hiding

Trace display/hiding Indicates whether the track is processed and displayed in the front panel display area. S4052 series signal/spectrum analyzers have four types:

### **Refresh and display**

The new track is refreshed in the application (called background) and displayed in the front panel display area.

### **Static display**

When the trace [Display/Hide] is set to "Static Display", the signal/spectrum analyzer will keep the latest trace, with no further trace processing, and display the latest trace to the front panel display area.

### **Background refresh**

The new trace is refreshed in the application (called background), but not displayed in the front panel display area. This type is often used in programmed control operations.

### **Hide**

The signal/spectrum analyzer neither performs background trace processing nor displays it, which is equivalent to that the trace is not activated and is in the OFF state.

When a trace is activated each time, the default trace display/hiding mode of S4052 series signal/spectrum analyzer is refreshing for display.

## 4) How do I activate and configure trace

The S4052 series signal/spectrum analyzer can activate a maximum of 6 traces simultaneously, which are respectively represented as trace 1, trace 2, trace 3, trace 4, trace 5 and trace 6. By default, the signal/spectrum analyzer activates only trace 1, the processing mode of trace 1 is "Refresh", the display/hiding setting of trace 1 is set to "Refresh Display", the detection of trace 1 is automatic by default, and the other five traces are hidden (OFF).

Press [Trace] to enter the [Trace Selection] submenu, and you can select and activate multiple traces. In order to better help you understand and reasonably configure the trace, we assume that the signal/spectrum analyzer is in the default state, that is, only trace 1 is activated, the processing mode of trace 1 is "Refresh", the display/hiding of trace 1 is set to "Refresh and Display", and the detection mode of trace 1 is automatically selected as normal detection. Follow the following steps to activate trace 2 and configure trace 2:

**Step 1. Select trace 2:**

Press the [Trace] key to enter the [Trace Selection] submenu and select trace 2. When the selection is complete, the signal/spectrum analyzer will automatically return to the previous menu. At this time, the soft key menu of [Trace Selection] will be displayed as [Trace Selection Trace 2], which means that the following setting of trace processing mode and trace display/hiding operations are only for trace 2.

**Step 2. Select a processing mode for trace 2 and activate trace 2:**

After pressing the [Refresh] soft key, the signal/spectrum analyzer will automatically activate trace 2, and set the processing mode of trace 2 to Refresh, set [Display/Hide] menu indication to [Refresh Display], and set the detection mode of trace 2 to Auto.

If you do not press the soft menu [Refresh], but directly enter the [Show/Hide] menu, and select [Refresh Display], the signal/spectrum analyzer will also activate trace 2, and set trace 2 processing mode to refresh mode, [Show/Hide] to [Refresh Display], and trace 2 detection mode to automatic. Returning to the previous menu, you can see that the refresh soft menu is active in light blue.

**Step 3. Select the processing mode of trace 2 as maximum holding and the detection mode as sampling detection:**

After pressing the [Maximum Holding] menu, trace 2 will be set to Maximum Holding for Processing, "\*" character appears in the [\*Max. Holding] menu. Meanwhile, the detection mode of trace 2 will be automatically set to the same automatic selection detection mode as trace 1, and the detection mode is the same.

After entering the [Detection] submenu and selecting detection as [Sample], trace 2 detection will be changed to manual sampling detection.

**NOTICE**

Because the S4052 signal/spectrum analyzer can only use one detection type at a time, changing the detection mode of any trace automatically changes the other active traces to the same detection type.

**5) Automatic trace average and automatic trace detection rules**

If the trace average type is set to automatic, the signal/spectrum analyzer will automatically select the average type based on the detection type, marker function, amplitude scale, etc., of the corresponding trace. The rules for automatic selection of the average type are as follows: if the trace detection (refer to the relevant content in Section 4.1.3 for detection) is the average power average, the average type is selected to be power average; if the trace detection (refer to Section 4.1.3 for the detection) is voltage average, the average type is selected to be voltage average; if the noise marker, bandwidth power or bandwidth density of the marker function (refer to 4.1.3 for the marker function) is enabled, the average type is selected to be power average; if the amplitude scale is selected to be linear scale (for details about the amplitude scale, refer to 4.1.2.4), the average type is set to voltage average; otherwise, the average type is set to video average.

If trace detection is set to automatic, the signal/spectrum analyzer will automatically select the detection type based on the processing method of the corresponding trace, average type, marker function, amplitude scale, etc. The rule of automatic selection of detection type is: If any function of noise marker, bandwidth power or bandwidth density function is enabled in the marker function of the current trace, the detection mode automatically selects the power detection type. If the trace average type is power average, the detection mode automatically selects the power detection type. If the trace processing mode is maximum hold, the detection mode automatically selects the maximum detection type. If the trace average is the voltage average, the trace detection automatically selects the voltage average detection. If the amplitude scale is linear scale, the detection mode is voltage average detection. If the trace average type is set to video average, video average detection is automatically selected. If the trace is treated as minimum hold, the minimum detection is automatically selected; otherwise, the normal detection is automatically selected.

If the trace average type and trace detection type are both in automatic mode, their automatic rules operate only based on the most recent settings. For example, if the latest operation is set to the trace average type, the automatic rule for detection type is used. If the latest

#### 4.1 Function Operation Guide

operation is set to the detection type, the automatic rule for average type is used.

##### 6) Clear a trace and clear all traces

Clearing a trace restores the currently selected trace data of the signal/spectrum analyzer to the default value. If the current trace processing mode is not minimum hold, the trace clearing operation will reset the trace data to the minimum state. If the current trace processing mode is minimum hold, the trace clearing operation will reset the trace data to the maximum state.

Clearing all traces restores all trace data of the signal/spectrum analyzer to default values. If the current trace processing mode is not minimum hold, the trace clearing operation will reset the trace data to the minimum state. If there is a trace that is treated as a minimum hold, the trace clearing operation will reset the trace data to a maximum state.

Clearing a trace and clearing all traces don't change any of the instrument's variables and setting parameters.

##### 7) Open and use trace operation

The function of trace operation refers to the operation and processing of two pieces of trace data. The signal/spectrum analyzer can perform trace operations on any two of the six active traces and save the operation results to the updated data of the result traces. The trace operations in the S4052 series signal/spectrum analyzers include addition and subtraction operations.

The trace operation rules are used to specify the data types of the two traces involved in the operation, including log power, linear voltage (current), or linear power.

Press the [Trace] key and [More...] menu to enter the [Trace Operation] submenu, and perform the trace operation. The specific steps are as follows:

###### Step 1. Select the path corresponding to operator 1 through the [Operator 1 Selection] menu:

Press the [Operator 1 Selection] menu to select any trace from trace 1 to trace 6.

###### Step 2. Select the path corresponding to operator 2 through the [Operator 2 Selection] menu:

Press the [Operator 2 Selection] menu to select any trace from trace 1 to trace 6.

###### Step 3. Perform trace addition:

Press the [Operator 1+ Operator 2-> Operator 2] menu, and the signal/spectrum analyzer will automatically activate the trace operation, add the trace corresponding to operator 1 and the trace corresponding to operator 2, and save the result in the trace corresponding to the result.

###### Step 4. Perform trace subtraction:

Press the [Operator 1- Operator 2-> Operator 2] menu, and the signal/spectrum analyzer will automatically activate the trace operation, subtract the trace corresponding to operator 1 and the trace corresponding to operator 2, and save the result in the trace corresponding to the result.

###### Step 5. Modify the operation rules:

Press the [Operation Rule] menu to change the type of the two pieces of trace data involved in the operation. By default, the operation rule is log.

###### Step 6. Disable trace operation:

Press the [Off] menu and the signal/spectrum analyzer disable the trace operation.

## NOTICE

To obtain the results of a trace operation, a sweep measurement must be performed. During the course of trace operation, operations such as clearing traces, loading traces and copying traces from files may affect the result of trace operation. Please try to avoid this situation.

### 8) Understand the relationship between trace processing and trace operation

Trace operation is a mathematical operation performed on the currently active trace (any two of the six traces) in a sweep, and trace processing is an average or hold processing performed on the trace obtained from multiple sweeps. Whenever the trace operation function is enabled, the operation rules are changed, or the operator selection is changed, the trace data saved in the operation result will be cleared, and then the sweep measurement will be performed again.

After obtaining the trace, the trace operation is performed first, and then the trace processing is performed. Finally, the processing results are saved into a new trace for display or transmitted to the user through the programmed control interface. The detailed relationship is shown in Figure 4.3.

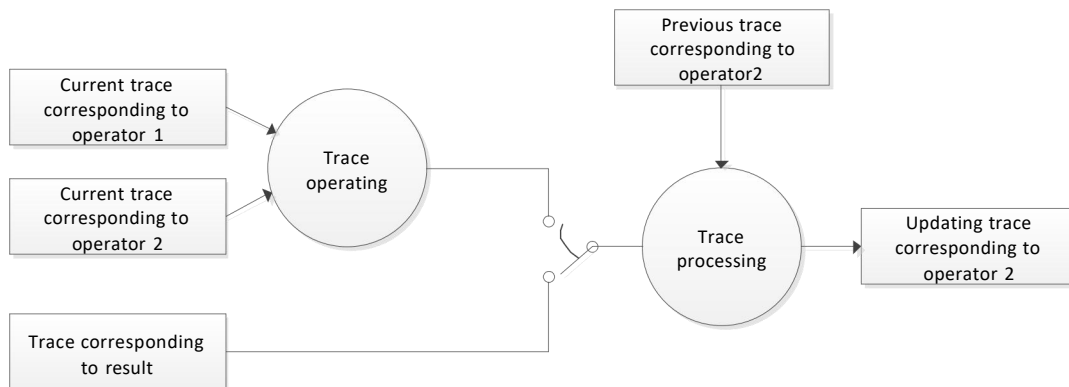

Figure 4.3 Relationship between trace processing and trace operation

Figure 4.4 shows the relationship between trace operation and trace processing corresponding to operator 2. When the trace operation function is enabled, the current trace data of trace processing comes from the result of trace operation; when the trace operation function is disabled, the current trace data of trace processing comes from the currently obtained trace, and then the trace is updated after the trace processing is averaged or maintained with the previous trace. The updated trace is used for display or transmission to the user via a programmed control interface.

The signal/spectrum analyzer always performs trace operation and trace processing on all active traces in the order of trace 1, trace 2, and all the way to trace 6. The performing order of traces is important here. For example, if the trace corresponding to operator 1 is trace 1 and the trace corresponding to operator 2 is trace 2, when trace 2 is performed, the current trace corresponding to operator 1 is the trace data that has been subjected to detection, and trace average/hold processing.

### 9) Trace copy operation

Trace copy is used to help you copy the selected trace data (for example, trace 1) to any other selected trace (for example, trace 2). Note that trace copy is only an operation, not a parameter setting, so it is not performed for every sweep measurement, but only once.

You can press the [Trace] key and [More...] menu to enter the [Trace Copy] submenu, and perform the trace copying operation. Assuming we want to copy the data from trace 2 to trace 3, we can do as follows:

#### Step 1. Select trace 2 from the [Source Trace] menu

After entering the [Trace Copy] sub-menu, press the [Source Trace] menu and select Trace 2.

#### Step 2. Select trace 3 from the [Target Trace] menu

After entering the [Trace Copy] sub-menu, press the [Target Trace] menu and select Trace 3.

#### Step 3. Copy trace

After entering the [Trace Copy] sub-menu and pressing the [Trace Copy] menu, the signal/spectrum analyzer will perform a trace copying operation.

## 4.2 Advanced Operation Guide

### 4.1.3.2 Using markers

Marker can help you quickly select and read specific track data. It can accurately locate the position of a measurement data in the track, obtain the data information, and indicate its position. Each activation window of S4052 signal/spectrum analyzer can activate a maximum of 12 markers.

The marker function is a more complex measurement process and calculation function based on the marker measurement, which can help you to carry out noise measurement, signal demodulation and high precision frequency measurement and other test tasks.

This section describes the basic concepts and operations of markers and marker functions. The marker function is not available for all measurement modes and measurement functions. The corresponding menu is not displayed in the measurement function without the marker or marker function.

#### 3) Marker type

S4052 series signal/spectrum analyzers have three types of markers:

##### Normal markers

It indicates that the marker is a positional marker. Normal markers can move on the trace point by specifying the horizontal axis coordinate value, and the corresponding trace value is the absolute value of the vertical axis.

##### Difference marker

It indicates that the marker is a numeric tag, and the difference marker indicates the relative value between the selected marker and its reference marker. The difference marker can be moved on track data by specifying the relative value of the horizontal coordinate between its reference marker and the difference marker.

##### Fixed marker

It indicates that the marker is a positional marker. A fixed marker, as the name suggests, is a marker that is fixed in a specified position. The fixed marker can be moved by specifying its horizontal and vertical coordinates, or by the peak search function. After being moves, it will be fixed again. If the normal marker or the delta marker is changed into a fixed marker, the horizontal axis coordinate position and the vertical axis coordinate value corresponding to the marker will be fixed.

#### 4) Active marker

Each marker corresponds to a trace, so the marker can only be activated if there is a trace display in the current active window. If you close the trace display in the current active window, the marker and marking functions of the corresponding trace are also automatically closed. Active markers are indicated by white rhombuss at their corresponding screen locations.

By default, press the [Marker] key and the S4052 signal/spectrum analyzer will automatically activate marker 1. The mark type is normal. The trace corresponding to marker 1 is the currently selected trace, and the marker position will be placed as the center of the display area, that is, the center of the X-axis coordinate.

Enter the [Marker Selection] menu and select another marker by using the soft key. The signal/spectrum analyzer automatically activates this marker and set it to the common marker.

## 4.2 Advanced Operation Guide

This part introduces the relatively complex measurement operation process of S4052 series signal/spectrum analyzer.

Measure Small Signal	73
OBW	78
Adjacent Channel Power	78
Power Statistics	80
Burst Power	82
Harmonic Distortion	84

Third-order Intermodulation	86
Spurious Emission	88
Spectrum Emission Mask	89

### 4.2.1 Measure Small Signal

The noise generated inside the signal/spectrum analyzer determines its ability to measure small signals. The following methods aim to, by changing the measurement settings, improve the measurement sensitivity of the analyzer.

#### 4.2.1.1 Reducing the Attenuation of the RFAttenuator to Measure Small Signals

The input attenuator affects the level of the input signal. If the input signal is very close to the noise floor, reducing the amount of attenuation of the attenuator can extract the signal from the noise.

## NOTICE

The total power of all signals input to the signal/spectrum analyzer should be ensured to be less than +30dBm (1W)!

#### Step 1. Reset the signal/spectrum analyzer:

Press [RST].

#### Step 2. Set up the signal generator and connect the signal/spectrum analyzer:

Set the frequency of the signal generator to 300MHz and the amplitude of it to -80dBm, and connect the RF output end of the signal generator to the RF input end of the signal/spectrum analyzer.

#### Step 3. Set the center frequency, span and reference level of the signal/spectrum analyzer:

Press [Frequency], [Center Frequency], and enter 300MHz.

Press [Span/Horizontal Axis], [Span], and enter 5MHz.

Press [Amplitude/Vertical Axis], [Ref Level] and input -40 [dBm].

#### Step 4. Move the signal peak to the center frequency (300MHz in this case):

Press [Peak Search] → [Marker → Center Freq].

#### Step 5. Reduce the span to 1MHz and repeat Step 4 if necessary to ensure that the signal peak is at the center frequency of the signal/spectrum analyzer:

Press [Span/Horizontal Axis], [Span], and enter 5MHz.

as shown in Figure 4.4.

4.2 Advanced Operation Guide



Figure 4.4 Small signal at 10dB of the attenuator by default

**Step 6: set the amount of attenuation of the attenuator to 20dB:**

Press [Amplitude], [Mechanical attenuation], and input 20dB.

As can be seen in Figure 4 5 increasing the attenuation of the attenuator brings the noise base closer to the signal level.



Figure 4.5 Small signal at 20dB of the attenuator

**Step 7. In order to observe the measured signal more clearly, set the attenuator to 0dB:**

Press [Amplitude], [Mechanical attenuation], and input 0dB.

Figure 4.6 shows the measured signal displayed by the signal/spectrum analyzer when the attenuator decays to 0dB.



Figure 4.6 Small signal at 0dB of the attenuator

## NOTICE

After this test is complete, remember to restore the attenuation value of the signal/spectrum analyzer to protect the RF input port of the signal/spectrum analyzer.

Press [AMP]→[Mechanical ATTEN AUTO MAN].

### 4.2.1.2 Reduce resolution bandwidth to measure small signal

The resolution bandwidth affects the internal noise floor of the signal/spectrum analyzer, but has no effect on the level of the measured continuous wave signal. The relationship between the amount of noise reduction and resolution bandwidth can be expressed by the following formula:

$$\Delta L = 10 \log \frac{BW_1}{BW_2}$$

Where:  $\Delta L$ —the amount of change in noise amplitude in dB.

$BW_1$ ,  $BW_2$ —different resolution bandwidth, Hz.

So when the resolution bandwidth is reduced by 10 times, the noise floor is reduced by 10 dB.

#### Step 1. Reset the signal/spectrum analyzer:

Press [RST].

#### Step 2. Set up the signal generator and connect the signal/spectrum analyzer:

Set the frequency of the signal generator to 300MHz and the amplitude of it to -80dBm, and connect the RF output end of the signal generator to the RF input end of the signal/spectrum analyzer.

#### Step 3. Set the center frequency, span and reference level of the signal/spectrum analyzer:

Press [Frequency], [Center Frequency], and enter 300MHz.

Press [Span/Horizontal Axis], [Span], and enter 5MHz.

Press [Amplitude/Vertical Axis], [Ref Level] and input -40 [dBm].

#### Step 4. Use the step key [↓] to reduce the resolution bandwidth:

Press [Bandwidth]→[Resolution Bandwidth] and [↓] .

## 4.2 Advanced Operation Guide

As the noise floor is reduced, it can be seen that the signal gradually becomes clear, as shown in Figure 4.7.

As reducing the resolution bandwidth causes an increase in sweep time, the S4052 series signal/spectrum analyzer has a resolution bandwidth of 1 Hz to 3MHz in 10% steps. Choosing the appropriate resolution bandwidth allows for a finer compromise between sweep time and resolution bandwidth.

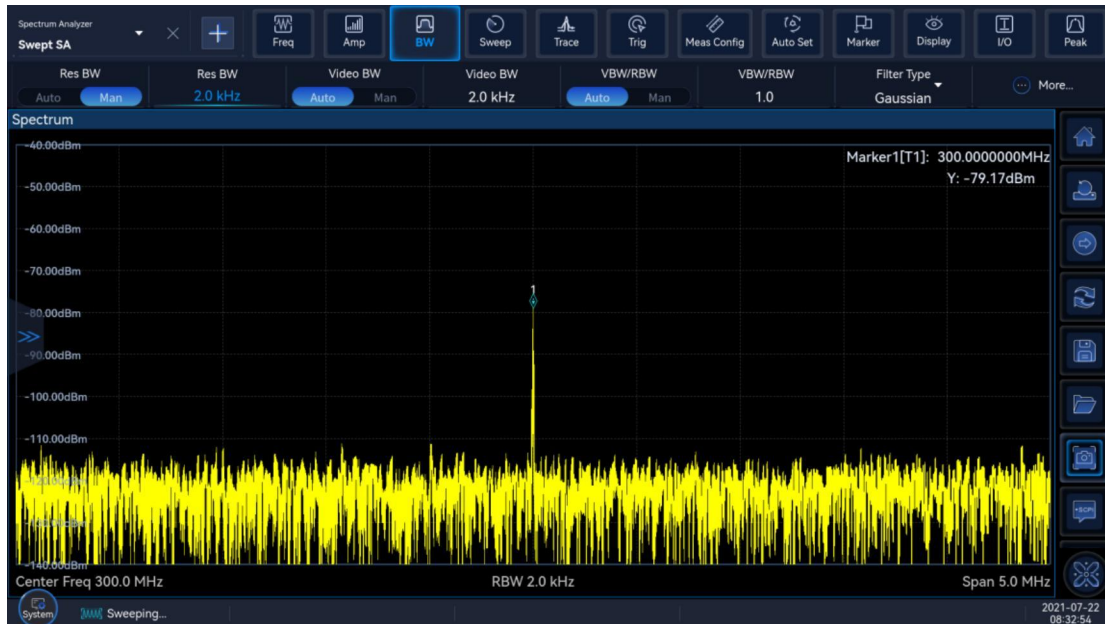

Figure 4.7 Measure small signal by reducing the resolution bandwidth

### 4.2.1.3 Measuring the Small Signal Using the Average Detection and Increasing the Sweep Time

When the noise floor of the signal/spectrum analyzer covers small signals, the application of average detection mode and the increase of sweep time can smooth the noise and improve the visibility of the signal. A slower sweep time results in a better average noise variance.

#### Step 1. Reset the signal/spectrum analyzer:

Press [RST].

#### Step 2. Set up the signal generator and connect the signal/spectrum analyzer:

Set the frequency of the signal generator to 300MHz and the amplitude of it to -80dBm, and connect the RF output end of the signal generator to the RF input end of the signal/spectrum analyzer.

#### Step 3. Set the center frequency, span and reference level of the signal/spectrum analyzer:

Press [Frequency], [Center Frequency], and enter 300MHz.

Press [Span/Horizontal Axis], [Span], and enter 5MHz.

Press [Amplitude/Vertical Axis], [Ref Level] and input -40 [dBm].

#### Step 4. Select the detection method of the signal/spectrum analyzer as the average detection:

Press [Trace], [Detection Method] and [Video Average].

#### Step 5. Increase the sweep time of signal/spectrum analyzer:

Press [Sweep], [Sweep Type], [Sweep Frequency], [Sweep Time], and use the step key [↑] to increase the sweep time.

Increasing the sweep time allows more data to average the each trace pixel point, as shown in Figure 4.8.



Figure 4.8 Small signal after increasing the sweep time

#### 4.2.1.4 Measure Small Signals by Using Video Average

The video average uses the digital processing method to average the average value of the currently swept track points and the previous positions of the same track. Enable the video averaging and the signal/spectrum analyzer automatically sets the detection mode to sampling detection. Sampling detection is less accurate at measuring signal peaks than normal detection, because sampling detection often fails to find the true peak of the signal. The video averaging function and the average detection get different results.

##### Step 1. Reset the signal/spectrum analyzer:

Press [RST].

##### Step 2. Set up the signal generator and connect the signal/spectrum analyzer:

Set the frequency of the signal generator to 300MHz and the amplitude of it to -80dBm, and connect the RF output end of the signal generator to the RF input end of the signal/spectrum analyzer.

##### Step 3. Set the center frequency, span and reference level of the signal/spectrum analyzer:

Press [Frequency], [Center Frequency], and enter 300MHz.

Press [Span/Horizontal Axis], [Span], and enter 5MHz.

Press [Amplitude/Vertical Axis], [Ref Level] and input -40 [dBm].

##### Step 4. Turn on the video average feature:

Press [Trace], [Display Mode], [Average]. As the instrument averages the trace continuously, the small signal becomes more and more clear. The default average number of times is 100.

##### Step 5. Set the average times to 25:

Press [Measurement Settings] and [Average Times].

Enter 25 from the number input area on the front panel. Press [←→], or the [OK] key in the soft menu, as shown in Figure 4.9.

At this time, in the state area on the left side of the screen, the average times is changed to 25. Once the average times you set is reached, the signal/spectrum analyzer will continue to average the data. If you want the measurement to stop after reaching the average number of times, you can use the Single Sweeping function. Press [Swp]→[Swp CONT SGL].

## 4.2 Advanced Operation Guide

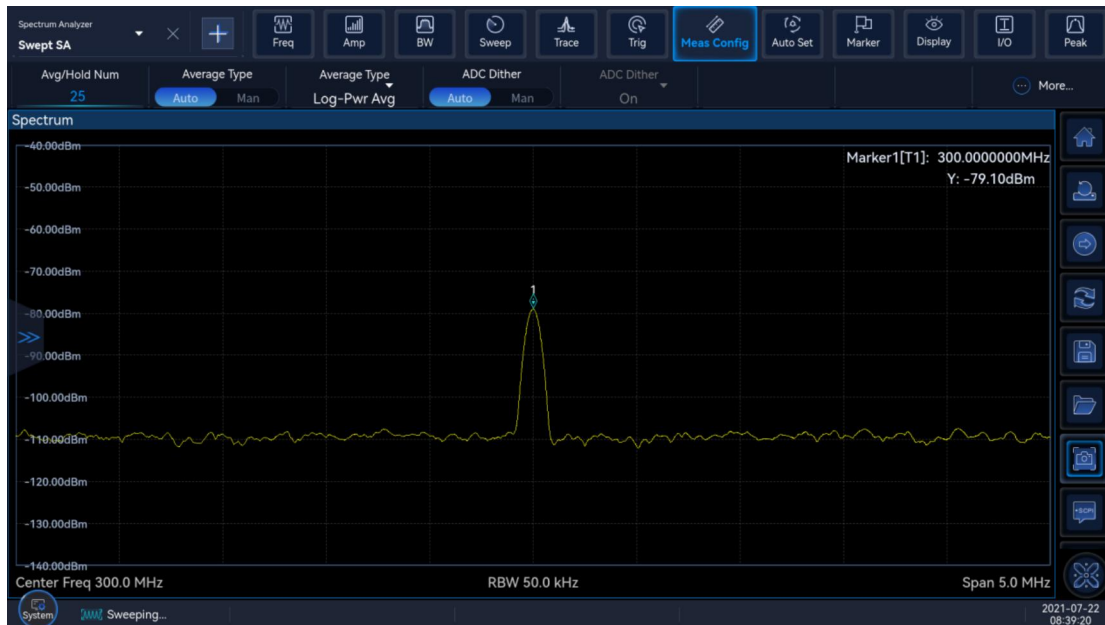

Figure 4.9 Measuring Small Signals with Trace average

## 4.2.2 Occupied Bandwidth

## 4.2.2.1 Basic Concept

The occupied bandwidth power shows the power of the spectrum, and markers are set at frequencies that contain a specific portion of the power. This measurement is set to 99% of the total power by default. First, the combined power of all signal responses in the trace is calculated. For the occupied power bandwidth, 99% of the power is distributed inside the two vertical markers, and 1% of the power is distributed outside the vertical markers. The difference between the vertical markers is the bandwidth that consumes 99% of the power.

The bandwidth measurement also shows the difference between the center frequency of the signal/spectrum analyzer and the center frequency of the channel, which is called the carrier frequency error.

Users can set their own measurement parameters. Press the [+] key to select the [Occupied Bandwidth] menu, and press the [Measurement Settings] key to enter the measurement parameter setting menu. Single or continuous measurement methods can be selected through the shortcut menu on the right side of the interface.

## 4.2.2.2 Measurement Example

This section mainly describes how to measure the bandwidth occupied by W-CDMA(3GPP) (using a signal generator to simulate a W-CDMA signal), measure the total power within the bandwidth, and calculate the bandwidth occupied by 99.0% of the total power.

**Step 1. Set the signal source as follows:**

Set the mode to W-CDMA.

Set the signal source frequency to 1.960GHz.

Set the signal amplitude to -10dBm.

**Step 2. Connect the RF output port of the signal source to the RF input port of the analyzer, as shown in Figure 4.10:**

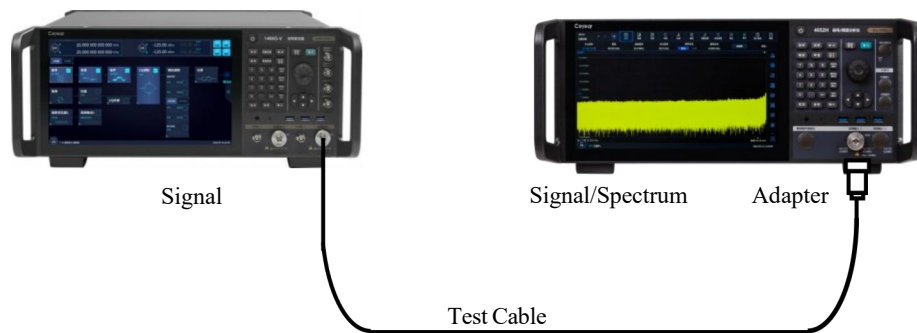

Figure 4.10 Connection setting of occupied bandwidth measurement

**Step 3. Set the analyzer to spectrum analysis mode and activate the occupied bandwidth measurement:**

Press the [+] key in the upper left corner of the screen to select the [Spectrum Analysis] mode.

Set the measurement function to [Occupied Bandwidth].

**Step 4. Set the wireless standard and switch the wireless device to the base station:**

Press [Measurement Settings], [More], [Wireless Standards], [W-CDMA 3GPP].

Set the wireless standard to W-CDMA.

Press [Wireless Device], [BTS].

Switch the wireless device to BTS.

**Step 5. Set the analyzer frequency to 1.960GHz:**

Press [Frep] → [Center Freq].

Set the center frequency of the instrument and enter 1.960GHz.

The measurement results of occupied bandwidth are shown in Figure 4.11.



Figure 4.11 Occupied bandwidth measurement result

**Step 6. Change the measurement parameters:**

Press [Measurement Settings], [More], and [Functional Parameters]

## 4.2 Advanced Operation Guide

You can modify measurement parameters such as the occupied power % and xdB as required.

### 4.2.3 Adjacent Channel Power

#### 4.2.3.1 Basic Concept

Adjacent channel power is used to represent the power leaking into adjacent channels. Depending on the selection of different wireless communication standards, adjacent channel power measurement can be used to measure different types of signals.

If the bandwidth integration method is chosen, a trace sweep is performed to calculate the in-band power relative to each offset. Depending on the reference type selected, the result is displayed as the corresponding total power or power spectrum density. Users can choose between spectrum display or bar chart display to observe the measurement results.

After creating the [Adjacent Channel Power] function, press the [Measurement Settings] key to create a detailed menu for setting measurement parameters.

#### 4.2.3.2 Measurement Example

Adjacent channel power measures the total power within a specified channel and the power of 8 pairs of offset channels. The measured results give the ratio of the power of the offset channel to that of the main channel. This section mainly describes how to perform adjacent channel power measurement for W-CDMA (3GPP) (using a signal generator to simulate a W-CDMA signal).

##### Step 1. Set the signal source as follows:

Set the mode to W-CDMA.

Set the signal source frequency to 1.960GHz.

Set the signal amplitude to -10dBm.

##### Step 2. Connect the RF output port of the signal source to the RF input port of the analyzer, as shown in Figure 4.12:

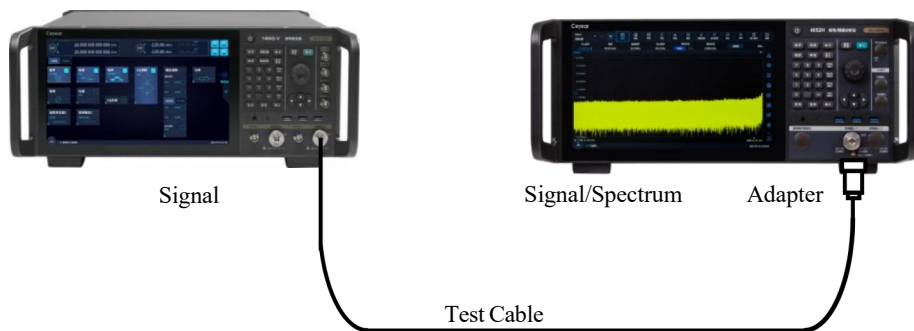

Figure 4.12 Settings of adjacent channel power measurement connection

##### Step 3. Reset the analyzer:

Press [RST].

##### Step 4. Initialize the adjacent channel power measurement:

Press +, select the [Spectrum Analysis] mode and add [Adjacent Channel Power].

##### Step 5. Set the wireless standard and switch the wireless device to the base station:

Press [Measurement Settings], [Wireless Standards], [W-CDMA].

Set the wireless standard to W-CDMA.

Press [Measurement Settings], [More], [Basic Settings], [Wireless Devices], [Base Station].

Switch the wireless device to base station.

##### Step 6. Set the analyzer frequency to 1.960GHz:

Press [Frep] → [Center Freq].

Set the center frequency of the instrument and enter 1.960GHz.

The adjacent channel power measurement results are shown in Figure 4.13. The measurement parameters, such as offset frequency, integral bandwidth, and span settings, use the default settings of the reference wireless standard.



Figure 4.13 Adjacent channel power measurement result

#### Step 7. Define a new third offset pair:

Press [Measurement Settings], [More ], [Offset Channel], [C].

Select a new offset channel C.

Find the [Basic Parameters].

Set the offset C ON/OFF to ON and the offset frequency to 15MHz.



Figure 4.14 Measuring the third adjacent channel

#### Step 8. Set pass/fail limits for each offset:

Press [Measurement Settings], [More ], [Offset Channel ], [A], [Limit ], [Relative Limit (Car)].

Set the limit for offset A, and enter -55dB.

Press [Measurement Settings], [More ], [Offset Channel ], [B], [Limit ], [Relative Limit (Car)].

Set the limit for offset B, and enter -80dB.

4.2 Advanced Operation Guide

Press [Measurement Settings], [More ], [Offset Channel ], [C], [Limit ], [Relative Limit (Car)].

Set the limit for offset C, and enter -55dB.

**Step 9. Enable the limit test:**

Press [Measurement Settings], [Limit Test ON OFF].

Set the limit test to ON.

In Figure 4.15, offsets A and C pass and offset B fails. The power level in offset B exceeds the -80dB we specified, so it fails. The bar chart of the failed channel will be shown in red.



Figure 4.15 Limit test

4.2.4 Power Statistics

4.2.4.1 Basic Concept

CCDF measurement is a statistical measurement of high level signal power or peak power. It reflects the percentage of time that the signal exceeds its average power through graphs and tables, as well as the exceeded value.

The power-complementary cumulative distribution function curve describes the high level power of the signal. It gives a distribution of the peak-to-average power ratio with the corresponding probability. The CCDF curve is the amount of time that the waveform is equal to or greater than the specified power level. The percentage of time a signal spends at or above that level is defined as the probability of that specified power level.

4.2.4.2 Measurement Example

This section mainly describes how to perform CCDF power statistics and measurements of W-CDMA(3GPP) signals (using a signal generator to simulate a W-CDMA signal).

**Step 1. Set the signal source as follows:**

Set the mode to W-CDMA.

Set the signal source frequency to 1.960GHz.

Set the signal amplitude to -10dBm.

**Step 2. Connect the RF output port of the signal source to the RF input port of the analyzer, as shown in Figure 4.16:**

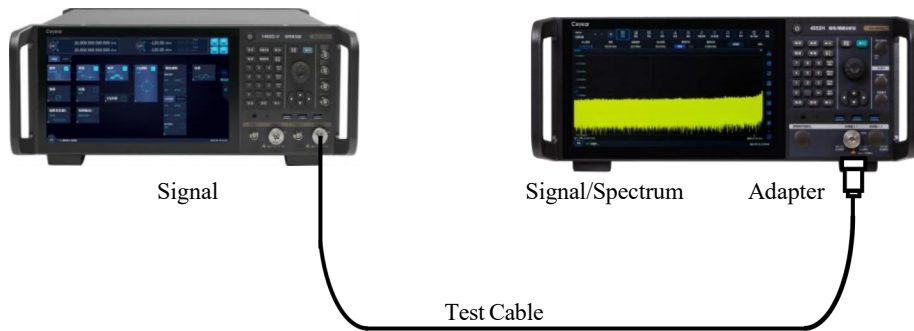

Figure 4.16 Connection settings for power statistics and measurement

**Step 3. Create the power statistics function:**

Press the "+" button at the top left of the instrument screen to create a new [Power Statistics].

**Step 4. Set the analyzer frequency to 1.960GHz:**

Press [Frep] → [Center Freq].

Set the center frequency of the instrument and enter 1.960GHz.

The power statistics and measurement results are shown in Figure 4.17.



Figure 4.17 Power statistics measurement result

**Step 5. Store the current measurement trace as a reference:**

Press [Trace], [Reference Trace].

Store the current measurement trace as a reference trace. When the CCDF power statistics and measurements are performed for the first time, the graph displayed is a typical pure noise signal, marked as a Gaussian curve in pink. The CCDF curve currently measured is shown in yellow, and the reference curve stored for comparison is shown in green.

**Step 6. Display the stored reference trace:**

Press [Trace], [Reference Trace ON OFF].

Set the reference trace to ON and open the stored reference trace, as shown in Figure 4.18.

4.2 Advanced Operation Guide



Figure 4.18 Storing and displaying CCDF measurements

**Step 7. Modify the range to optimize special measurements:**

Press [Amplitude], [Range].

Set the scale of the horizontal axis to 10dB, as shown in Figure 4.19.



Figure 4.19 Modifying the measurement range

4.2.5 Burst Power

4.2.5.1 Basic Concept

Burst power measurement is an accurate method of measuring the specified burst average power. It measures the average power of the captured pulse at zero span. This measurement is mainly used for measurement on the pulse modulation signal and burst signal in time domain. If there is no user definition, the pulse width can be obtained by finding the peak in the captured data, and then finding the first position on the trace above the threshold, that is, the starting point of the pulse, and the end point of the pulse is the first point on the trace below the threshold. The average carrier power can be calculated from the pulse width and threshold.

#### 4.2.5.2 Measurement Example

This section describes how to measure the burst power of a pulse modulation signal with a frequency of 1.0GHz (using a signal generator to simulate a pulse modulation signal).

**Step 1. Set the signal source as follows:**

Set a pulse modulation signal.

Set the signal source frequency to 1.960GHz.

Set the pulse modulation signal period to 100us.

Set the signal amplitude to -10dBm.

**Step 2. Connect the RF output port of the signal source to the RF input port of the analyzer, as shown in Figure 4.20:**

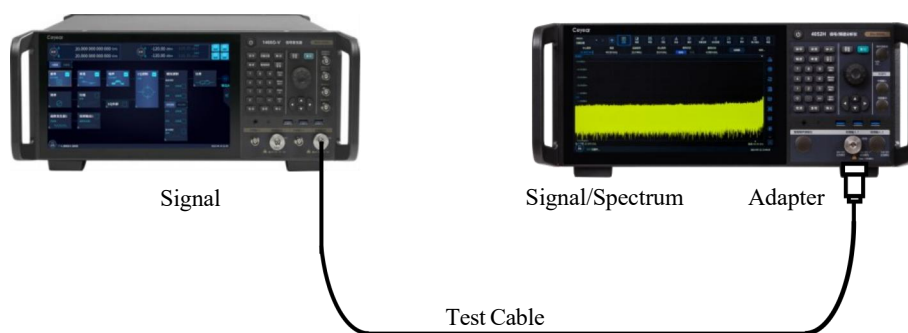

Figure 4.20 Burst power measurement connection settings

**Step 3. Set the analyzer to spectrum analysis mode and activate the burst power measurement:**

Press the [+] key in the upper left corner of the screen to select the [Spectrum Analysis] mode.

Set the measurement function to [Burst Power].

**Step 4. Set the analyzer frequency to 1.960 GHz:**

Press [Frep] → [Center Freq].

Set the center frequency of the instrument and enter 1.960GHz.

**Step 5. Set the sweep time of the analyzer to 200.0us:**

Press [Swp] → [Sweep Time].

Set the sweep time of the instrument, and enter 200.0us.

**Step 6. Set the trigger mode of the analyzer to burst power trigger:**

Press [Trigger] and [Burst Power Trigger].

Set the trigger mode of the instrument and select the burst power trigger.

The burst power measurement results are shown in Figure 4.21.

4.2 Advanced Operation Guide



Figure 4.21 Burst power measuring result

**Step 7. Change the measurement parameters:**

Press [Measurement Settings], [More], and [Functional Parameters]

Users can change the threshold level, measurement method and other measurement parameters according to their needs.

4.2.6 Harmonic distortion

4.2.6.1 Basic Concept

The harmonic distortion of signal is measured in two ways.

Auto Search Carrier: At this point, the range list is closed, and the instrument automatically searches for the fundamental frequency signal and measures it and its harmonics. Specifically, for each harmonic being measured, the center frequency will be set to an integer multiple of the fundamental frequency and a sweep will be performed. The amplitude can be calculated by averaging the power of the trace and displayed in the result list in the window. The resolution bandwidth of each harmonic is the fundamental frequency resolution bandwidth multiplied by the number of harmonics. The value of the resolution bandwidth required for each harmonic is the number of harmonics times the resolution bandwidth of the fundamental wave. At the smallest resolution bandwidth available, this result is greater than or equal to the calculated value.

Range list method: Open the range list, set the desired list parameter state, and measure the fundamental wave based on the currently known list parameters. For each valid range table, set the center frequency to the frequency of the range table. If the current bandwidth is set to 0, the amplitude is calculated by averaging the power over the trace and is displayed in the list of results window.

After the specified number and amplitude of harmonics are measured, the total harmonic distortion results (Harmonics & THD) are displayed in the left of the window. If the measurement is in single sweep mode, the display will remain at the last harmonic setting and the instrument will stop sweep. If the measurement is in continuous sweep mode, the amplitude of the fundamental and harmonic waves will be continuously measured.

4.2.6.2 Measurement Example

This section introduces how to measure harmonic distortion of signals.

**Step 1. Set the signal source as follows:**

Set the signal source frequency to 1.960GHz.

Set the signal amplitude to -10dBm.

**Step 2. Connect the RF output port of the signal source to the RF input port of the analyzer, as shown in Figure 4.22:**

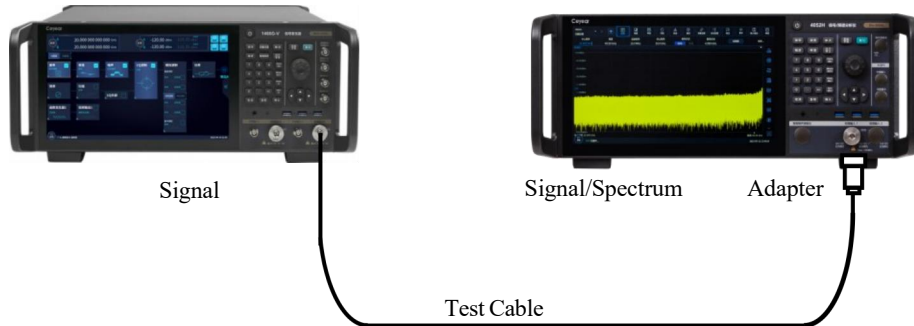

Figure 4.22 Harmonic distortion measurement connection settings

**Step 3. Set the analyzer to spectrum analysis mode and activate harmonic distortion measurement:**

Press the [+] key in the upper left corner of the screen to select the [Spectrum Analysis] mode.

Set the measurement function to [Harmonic Distortion].

**Step 4. Initialize harmonic distortion measurement, default to automatic fundamental wave search and harmonic wave measurement:**

[Measurement Method] Select Auto Search, default to automatic fundamental wave search and harmonic wave measurement;

The harmonic distortion measurement results are shown in Figure 4.23. The text window displays the absolute power value of the fundamental wave and the value of the harmonic wave relative to the fundamental wave, and gives the total harmonic distortion.

**Step 5. Manually set harmonic parameters. Users can edit the list to:**

Press [Measurement Settings], [More], [Functional Parameters], [Measurement Method].

Set the method to Harmonic List Method, which goes to Harmonic Edit List.

Users can select and set measurement parameters such as frequency, resolution, and bandwidth as needed.



Figure 4.23 Harmonic distortion measurement

### 4.2.7 Third Order Intermodulation

#### 4.2.7.1 Basic Concept

Third order intermodulation, abbreviated as TOI, is mainly used for the analysis and measurement of intermodulation products in communication system equipment. In communication systems, mutual interference between devices is a common problem, usually caused by distortion products generated by devices such as amplifiers and mixers in the system. The third-order intermodulation measurement calculates and displays the output intercept point (IP3), and the markers on the curve indicate the measured signal and third-order product.

After selecting [TOI], press [Measurement Settings] to enter the parameter setting menu of third order intermodulation measurement, and press the shortcut menu on the right side to switch between continuous and single sweep.

#### 4.2.7.2 Measurement Example

This section focuses on how to perform third-order intermodulation measurements of the device under test (DUT), using two signal generators to simulate the signals.

**Step 1. Connect the RF output ports of the two signal sources through a directional coupler, and place the DUT (such as an amplifier) between the output port of the directional coupler and the input port of the analyzer. The specific connection is shown in Figure 4.24.**

**Step 2. Set the signal source as follows:**

Set one signal source frequency to 497.5MHz

Set the frequency of another signal source to 502.5MHz, so that the interval between signal source frequencies is 5MHz.

Set the power of two signal sources so that the amplitude measured by the spectrum analyzer is equal. In this example, it is set to -10.0dBm.

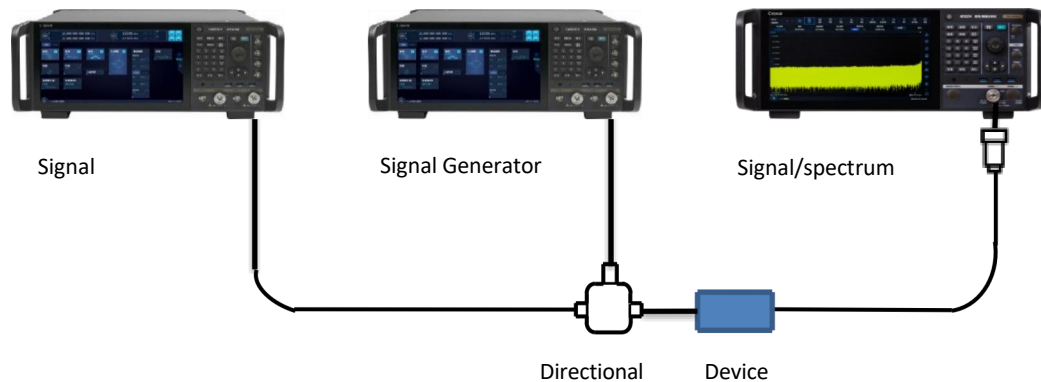

Figure 4.24 Third order intermodulation measurement connection settings

**Step 3. Set the analyzer to spectrum analysis mode and activate third-order intermodulation measurement:**

Press the [+] key in the upper left corner of the screen to select the [Spectrum Analysis] mode.

Set the measurement function to [TOI].

**Step 4. Set the center frequency of the analyzer to 500.0MHz:**

Press [Frep] → [Center Freq].

Set the center frequency of the instrument and enter 1.960GHz.

**Step 5. Set the span of the analyzer to 50.0MHz:**

Press [Frequency] and [Span].

Set the span of the instrument and input 50.0MHz.

The third-order intermodulation measurement results are shown in Figure 4.25. The text window displays the fundamental frequency and power, as well as the third-order intermodulation frequency and power, and provides third-order truncation values.

#### Step 6. Users can adopt zero span mode:

Press [Measurement Settings] and [Zero Span Mode ], [Zero Span Measurement ON OFF].

Users can set measurement parameters such as resolution bandwidth and dwell time as needed.



Figure 4.25 Third-order intermodulation measurement results

## 4.2.8 Spurious Emission

### 4.2.8.1 Basic Concept

Spurious Emission Measurement identifies and determines the power level of spurious emissions within a certain frequency band, and is primarily used to measure signal parasitics, harmonics, and intermodulation. In practical situations, spurious emission should be ensured at a lower power level, preferably close to background noise, to avoid interference with communication in other frequency bands.

### 4.2.8.2 Measurement Example

This section focuses on how to measure spurious emission by simulating pulse signal to measure spurious signals on the spectrum.

#### Step 1. Set the signal source as follows:

Set the pulse signal with a repetition rate of 1kHz.

Set the signal source frequency to 1.960GHz.

Set the signal amplitude to -10dBm.

#### Step 2. Connect the RF output port of the signal source to the RF input port of the analyzer, as shown in Figure 4.26:

4.2 Advanced Operation Guide

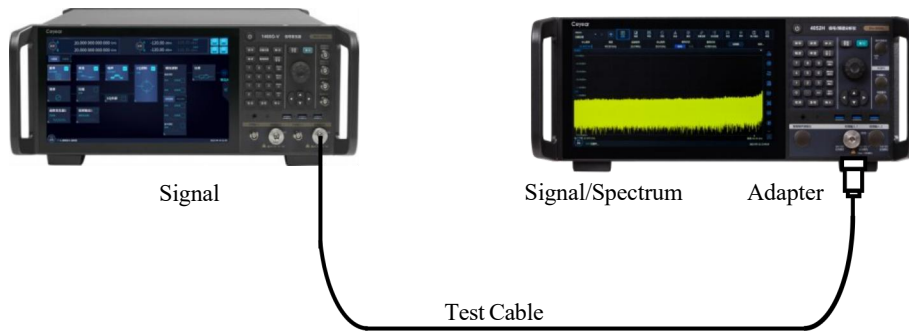

Figure 4.26 Spurious emission measurement connection settings

**Step 3. Set the analyzer to spectrum analysis mode and activate spurious emission measurement:**

Press the [+] key in the upper left corner of the screen to select the [Spectrum Analysis] mode.

Set the measurement function to [Spurious Emission].

**Step 4. Set the report display method:**

Press [Measurement Settings] and [Report Mode].

Select the overrun spurious display method.

The spurious emission measurement results are shown in Figure 4.27.

The text window displays the detected spuriousness. The information for each spurious includes the frequency range in which the spurious is located, the power of the spurious, and the limiting value.

**Step 5. Users can change the measurement parameters and customize the list of required measurement ranges:**

Press [Measurement Settings], [More], [Functional Parameters].

Users can select and edit measurement parameters from multiple lists as needed.



Figure 4.27 Spurious emission measurement results

4.2.9 Spectrum emission mask

4.2.9.1 Basic Concept

Spectral emission mask measurements include both in-band and out-of-band spurious emission, referred to as SEM. For the

measurement of spurious signals in the frequency band close to the carrier signal, the analysis bandwidth of spurious measurement with different frequency range offset relative to the carrier may be different. To facilitate observation and judge the indicators, the spurious limit level of each frequency range is given from the carrier signal according to the standard. All of these levels are connected to form the spectrum mask. The distribution of signal spurious must fall within this spectrum mask before it can be measured. Therefore, the spectrum mask can be very intuitive to observe and determine whether the spurious component of the signal exceeds the standard.

Detailed settings can be made for the relevant parameters of multi carrier measurement through the measurement settings key, and single or continuous measurement can be switched through the measurement control key.

#### 4.2.9.2 Measurement Example

This section focuses on how to perform spectrum emission mask measurements of 5GNR (3GPP) signals (using a signal generator to simulate a 5GNR signal). SEM compares the power within the specified carrier bandwidth and the power in the specified offset channel with the power level specified by the standard.

##### Step 1. Set the signal source as follows:

Set the 5GNR signal.

Set the signal source frequency to 1.960GHz.

Set the signal amplitude to -20dBm.

##### Step 2. Connect the RF output port of the signal source to the RF input port of the analyzer, as shown in Figure 4.28:

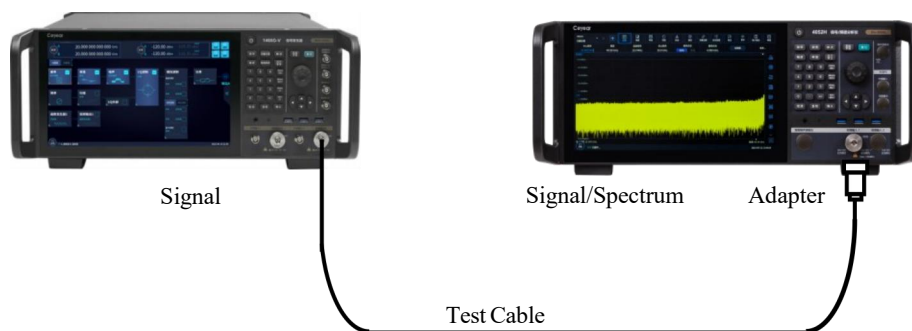

Figure 4.28 SEM measurement connection settings

##### Step 3. Set the analyzer to spectrum analysis mode and activate Spectrum Emission Mask measurement:

Press the [+] key at the top left of the instrument screen to select the [Spectrum Analysis] mode.

Set the measurement function as Spectrum Emission Mask Measurement.

##### Step 4 Set wireless standard protocol:

Press the instrument screen [Measurement Settings] - [Protocol Standards] or [Measurement Settings] - [More] - [Standard Protocol].

Select the 5GNR\_DL\_S1\_CateA\_BW05\_BS\_1\_C.xml file under the 5GNR folder and click the [Load] key.

##### Step 5. Set the frequency of the analyzer to 1.90GHz:

Press [Frep] → [Center Freq].

Set the center frequency of the instrument and input 1.90GHz.

The Spectrum Emission Mask Measurement results are shown in Figure 4.29. The text window displays the carrier power of the reference channel, as well as the absolute peak power level, relative power level, and limit difference within the offset frequency band on both sides of the reference channel.

## 5 Remote Control

### 5.1 Remote Control Basics



Figure 4.29 SEM measurement result

## 5 Remote Control

This chapter provides basic information on operating the S4052 signal/spectrum analyzer via remote control to facilitate remote control operation by users. Specific contents include:

Remote Control Basics.....	9 2
Instrument Programmed Control Port and Configuration.....	10 5
Basic VISA Interface Programming Method.....	10 6
I/O Library.....	1 0 9

### 5.1 Remote Control Basics

Programmed Control Interface .....	9 2
Message .....	9 4
SCPI Command .....	9 5
Command Sequence and Synchronization .....	1 0 2
Status Reporting System .....	1 0 3
Programming Considerations .....	1 0 5

#### 5.1.1 Remote Control Interface

S4052 signal/spectrum analyzer supports two remote control interfaces: LAN and GPIB. It is shown in the table below:

Table 5.1 Remote control interface type and VISA addressing string

Program control interface	VISA address string (Note 1)	Description
LAN (Local Area Network)	<b>Raw socket protocol:</b>	The controller realizes remote control by connecting the network

## 5.1 Remote Control Basics

	TC PIP::Addressograph::port::SOCKET	<p>analyzer with the network port on the rear panel of the network analyzer.</p> <p>For details of the protocol, please refer to:</p> <p>6.1.2.1 LAN Interface</p>
<p>GPIB (IEC/IEEE Interface)</p> <p>Bus</p>	GPIB::primary address[:INSTR]	<p>The controller realizes remote control by connecting the network analyzer with the port on the rear panel of the network analyzer.</p> <p>The bus interface standard IEC 625.1/IEEE 418 is met.</p> <p>For details, please refer to:</p> <p>6.1.2.2 GPIB Interface</p>

Note 1: VISA, that is, virtual instrumentation software architecture, is a set of standard software interface function library. Users can use this function library to control instruments via GPIB, LAN, USB and other interfaces. Users should first install the VISA library on the control computer and use the VISA library to achieve remote instrument control. Please refer to the user manual of the installed VISA library for details.

LAN Interface.....	9 3
GPIB Interface.....	9 4

## 5.1.1.1 LAN Interface

Signal/spectrum analyzers can use RJ45 communication cable (shielded or unshielded category 5 twisted pair) to access 10Mbps/100Mbps/1000Mbps Ethernet for remote control via the control computer in the LAN. For remote control within the LAN, the signal/spectrum analyzer has been installed with the interface adapter and TCP/IP network protocol, as well as the corresponding TCP protocol-based network services.

The S4052 signal/spectrum analyzer network interface adapters have three modes of operation, which are:

- 10 Mbps Ethernet (IEEE802.3);
- 100 Mbps Ethernet (IEEE802.3u);
- 1000Mbps Ethernet (IEEE802.3ab).

The interface adapter automatically matches the appropriate network speed to the link condition. Generally, the cable connecting the signal/spectrum analyzer should not exceed 100 meters in length. For more information about Ethernet, please refer to: <http://www.ieee.org>.

Knowledges about the LAN interface are introduced below:

## 1) IP address

Physical connection of the network should be guaranteed for remote control on the signal/spectrum analyzer via the LAN. Through the menu "local IP" of the signal/spectrum analyzer, set the address to the subnet where the host computer is located. For example, if the IP address of the host computer is 192.168.12.0, the IP address of the signal/spectrum analyzer should be set to 12.XXX, where XXX is a value between 1 and 255.

When establishing a network connection, only the IP address is required. The VISA addressing string is as follows:

TCPIP: : host address: port: : SOCKET

Where:

TCPIP represents the network protocol used;

host address represents the IP address or host name of the instrument, and is used for identifying and controlling the controlled

### 5.1 Remote Control Basics

instrument;

Port identifies the socket port number, and the socket port number of S4052 signal/spectrum analyzer is 5025; SOCKET represents the raw network socket resource class.

Example:

To establish a raw socket connection, use:

TCP/IP::192.1.2.3::5025::SOCKET

## TIPS

### Method of recognizing multiple instruments in the remote control system

If multiple instruments are connected in the network, the individual IP address and related resource string are used to distinguish. The host computer applies its own VISA resource string for instrument identification.

## 2) Socket communication

The TCP/IP protocol connects a signal source over a LAN socket in the network. As a basic method used in computer network programming, the socket allows applications using different hardware and operating systems to communicate over a network. This method allows for two-way communication between the signal/spectrum analyzers and the computers via ports.

As a software class programmed specially, the socket defines the IP address, device port number and other necessary information for network communication, and integrates some basic operations in network programming. Sockets can be used after installing packaged libraries in the operating system. Two commonly used socket libraries are the Berkeley socket library for UNIX the Winsock library for Windows.

Sockets in the signal/spectrum analyzer are compatible with Berkeley socket and Winsock through application programming interfaces (APIs). In addition, it is compatible with the API of other standard sockets. When SCPIs are used to control the signal/spectrum analyzer, the socket program established in the program issues the command. The socket port number of signal/spectrum analyzer is 5025.

### 5.1.1.2 GPIB Interface

GPIB is the only bus designed specifically for instrument control and is still widely used in automated test systems. The S4052 signal/spectrum analyzer integrates GPIB interface on the rear panel. In order to realize remote control, the host computer should be firstly equipped with GPIB bus card, driver and VISA library. During communication, the host computer addresses the controlled instrument via GPIB address, and the user can change the GPIB address of the controlled instrument to prevent communication failure caused by address conflict in the whole system.

GPIB and its associated interface are defined and described in detail in ANSI/IEEE 488.1-1987 and ANSI/IEEE 488.2-1992. For details of the standards, please refer to the IEEE website: <http://www.ieee.org/> <http://www.ieee.org>.

The following points need to be noted when connecting GPIB:

The test system through GPIB bus components contains up to 15 devices;

The total length of the transmission cable should not be more than 20 m or twice the number of instruments in the system;

In general, the maximum length of the transmission cable between the devices shall not exceed 2 m;

If multiple instruments are connected in parallel, a "live" cable is required;

The end of the IEC bus cable shall be connected to the instrument or master computer.

### 5.1.2 Message

The messages transmitted on the data cable are divided into the following two categories:

**1) Interface message**

Interface messages are GPIB bus-specific messages, and only instruments with GPIB bus functionality respond to interface messages. When the host computer sends an interface message to the instrument, the attention cable should be pulled down first, and then the interface message will be transmitted to the instrument through the data cable.

**2) Instrument message**

For the detailed structure and syntax of the instrument message, see Section "5.1.4 SCPI command". The network analyzer message can be divided into two types as per the transmission direction, namely, command and instrument response. Unless otherwise stated, all remote control interfaces apply instrument message in the same way.

**a) Commands:**

Commands (programming messages) are messages sent by the host computer to the network analyzer for remote control of instrument functions and query of state information. Commands are divided into the following two categories:

Based on the impact on the network analyzer:

- setting commands: change the set state of the instrument, such as reset or setting frequency.
- query commands: query and return data, for example: identify the instrument or query the parameter value. Query commands end with the suffix question mark.

Based on the definition in the standard:

- common commands: function and syntax defined by IEEE488.2 for all types of instruments (if implemented) used to implement: management of standard status registers, reset and self-test, etc.
- instrument control commands: instrument characteristic commands, used to realize instrument functions, such as setting frequency. The syntax also follows the specifications of SCPI.

**b) Instrument responses:**

Instrument responses (response message and service request) are the query result information sent by the instrument to the computer. Such information includes measurement results, instrument status, etc.

**5.1.3 SCPI**

Introduction to SCPI .....	9 5
Description of SCPI .....	9 6

**5.1.3.1 Introduction to SCPI Command**

SCPI (Standard Commands for Programmable Instruments) are a command set for all instruments established based on Standard IEEE488.2. The main purpose is to make the same function have the same program command to achieve the universality of remote control commands.

SCPI consist of a command header and one or more parameters. The command header is separated from the parameters by spaces and contains one or more key fields. A command with direct suffix question mark is a query command. Commands are divided into common commands and instrument commands that have different syntactic structures. SCPI have the following characteristics:

- 1) Programmed control commands are oriented to test function rather than describing instrument operation;
- 2) Programmed control commands reduce the repetition of similar test function realization process, and ensure the compatibility of programming.
- 3) Programmed control messages are defined in layers that are hardware independent of the communication physical layer;
- 4) Programmed control commands are independent of programming methods and languages. The test program of SCPI is easy to transplant.

**5.1 Remote Control Basics**

- 5) Programmed control commands are scalable and can adapt to different scale of measurement control;
- 6) SCPI have been a "living" standard for their scalability.

If you are interested in learning more about SCPI, please refer to:

IEEE Standard 488.1-1987, IEEE Standard Digital Interface for Programmable Instrumentation. New York, NY, 1998.

IEEE Standard 488.2--1987, IEEE Standard Codes, Formats, Protocols and Comment Commands for Use with ANSI/IEEE Std488.1-1987. New York, NY, 1998.

Standard Commands for Programmable Instruments(SCPI) VERSION 1999.0.

For programmed control command set, classification and description of S4052 signal/spectrum analyzer, please refer to:

- 1) "Annex B Zoom table of SCPI commands" of the Manual;
- 2) Programmed Control Manual "3 Programmed Control Commands";
- 3) Programmed Control Manual 6.1 Annex A SCPI Command Tree.
- 4) "6.2 Annex B Zoom table of SCPI commands classified as per subsystems" of the Programmed Control Manual;
- 5) "6.3 Annex C Zoom table of SCPI commands classified as per menus" of the Programmed Control Manual.

**5.1.3.2 Description of SCPI**

General Terms .....	9 6
Command Type .....	9 7
Instrument Command Syntax .....	9 7
Command Tree.....	9 8
Command Parameters and Responses .....	9 8
Number System of Commands .....	1 0 1
Command Line Structure .....	1 0 2

**1) General terms**

The following terms apply to this section. To better understand the chapters, you shall understand the exact definitions of the terms.

**a) Controller**

A controller is any computer used to communicate with the SCPI device. A controller may be a PC, minicomputer, or a plug-in card on a cage. Some AI devices can also be used as controllers.

**b) Device**

A device is any device that supports SCPI. Most of the devices are electronic measurement or excitation devices that use GPIB interfaces for communication.

**c) Program message**

A program message is the combination of one or more SCPI commands that have been correctly formatted. Program messages tell the devices how to measure and output the signals.

**d) Response message**

A response message is a set of data of specified SCPI formats. Response messages always come from the devices to controllers or listening devices. Response messages tell the controllers about the internal state or measured values of the devices.

**e) Command**

A command is an instruction that satisfies the SCPI standard. The combination of commands controlling the devices forms a message. In general, a command includes keywords, parameters, and punctuation.

**f) Event command**

Event-type remote control commands cannot be queried. An event command generally has no corresponding front panel key setting, and its function is to trigger an event at a specific time.

**g) Query**

A query is a special type of command. When a control device is queried, a response message appropriate to the controller syntax requirements is returned. A query statement always ends with a question mark.

**2) Command type**

There are two types of SCPI: common commands and instrument commands. Common commands, defined by IEEE 488.2, are used to manage macros and status registers and for synchronization and data storage. Because common commands all start with an asterisk, they are easy to be recognized. For example, \*IDN?, \*OPC, \*RST are all common commands. Common commands are not part of any instrument commands, and the instrument interprets them in the same way regardless of the current path setting of the commands.

Instrument commands are easy to be recognized because they contain a colon (:). A colon is used in the beginning of an expression or between two keywords, for example: FREQUency[:CW? ]. According to the internal function module of the instrument, instrument commands are divided into sub-sets of corresponding subsystem commands. For example, the power subsystem (:POWer) contains power-related commands, while the status subsystem (:STATus) contains commands for the status control register.

**3) Instrument Command Syntax**

Table 5.2 Special characters in command syntax

Symbol	Meaning	Example
	The vertical bar between the keyword and the parameter represents multiple options.	[:SOURce]:AM: SOURce EXTernal INTernal EXTernal and INTernal are optional
[]	Square brackets indicate that the keyword or parameter contained is optional when constructing the command. The command will also be executed even if these implied keywords or parameters are ignored.	[:SOURce]:AM[:DEPTH]:EXPon ential? SOURce and DEPTH are optional.
< >	The contents in the angle brackets indicate that the command is not used literally. They represent the part that must be contained.	[:SOURce]:FREQ:STOP <val><unit> In this command, <val> and <unit> must be replaced with actual frequency and unit. For example: :FREQ:STOP 3.5GHz
{ }	The part in braces indicates that the parameter is optional.	[:SOURce]:LIST:POWer <val>{,<val>} For example: LIST:POWer 5

Table 5.3 Command syntax

Characters, keywords and syntax	Example
---------------------------------	---------

### 5.1 Remote Control Basics

Uppercase characters represent the minimum set of characters required to execute a command.	<code>[:SOURce]:FREQuency[:CW]?</code> FREQ is the short format part of the command.
Lowercase character of the command is optional; such flexible format is called "flexible listening". See the section "Parameters and Responses of Commands" for more information.	<code>:FREQuency</code> <code>:FREQ,:FREQuency</code> or or <code>:FREQUENCY</code> Either of them is correct.
When a colon is between the two command mnemonics, it moves the current path in the command tree down by one level. For more information, please refer to the command path part in section "Command Tree".	<code>:TRIGger:OUTPut:POLarity?</code> TRIGger is the topmost keyword of this command.
If the command contains more than one parameter, adjacent parameters are separated. The parameter is not part of the command path, so it does not affect the path layer.	<code>[:SOURce]:LIST:DWELI &lt;val&gt;{&lt;val&gt;}</code>
The semicolon is used to separate 2 adjacent commands, without affecting current command path.	<code>:FREQ 2.5GHZ; :POW 10DBM</code>
Blank characters, such as <space> or <tab>, are usually ignored as long as they do not appear between keywords or in keywords. However, you must separate the commands and parameters with blank characters, which does not affect the current path.	<code>:FREQ uency</code> or <code>:POWer :LEVel6.2</code> is not allowed. <code>:LEVel</code> and <code>6.2</code> must be separated by a space, namely, <code>:POWer:LEVel 6.2</code> .

A typical command consists of a keyword prefixed with a colon. The keyword is followed by parameters. The following is an example of a syntax declaration:

```
[:SOURce]:POWer[:LEVel] MAXimum|MINimum
```

In the example above, the `[:LEVel]` in the command follow `:POWer` closely without any space. `MINimum|MAXimum` immediately following `[:LEVel]` is the parameter. There is a space between the command and the parameter. Other parts of the syntax expression are described in Table 5.2 and Table 5.3.

#### 4) Command tree

Most remote control programs apply instrument commands. When parsing such commands, SCPI apply a file system-like structure called command tree.

The top command is the root command, or "root" for short. When a command is parsed, follow a specific path to the next level of command according to the tree structure. For example, in `:POWer:ALC:SOURce?`, `:POWer` stands for AA, `:ALC` stands for BB, `:SOURce` stands for GG, and the entire command path is `(:AA:BB:GG)`.

A software module in instrument software - command interpreter, is responsible for parsing each received SCPI. The command interpreter breaks commands into individual command elements by using a series of rules that distinguish the path of the command tree. After parsing the current command, keep the current command path unchanged. The advantage of this is to parse subsequent commands more quickly and efficiently since that the same command keyword may appear in different paths. After booting or \*RST (resetting) the instrument, current command path is reset to root.

#### 5) Command parameters and responses

Table 5.4 Parameter and response types of SCPI

Parameter type	Response data type
Numerical	Real number or integer

Extended numerical	Integer
Discrete	Discrete
Boolean	Digital boolean
String	String
Blocks	Finite-length blocks
	Infinite-length blocks
Non-decimal numeric types	Hexadecimal
	Octal
	Binary

SCPI define different data formats in the use of program and response messages to comply with the principles of "**flexible listening**" and "**precise speaking**". For more information, please refer to IEEE488.2. "**Flexible listening**" means that the formats of the commands and parameters are flexible.

For example, the signal/spectrum analyzer sets the frequency offset status command :FREQuency:OFFSet:STATe ON|OFF|1|0.

The following command formats are all used to set the frequency offset function to on:

:FREQuency:OFFSet:STATe ON, :FREQuency:OFFSet:STATe 1,

:FREQ:OFFS:STAT ON , :FREQ:OFFS:STAT 1

Each parameter type has one or more corresponding response data types. During query, a data type will be returned for a numerical parameter, and the response data is precise and strict, known as "**precise speaking**."

For example, during query of the power state (:POWER:ALC:STATe?), when it is ON, the response data returned is always 1 during query, regardless of whether the previously sent setting command is :POWER:ALC:STATe 1 or :POWER:ALC:STATe ON.

#### a) Numerical parameters

Numeric parameters can be used in both instrument-specific commands and common commands. A numeric parameter receives all the usual decimal counting methods, including signs, decimals, and scientific notation. If a device only accepts a specified numeric type, such as an integer, it will automatically round up the received numeric parameters.

Examples of numeric parameters:

0 No decimal point

100 Optional decimal point

1.23 Signed bit

4.56e<space>3 Index mark e can be followed by a space

-7.89E-01 Index marker e can be uppercase or lowercase

+256 Positive lookahead allowed

5 Decimal points can be used first

#### b) Extended numerical parameters

Most measurements related to instrument commands use extended numeric parameters to specify physical quantities. Extended numerical parameters receive all numeric parameters and additional special values. All the extended numeric parameters receive MAXimum and MINimum as parameter values. Whether other special values, such as UP and DOWN, will be received is determined by the ability of the instrument to parse. All effective parameters will be listed in the table of SCPI.

Note: Extended numeric arguments do not apply to common commands or STATus subsystem commands.

Examples of extended numeric parameters:

**5.1 Remote Control Basics**

- 101 Numeric parameter
- 1.2GHz GHz can be used as an index (E009)
- 200MHz MHz can be used as an index (E006)
- 100mV -100 millivolts
- 10DEG 10 degrees
- MAXimum Maximum effective setting
- MINimum Minimum effective setting
- UP Increase by a step
- DOWN Reduce by a step

**c) Discrete parameters**

When the number of parameter values to be set are finite, they are identified by discrete parameters. Discrete parameters use mnemonics to represent each valid setting. Like program command mnemonics, discrete parameter mnemonics have two formats, long and short, and allow for mixture of upper and lower cases.

In the following examples, discrete parameters and commands are used together.

:TRIGger[:SEquence]:SOURce BUS|IMMediate|EXTernal

BUS GPIB, LAN trigger

IMMediate Trigger immediately

EXTernal Trigger externally

**d) Boolean parameters**

A Boolean parameter represents a true or false binary condition, which can only have four possible values.

Boolean parameter examples:

- ON Logically true
- OFF Logically false
- 1 Logically true
- 0 Logically false

**e) String parameters**

String parameters allow ASCII strings to be sent as parameters. Single quotes and double quotes are used as separators.

The following are example of string parameters:

'This is Valid' "This is also Valid" 'SO IS THIS'

**f) Real response data**

Most of the test data are of real number type, and their formats can be basic decimal notation or scientific notation, which are supported by most advanced programming languages.

Examples of real number response data:

- 1.23E+0
- 1.0E+2
- +1.0E+2
- 0.5E+0
- 0.23
- 100.0
- +100.0
- 0.5

**g) Integer response data**

An integer response data is a decimal expression of an integer value containing signed bit. When querying the state register, most of the response data returned are of integer type.

Examples of integer response data:

0	Sign bit optional
+100	Positive lookahead allowed
-100	Negative lookahead allowed
256	No decimal point

**g) Discrete response data**

Discrete response data are basically the same as discrete parameters, only that the return format of discrete response data is only a short form in uppercase.

Examples of discrete response data:

INTernal	Stabilization mode is internal
EXTernal	Stabilization mode is external
MMHead	Stabilization type is millimeter wave source module

**i) Digital Boolean response data**

A binary value 1 or 0 is returned as Boolean response data.

**j) String response data**

String response data and string parameters are alike. The main difference is that the separators of string response data are double quotes instead of single quotes. Double quotes can also be embedded in string response data, and there may be no characters between the double quotes. Here are some examples of string response data:

"This is a string"  
 "one double quote inside brackets: ("")"

**6) Number system of commands**

The value of the command can be entered in binary, decimal, hexadecimal or octal format. When using binary, hexadecimal or octal format, a proper identifier is required before the value. The decimal format (the default format) does not require an identifier. When a value is entered without an identifier in front of it, the device will ensure it to be in decimal format. The following list shows the required representations for each format:

#B indicates that the number is a binary number;  
 #H indicates that the number is a hexadecimal number;  
 #Q indicates that the number is an octal number.

The following are various representations of the decimal number 45 in SCPI:

#B101101  
 #H2D  
 #Q55

The following example sets the RF output power to 10dBm (or a value of the equivalent value of the currently selected unit, such as DBUV or DBUVMF) with a hexadecimal value of 000A.

:POW #H000A

When using a non-decimal format, a measurement unit, such as DBM or mV, is not used with the value.

## 5.1 Remote Control Basics

### 7) Command line structure

A command line may contain multiple SCPI. To indicate the end of the current command line, the following methods may be used:

- Enter;
- Enter and EOI;
- EOI and the last data byte.

Commands on the command line are separated by semicolons, and commands belonging to different subsystems begin with a colon. For example:

```
MMEM:COPY "Test1", "MeasurementXY";:HCOP:ITEM ALL
```

The command line contains two commands: the first one belongs to the MMEM subsystem, and the second belongs to the HCOP subsystem. If adjacent commands belong to the same subsystem with repeated command path, they can be expressed in abbreviation. For example:

```
HCOP:ITEM ALL;:HCOP:IMM
```

The command line contains two commands: both of them belong to the HCOP subsystem, with the same first level. Therefore, the second command can start from the next level of HCOP, and the colon for starting the command can be omitted. It can be abbreviated as follows:

```
HCOP:ITEM ALL;IMM
```

#### 5.1.4 Command Sequence and Synchronization

IEEE488.2 defines the difference between overlapping and sequential commands:

Sequential commands are sequences of commands that are executed continuously. Each command is usually executed faster.

An overlapping command is one that is not executed automatically before the next command is executed. It usually takes longer to process overlapping commands, and programs are allowed to process other events synchronously during the period.

Even if there are multiple setting commands on a command line, they may not be executed in the order they were received. To ensure that commands are executed in a certain order, each command must be sent on a separate command line.

#### **Example: the command line contains setting and query commands**

If multiple commands on a command line contain query commands, the query results are unpredictable. A fixed value is returned for the following command:

```
:FREQ:STAR 1GHZ;SPAN 100;:FREQ:STAR?
```

Returned value: 1000000000 (1GHz)

The following command returns an unfixed value:

```
:FREQ:STAR 1GHZ;STAR?;SPAN 1000000
```

The returned result can be current initial frequency value of the instrument before such command is sent, since the host program will not execute the commands one by one until all command messages are received. If the host program executes after receiving the command, the returned result may also be 1GHz.

## TIPS

### **Setting commands are sent separately from query commands**

General rules: The setting command and query command shall be sent in different program control messages, so as to ensure the returned result of the query command is correct.

### 5.1.4.1 Prevent overlapping execution of commands

In order to prevent overlapping execution of commands, multithreading or commands \*OPC, \*OPC? or \*WAI may be applied, which are executed only after the hardware setting is completed. During programming, the computer may force a period of time to synchronize certain events. The descriptions are shown below:

#### Master program using multi-threading

Multi-threading is used to wait for command completion and synchronization between the UI and program control, that is, to wait for \*OPC? Completion in separate threading without interfering GUI or program threading execution.

The application of the three commands in synchronous execution is shown in the table below:

Table 5.5 Command syntax

Method	Action	Programming method
*OPC	After the command is executed, set it in the operation completion bit of the ESR register.	Set to ESE BIT0; Set to SRE BIT5; Send overlapping commands and *OPC; Wait for service request (SRQ) Service request represents that the overlapping command has been executed.
*OPC?	Stop executing the current command until 1 is returned. The command is returned only when it is in the operation completion bit of the ESR register, indicating that the previous command has been processed.	Terminate processing of the current command before executing other commands, and send the command directly after the current command.
*WAI	Before the execution of *WAI, wait for all commands to be sent before proceeding with unfinished commands.	Terminate the processing of the current command before executing other commands, and send the command directly after the current command.

### 5.1.5 State Reporting System

The status report system stores all operation status information and error information of current instrument. They are stored in status registers and error queues respectively, and can be queried through a remote control interface.

Structure of Status Register .....	1 0 3
Application of Status Reporting System .....	1 0 5

#### 5.1.5.1 Structure of State Register

State registers are described by classification below:

- 1) STB, SRE

The status byte (STB) register and its related mask register - service request enable register (SRE), comprise the top register of the status reporting system. STB saves the general working state of the instrument by collecting the information of lower registers.

- 2) ESR, SCPI status register

STB receives information from the following registers:

The value of the event status register (ESR) and the event status enable (ESE) mask register.

SCPI status register includes: STATus:OPERation and STATus:QUESTionable registers (SCPI definition),

which contain the specific operation information of the instrument. All SCPI status registers have the same internal structure

(For details, see 2.1.5.2 "SCPI status register structure")

5.1 Remote Control Basics

of the program control manual).

3) IST,PPE

Similar with SRQ, IST (“Individual Status”) marks a separate bit consisting of all statuses of the instrument. The associated parallel poll enable register (PPE) determines the STB data bits for IST marking.

4) Output buffer

It stores the messages returned by the network analyzer to the master. It does not belong to the status report system, but determines the MAV position value of the STB.

For details on the registers mentioned above, refer to “2.1.6 State reporting system” of the programmed control manual.

Please refer to the hierarchical structure of status register shown in Figure 5.1.

TIPS

SRE, ESE

SRE may be used as the enable part of STB. Similarly, ESE may be used as the enable part of ESR.

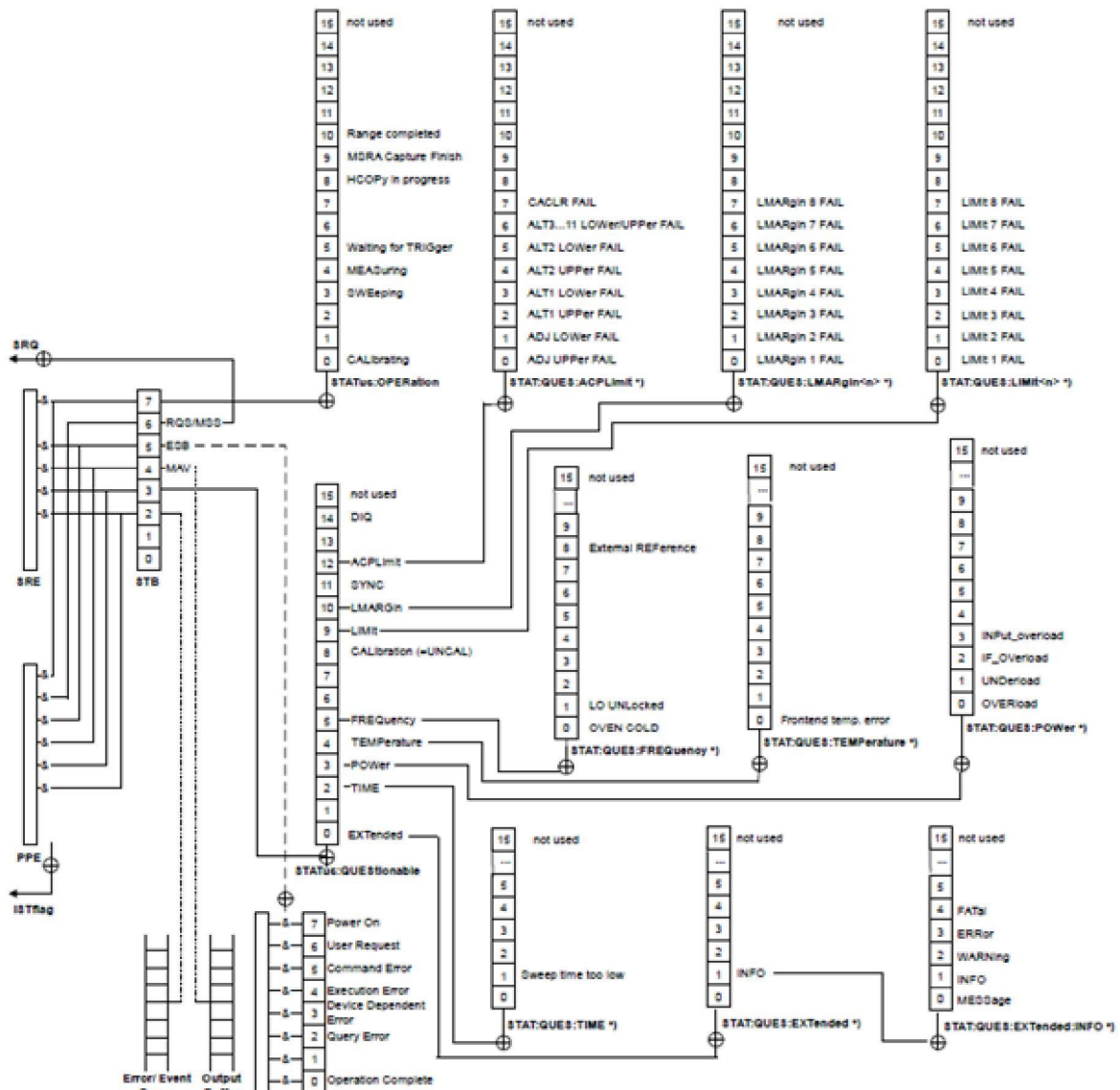

Figure 5.1 Hierarchical structure of the state register

### 5.1.5.2 Application of State Reporting System

The state reporting system is used to monitor the state of one or more instruments in a test system. In order to correctly realize the function of the state reporting system, the controller in the test system must receive and evaluate the information of all instruments.

Standard methods used include:

- 1) Service request (SRQ) initiated by the instrument;
- 2) Serial query of all instruments in the bus system, initiated by the controller in the system, in order to find the initiator of the service request and the reason.
- 3) Parallel query of all instruments;
- 4) Program command to query the status of specific instruments;

For specific operation methods, refer to "2.1.5 Status Report System Application" of the programmed control manual.

### 5.1.6 Programming Precautions

#### 1) Please initialize the instrument status before changing settings

When setting the instrument remotely, first initialize the instrument status (for example, send "\*\*RST"), and then implement the required status setting.

#### 2) Command sequence

In general, setting commands and query commands should be sent separately. Otherwise, the returned value of query commands will change with the current order of instrument operation.

#### 3) Fault response

Service requests can only be initiated by the network analyzer. The controller program in the test system should guide the network analyzer to initiate service request actively when there is an error, and then enter corresponding interrupt service program for processing.

#### 4) Error queue

Each time the controller program processes a service request, it should query the error queue of the network analyzer instead of the state register for a more precise cause of the error. Especially in the test phase of the controller program, the error queue should be frequently queried to obtain the error command sent by the controller to the network analyzer.

## 5.2 Instrument Program Port and Configuration

L A N .....	1 0 5
G P I B .....	1 0 6

### 5.2.1 LAN

SOCKET is used by LAN programmed control system to control S4052 signal/spectrum analyzers.

## NOTICE

### Application of the connector at the master control port of front-panel USB

Type-A connector on the front panel is the connector at the master control port of USB. In S4052 signal/spectrum analyzers, the port is used to connect U disk to realize the upgrade of resident software of the instrument. It may also be connected to the USB keyboard and mouse to control the signal/spectrum analyzer. The port should not be used for program control of the instrument.

**5.3 Basic VISA interface programming**

C o n n e c t i o n   E s t a b l i s h m e n t.....	1 0 6
I n t e r f a c e   C o n f i g u r a t i o n.....	1 0 6

**5.2.1.1 Connection Establishment**

Use a network cable to connect the S4052 signal/spectrum analyzer to a LAN with an external controller (computer). Special attention should be paid to the IP address settings that may cause address conflicts, so please check with your network administrator before setting to prevent conflicts from occurring.

**5.2.1.2 Interface Configuration**

Physical connection of the network should be guaranteed for remote control on the signal/spectrum analyzer via the LAN. Since DHCP, domain name access and WAN connection are not supported, the network programmed control setting of the signal/spectrum analyzer is relatively simple. Click [System]-> [Interface Configuration] -> [Network Configuration] to set "IP Address", "Subnet Mask" and "Default Gateway" through the menu to the subnet where the master controller resides.

In order to make the user network program-controlled S4052 series signal/spectrum analyzer more convenient and more flexible in the use of the port number, the menu for configuring the port number and the program-controlled commands for related settings and querying the port number are added on the software interface. The Port Number Configuration menu is shown in Figure 5.3, with the default port number set to 5025.

The user can modify the port number in two ways:

1. Enter the interface shown in Figure 5.3 via the [System] [Interface Configuration>>] [Port Number Configuration>>] on the front panel, and then press the number keys in the [Port Number Configuration] input box to make changes;
2. Use the SCPI command to set the network port number, and the port number setting valid range is 1024--65535.

The port number takes effect immediately after the user modifies it. If the port number is not changed later, it remains the same as the value set by the user last time. The port number does not change when the user resets or the device status is called, and does not affect interface configurations such as GPIB address and network address.

**NOTICE****Ensure that the signal/spectrum analyzer is physically connected through an RJ45 Ethernet cable**

Since the signal/spectrum analyzer only supports the establishment of a single LAN control system and the setting of static IP address instead of DHCP and host access through DNS and domain name server, users are not required to modify the subnet mask that is set to 255.255.255.0 / by the instrument.

**5.2.2 GPIB**

Users may need to modify the GPIB address when using the signal/spectrum analyzer to establish the system. The default GPIB address of the machine is 28. Methods for modification of the GPIB address are described below:

Press [System] [Interface Configuration] to make changes in the input box of GPIB address of this machine.

**5.3 Basic VISA interface programming**

Take the following as an example to describe the basic method for realizing instrument program control programming via the VISA library. Take the C++ language as an example.

I n s t a l l   V I S A   L i b r a r y.....	1 0 7
I n i t i a l i z e   t h e   C o n t r o l l e r.....	1 0 7

**5.3 Basic VISA interface programming**

Initialize the Instrument.....	1 0 7
Send Setting Command.....	1 0 7
Read the State of Measuring Instrument.....	1 0 8
Read Maker.....	1 0 8
Command Synchronization .....	1 0 8

**5.3.1 Installing VISA Library**

To realize remote control, the VISA library must be installed first. The VISA library is encapsulated with the transmission function at the bottom layer with VXI, GPIB, LAN and USB interfaces, so as to facilitate users' direct loading. The signal/spectrum analyzer supports such programming interfaces as GPIB and LAN. These interfaces can be used with VISA library and programming languages for remote control of signal/spectrum analyzers.

**5.3.2 Initialize Controller**

```
/******
```

The following example shows how to open and establish a communication connection between the VISA library and the instrument (as specified by the instrument descriptor).

```
//Initialize the master: open the default resource manager and return the network analyzer handle analyzer
```

```
/******
```

```
void InitController()
```

```
{
```

```
    ViState state;
```

```
    state = viOpenDefaultRM(&defaultRM);
```

```
    status = viOpen(defaultRM, analyzerString, VI_NULL, VI_NULL, &analyzer);
```

```
}
```

**5.3.3 Initialize the instrument**

```
/******
```

The following example shows how to initialize the default state of the instrument and empty the status register.

```
/******
```

```
void InitDevice()
```

```
{
```

```
    ViState state;
```

```
    long retCnt;
```

```
    status = viWrite(analyzer, "*CLS", 4, &retCnt); //reset status register
```

```
    status = viWrite(analyzer, "*RST", 4, &retCnt); //reset instrument
```

```
    status = viWrite(analyzer, ":INST:SEL SA", 12, &retCnt); //Set instrument operating mode (using signal/spectrum analyzer command as an example)
```

```
}
```

**5.3.4 Send Setting Command**

```
/******
```

The following example shows how to set center frequency of the S4052 series signal/spectrum analyzer.

```
/******
```

```
void SimpleSettings()
```

```
{
```

```
    ViState state;
```

```
    long retCnt;
```

### 5.3 Basic VISA interface programming

```
//Set the center frequency to 128MHz

status = viWrite(analyzer, ":-FREQUENCY:CENTER 128MHz", 22, &retCnt);

}
```

#### 5.3.5 Read the State of Measuring Instrument

```
/*-----*/

The following examples show how to read the set state of the instrument.

/*-----*/

void ReadSettings()
{
    ViState state;
    long retCnt;
    char rd_Buf_CW[VI_READ_BUFLen]; // #define VI_READ_BUFLen 40

    // Query center frequency
    status = viWrite(analyzer, ":-FREQ:CENT?", 10, &retCnt);

    status = viRead(analyzer, rd_Buf_CW, 20, &retCnt);

    //Print debugging information
    sprintf("Cw is %s", rd_Buf_CW);
}

```

#### 5.3.6 Reading Marker (For Signal/Spectrum Analyzer)

```
/*-----*/

The following example shows how to read the marker measurement value.

/*-----*/

void ReadMarker ()
{
    ViState state;
    long retCnt;
    char rd_Buf_Marker[VI_READ_BUFLen]; // #define VI_READ_BUFLen 20

    //Open marker 1 and query marker peak (frequency and amplitude)
    status = viWrite(analyzer, ":-CALC:MARKER:MAX", 25, &retCnt);

    status = viWrite(analyzer, ":-CALC:MARK:Y?", 15, &retCnt);

    //Print debugging information
    sprintf("Marker is %s", rd_Buf_Marker);
}

```

#### 5.3.7 Command Synchronization

```
/*-----*/
```

The following examples illustrate the methods for command synchronization with sweep process.

```

/*****/
void SweepSync()
{
    ViState state;
    long retCnt;
    ViEventType etype;
    ViEvent eevent;
    int stat;
    char OpcOk [2];

    /*****/
    /* The command INITiate[:IMMEDIATE] is used to start single sweep (when continuous sweep is OFF, INIT:CONT OFF)*/
    /* Only at the end of single sweep can the next command in the command buffer be executed */
    /*****/
    status = viWrite(analyzer, ":INIT:CONT OFF", 13, &retCnt);
    //Method 1 for waiting for the sweep to end: use *WAI
    status = viWrite(analyzer, ":INIT", 18, &retCnt);
    status = viWrite(analyzer, "*WAI", 18, &retCnt);

    //Method 2 for waiting for the sweep to end: use *OPC?
    status = viWrite(analyzer, ":INIT", 20, &retCnt);
    status = viWrite(analyzer, "**OPC?", 18, &retCnt);
    status = viRead(analyzer, OpcOk, 2, &retCnt); //wait for *OPC to return "1"

    //Method 3 for waiting for the sweep to end: use *OPC
    //To use the GPIB service request, set "Disable Auto Serial Poll" to "yes"
    status = viWrite(analyzer, "**SRE 32", 7, &retCnt);
    status = viWrite(analyzer, "**ESE 1", 6, &retCnt); //enable service request ESR
    //Set the event enabling position, and end the operation.
    status = viEnableEvent(analyzer, VI_EVENT_SERVICE_REQ, VI_QUEUE, VI_NULL);
    //Enable the SRQ event
    status = viWrite(analyzer, ":INIT ", 18, &retCnt);
    status = viWrite(analyzer, "**OPC", 18, &retCnt);

    //Start sweeping together with OPC
    status = viWaitOnEvent(analyzer, VI_EVENT_SERVICE_REQ, 10000, &etype, &eevent)
    //Wait for service request
    state = viReadSTB(analyzer, &stat);
    state = viClose(eevent); //close event handle
    //Disable SRQ event
    status = viDisableEvent(analyzer, VI_EVENT_SERVICE_REQ, VI_QUEUE);
    //Main program continues ... ..
}

```

## 5.4 I/O library

Overview of I/O Library .....	1 0 9
Installation and Configuration of I/O Library .....	1 1 0

### 5.4.1 Overview of I/O Library

I/O library is a pre-written software library for instruments, known as instrument driver. As a software between the computer and the

#### 5.4 I/O library

network analyzer hardware, it consists of the function library, utility program, tool kit, etc. It is a combination of a series of software code modules and corresponds to operation of a plan, such as configuring the network analyzer, reading from the network analyzer, writing to the network analyzer and trigger the network analyzer, etc. Residing in the computer, it is the bridge and link between the computer and the network analyzer. By providing a high-level modular library for convenient programming, users no longer need to learn the complex low-level programming protocol for a specific instrument. Application of instrument driver is the key to develop test and measurement applications quickly.

Functionally, a universal instrument driver generally consists of five parts: functor, interactive developer interface, programmer interface, subprogram interface and I/O interface, as shown in Figure 5.2.

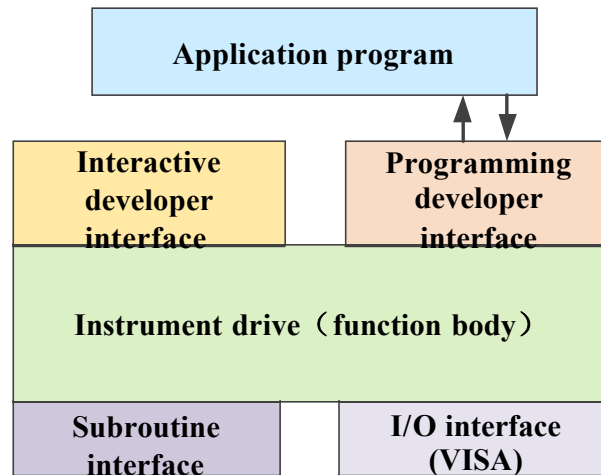

Figure 5.2 Structure model of instrument driver

The details are as follows:

- 1) Functor. As the main function part of the instrument driver, it may be understood as its framework program.
- 2) Interactive developer interface. Application development environment that supports instrument driver development is usually provided with graphical interactive developer interface for user convenience. For example, in Labwindows/CVI, the function panel is an interactive developer interface. In the function panel, each parameter of the instrument driver function is represented as a graphical control.
- 3) Programmer interface. It is a software interface for the application to call instrument driver function, such as dynamic link library file.dll of instrument driver in Windows system.
- 4) I/O interface. It completes the actual communication between the instrument driver and the instrument. The bus-specific I/O software (such as GPIB) or the generally-standardized I/O software applied cross multiple buses (VISA I/O) can be used.
- 5) Subprogram interface. It is a software interface for the instrument driver to access other support libraries, such as databases, FFT functions, etc. The subprogram interface is used when the instrument driver needs to call other software modules, operating systems, program code libraries and analysis function libraries to complete its task.

#### 5.4.2 Installation and configuration of I/O library

Along with the application in test field, it has gone through different development stages from traditional instrument to virtual instrument. In order to solve the interchangeability of instruments and reusability of test program in automatic test system, instrument driver has gone through different development processes. IVI (Interchangeable Virtual Instruments) driver is relative popular and common at present. Based on IVI specification, it defines a new instrument programming interface, inserts the class driver and VPP architecture onto the VISA to make the test application and instrument hardware completely independent, adds such unique functions as instrument simulation, range sensing and status cache, improves the operation efficiency of the system, and realizes instrument exchange.

There are two types of IVI driver: IVI-C and IVI-COM, where the latter adopts the form of COM API based on the component object

model (COM) of Microsoft, and the former adopts the form of C API based on ANSI C. Both types are designed according to the instrument class defined in the IVI specification and have the same application development environment, including Visual Studio, Visual Basic, Agilent VEE, LabVIEW, CVI/LabWindows, etc.

Two types of driver should be provided at present to meet the needs of different users in different development environments. IVI driver of the signal/spectrum analyzer is developed with Nimbus Driver Studio and directly generates IVI- COM and IVI-C driver and program installation package. For specific installation and configuration, please refer to the attached documentation of the control card and I/O library you selected.

IVI driver after installation are divided into IVI inherent function group and instrument function group (basic function group and extended function group). Specific function classification, functions and attributes are shown in the help document of the driver.

---

## TIPS

### **Port configuration and IO library installation**

Before using a computer controlled signal/spectrum network analyzer, please verify that you have properly installed and configured necessary ports and I/O libraries.

---

6.1 Working Principles

## 6 Troubleshooting and after-sales services

This chapter will show you how to find problems and accept after-sales service, It also indicates the error information of the signal/spectrum analyzer.

If you encounter any problem when operating the S4052 series signal/spectrum analyzer or you want to buy its relevant components or accessories, we can provide you with complete after-sales services.

Generally, causes of problems include hardware, software or user maloperation. In case of any problem, please contact us in time. If the signal/spectrum analyzer you purchased is still under warranty, we will repair your spectrum analyzer free of charge as promised in the warranty; Otherwise, we will only charge the cost.

Working Principles.....	112
Troubleshooting and debugging.....	112
Errors .....	119
Method to Obtain After-sales Service.....	120

### 6.1 Working Principles

The section introduces the basic working principle and hardware function block diagram of the S4052 series signal/spectrum analyzer, so as to facilitate users' understanding on functions of the signal/spectrum analyzer and solving problems encountered during operation.

Block Diagram of Working Principle and Hardware Principle of the Machine .....	112
--	-----

#### 6.1.1 Overall working principle and hardware function block diagram

The S4052 series signal/spectrum analyzer is a microprocessor-controlled, linux-operated, triple-conversion, ultra-aberrant swept-spectrum signal/spectrum analyzer. It consists of a microwave receiving module, an RF processing module, a synthetic LO module, a data acquisition and processing module, a DSP processing module, a control display module and a power module. The block diagram of the machine principle is shown in Figure 6.1.

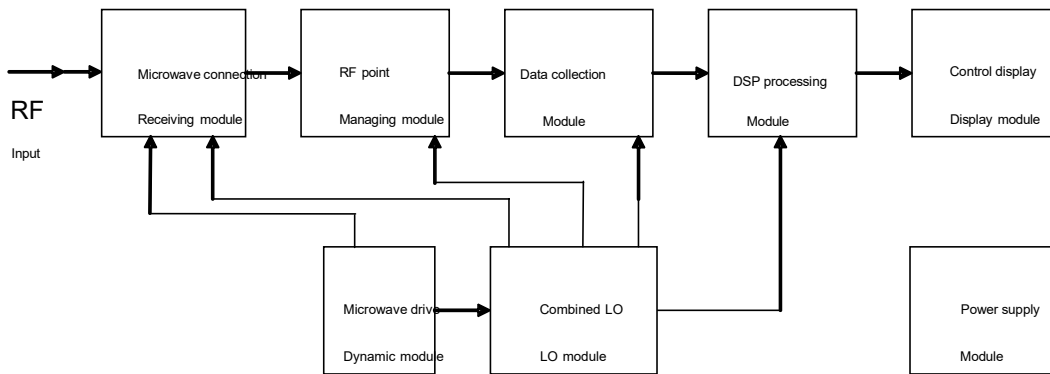

Figure 6.1 Principle block diagram of S4052 series signal/spectrum analyzer

A block diagram of the inverter principle for the microwave millimeter wave path is shown in Figure 6.2.

In the 0-band, the signals of 2Hz~8GHz are sequentially fed into the low band frequency conversion module through a 14dB switch isolated programmable stepper attenuator, 58dB programmable stepper attenuator, duplexer, and mixed with the signal of the first local oscillator (YIG oscillator) (5.225-9.325GHz) to obtain a 5.225GHz IF. After passing through a 5.225GHz bandpass filter, they are fed into the second frequency converter in the low band frequency converter assembly to obtain the difference between the 4.8GHz frequency of the second local oscillator and the 4.25MHz IF.

The high band is divided into 5 bands, namely 1, 2, 3, 4, and 5.

The signals of 8~50GHz are sequentially fed through a 14dB switch isolated programmable stepper attenuator, a 58dB programmable stepper attenuator, a duplexer, a millimeter wave coaxial switch (preselector bypass - option), a millimeter wave YTF, a millimeter wave low noise amplifier, or in broadband mode without YTF or preselector bypass YTF, and then mixed with the first local oscillator signal in the embedded millimeter wave mixer in the local oscillator mixing module to obtain the second IF.

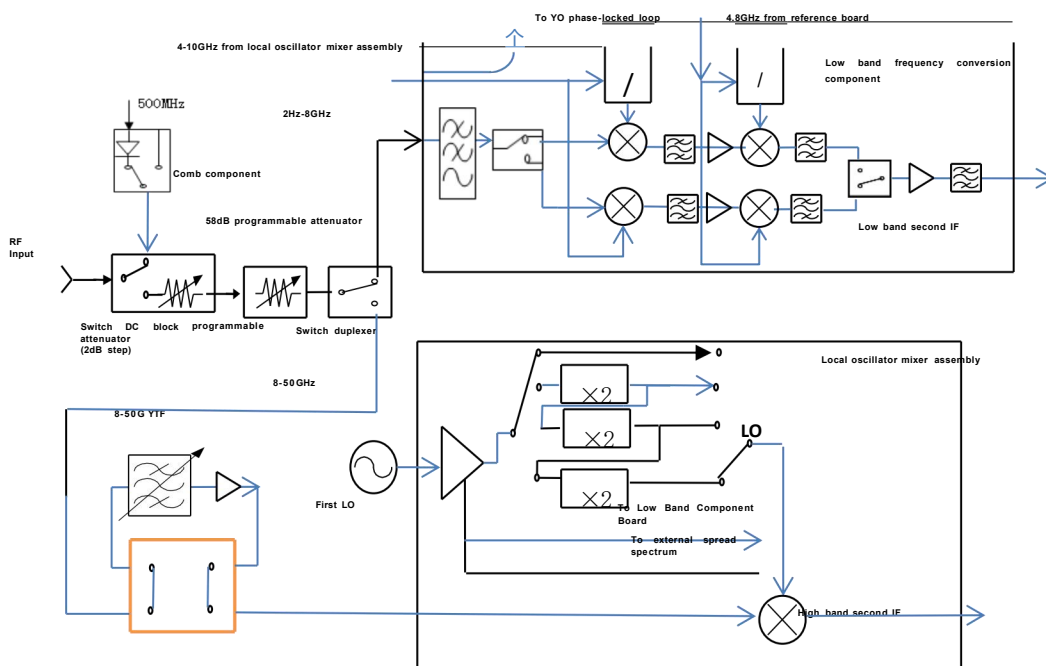

Figure 6.2 Block diagram of inverter principle for microwave millimeter wave path

## 6.2 Troubleshooting

The narrowband acquisition board quantifies the 75MHz IF signal with a bandwidth of 40MHz at a rate of 100MHz. The FPGA on the board can perform digital down conversion and IQ data separation to complete the storage of IQ data.

The main controller controls the internal operation of the signal/spectrum analyzer, and receives various requests from the front panel keyboard or external computer through the I/O port. The control program stored in the flash memory card determines the functions performed by the main controller. The main controller provides control signals to microwave components such as YTO, YTF, programmable step attenuators, and RF switches through a microwave drive board.

## 6.2 Troubleshooting

Under normal circumstances, the problem with the instrument is due to hardware, software, or improper use of users. Once a problem occurs, first observe the error message and save it. Then, analyze the possible causes and refer to the methods provided in section 6.2.1 "Basic Troubleshooting Process" and section 6.2.2 "Common Fault Symptoms and Debugging Methods" to check and solve the problem in advance. You can also contact our service center and provide the error messages you've collected, and we will coordinate with you to solve the problem as soon as possible. Please refer to the contact information provided in this manual or online at [www.saluki.com](http://www.saluki.com) for the nearest technical support contact.

### TIPS

#### Troubleshooting and instructions

This section introduces the way on how to judge and handle failures (if any) of the S4052 series signal/spectrum analyzer, and feed them back to the manufacturer as accurately as possible if necessary for quick solution.

### 6.2.1 Basic Troubleshooting Process

When there is a problem with the instrument, first check the following:

Check whether the power socket has electrical power.

Check whether the signal/spectrum analyzer is enabled. Check whether the white light of the power switch is on. Pay attention to the internal fan noise to determine whether the analyzer's cooling fan is running.

If other instruments, cables and connectors are used with the signal/spectrum analyzer, make sure they are connected and working properly.

If the signal/spectrum analyzer cannot communicate via a LAN, check the yellow LED next to the LAN interface on the rear panel.

If the LED does not flash, check the LAN cables and connections.

If the signal/spectrum analyzer does not fully load nor run the operating system, or the instrument application does not start successfully, the hard disk may be damaged.

If the problem occurs for the first time, check the measurement steps executed. Check whether all settings are correct.

If the analyzer is not functioning properly, press Reset to return the signal/spectrum analyzer to a known state.

Are the measurements performed and their results consistent with the performance indicators and characteristics of the signal/spectrum analyzer? Please refer to the relevant performance indicator data in Chapter "7 Technical Indicators and Test

Methods" of the Signal/Spectrum Analyzer User's Manual.

To meet the indicators of the signal/spectrum analyzer, the signal/spectrum analyzer must be calibrated. (Press [System], [Calibrate], [Calibrate RF]).

Does the instrument display an error message? If there is an error message, please refer to section 6.3 "Errors" in this manual.

## 6.2.2 Common Faults and Troubleshooting Method

The following lists the common faults and troubleshooting methods as per function types.

Problems During Startup.....	1 1 5
Instrument Setup Problems.....	1 1 7
No Signal Display.....	1 1 7
Signal Frequency Reading Exception.....	1 1 7
Signal Amplitude Reading Exception.....	1 1 8
Instrument Cannot Access the Internet .....	1 1 8

### 6.2.2.1 Problems During Startup

If the S4052 series signal/spectrum analyzer fails during startup, it may involve multiple aspects such as the power supply, processor hardware, and instrument setup. This section helps to analyze the possible failures in the startup process and the causes according to the power-on startup steps of the S4052 series signal/spectrum analyzer. The total startup time of the instrument is approximately 3 minutes. The startup time varies slightly depending on the hardware configuration of the instrument, the installation options and the number of measuring applications.

#### 1) Orange standby lamp not on

Power on the instrument power socket and turn on the power switch on the rear panel. The power key in the upper right corner of the instrument screen will turn orange. If the orange standby light is not lit, first check whether the power switch on the rear panel of the signal/spectrum analyzer is on, and then make sure that the voltage and frequency values of the applied power supply meet the working power supply parameter requirements of the S4052 series signal/spectrum analyzer. For details about the requirements, refer to section 3.1.1.3 "Power ON/OFF" in this manual. If the power supply parameters used meet the requirements, it may be due to a malfunction in the instrument power supply. Please contact our service center according to the contact information provided in this manual and provide the error messages you've collected, and we will help solve the problem as quickly as possible.

#### 2) Abnormal white start light

Turn on the instrument by pressing the power key in the upper right corner of the screen. At this point, the power key of the instrument should change from orange to white. If the power key does not turn white, it may be due to a malfunction in the instrument power supply. If the power key flashes alternately in the orange standby and white start states, it, excluding the cause of the power supply, may be abnormal internal load of the instrument. Please contact our service center according to the contact information provided in this manual and provide the error messages you've collected, and we will help solve the problem as quickly as possible.

## 6.2 Troubleshooting

### 3) Abnormal fan

After the S4052 series signal/spectrum analyzer is powered on, all fans of the instrument should start working. If all fans are not working, the power supply of the instrument may be faulty; if an individual fan is not working, the fan is faulty. Please contact our service center according to the contact information provided in this manual and provide the error messages you've collected, and we will help solve the problem as quickly as possible.

### 4) Blank screen

There may be multiple reasons for the problem that the screen is not displayed. If the three situations above have been eliminated, please follow the steps below:

- a) Properly connect a DP display device from the monitor interface of the rear panel of the instrument and turn it on. Wait 30 seconds.  
If the DP displays information properly, the BIOS configuration parameters may be changed. You need to shut down the instrument, connect it to a standard keyboard, and start it up. Press and hold "DEL" to enter the BIOS settings interface. Choose Load Settings Defaults from Exit to call the factory settings for display control in the BIOS, save them, exit, and restart the instrument. If the instrument interface is still not displayed, it may be caused by LCD of the instrument. Please contact our service center according to the contact information provided in this manual and provide the error messages you've collected, and we will help solve the problem as quickly as possible.
- b) If there is still no display after connecting to the DP device for processing, it may be due to a hardware malfunction of the instrument. Please contact the customer service center according to the contact information provided in this manual and provide the collected error information. We will assist you in resolving the problem as soon as possible.

### 5) BIOS Detection Crashing

If the signal/spectrum analyzer keeps displaying the processor information after being powered on, the BIOS detection crashes. Please follow the steps listed below:

- a) Check whether the user has connected to the standard keyboard and suspended the BIOS detection. If not, go to the next step.
- b) Shut down the instrument, connect it to standard keyboard, and start it up. Press and hold "DEL" until entering the BIOS setup interface, select the Load Setup Defaults option in the Exit tab, call the factory configuration in the BIOS, select Save and Restart, and if the problem persists, it may be due to a hardware malfunction of the instrument. Please contact the customer service center according to the contact information provided in this manual and provide the collected error information. We will assist you in solving the problem as quickly as possible.

### 6) System disk not found

If the signal/spectrum analyzer shows that the system cannot find the hard disk after power-on, please turn off the power switch on the back of the signal/spectrum analyzer, wait 1 to 2 minutes, turn it on, and then turn on the power button on the front panel of the signal/spectrum analyzer. Check whether the system disk can be found correctly. If you still cannot find it, add a keyboard to enter the BIOS to check if the storage device is present. If it is not, it may be due to a malfunction in the hard drive of the instrument. Please contact the customer service center according to the contact information provided in this manual and provide the collected error information. We will

assist you in resolving the problem as soon as possible.

### 6.2.2.2 Instrument Setup Problems

When the S4052 series signal/spectrum analyzer enters the test interface and successfully completes all the power-on calibration operations, it enters the normal sweep test state and displays the continuously refreshed trace on the interface. When some parameters of the instrument are improperly set, users may not be able to see the desired trajectory or signal. In case of problems of trace refresh or signal display, please check the following settings first.

#### 1) Trace not refreshed or refreshed abnormally

If the trace on the interface does not refresh, or does not refresh properly, please refer to the following steps:

- a) Check if the trigger setting is in Free Trigger mode, and if the sweep mode is in continuous mode. If the setting is correct and the trace still does not refresh, please proceed to the next step.
- b) Turn on the marker and see if the marker reading changes. If there is a change in the marker reading, it may be due to setting reasons, such as the instrument being set to a linear state or the reference level being too high, causing the trace to be at the bottom of the screen, and thus not visible. In this case, the state can be changed to logarithmic, or the reference level can be reduced to observe the trace again. If the mark reading remains unchanged, it may be due to an error in trace feedback. Please try restarting the machine. If the fault still cannot be eliminated, please contact the customer service center according to the contact information provided in this manual and provide the collected error information. We will assist you in resolving the problem as soon as possible.

#### 2) No signal display

If there is no signal display in all bands, please check as follows: press [Input/Output], [Input Port RF Calibration] to see if an RF signal is selected. If not, select it to the RF port. If there is still no signal display, the signal/spectrum analyzer hardware circuit may be faulty. Please contact the customer service center according to the contact information provided in this manual and provide the collected error information. We will assist you in resolving the problem as soon as possible.

### 6.2.2.3 Signal Frequency Reading Exception

If the signal is found to be moving from side to side on the screen of the signal/spectrum analyzer or the frequency reading is out of the error range during signal measurement, first check whether the frequency of the input signal/spectrum analyzer is stable. If the frequency of the input signal is stable, check whether the reference of the signal/spectrum analyzer is set up correctly. Choose the internal or external reference according to different test cases. To be specific, press [Input/Output], [Frequency Reference Internal External]. If the frequency reading is still not correct, the internal LO of the signal/spectrum analyzer may have lost lock. Please contact the customer service center according to the contact information provided in this manual and provide the collected error information. We will assist you in resolving the problem as soon as possible.

Usually, LO loss of lock includes the following types: Loss of lock when the span is  $\leq 180\text{kHz}$ ; Loss of lock when  $180\text{kHz} < \text{span} \leq 2\text{MHz}$ ; Loss of lock when  $2\text{MHz} < \text{span} \leq 20\text{MHz}$ ; Loss of lock when  $\text{span} > 20\text{MHz}$ ; and the signal only loses lock at certain frequency points, etc.

## 6.2 Troubleshooting

### 6.2.2.4 Signal Amplitude Reading Exception

Amplitude anomalies may occur in the following situations: abnormal low-band reading and normal high-band reading, abnormal high-band reading and normal low-band reading, abnormal full-band reading, and very big reading difference for different signal amplitudes set by the attenuator. If the signal amplitude reading is not accurate, calibrate all IFs of the instrument. If it is still not correct after calibration, the internal circuit of the signal/spectrum analyzer may have problems. Please perform the following steps:

- a) Choose Input/Output > Input Port of RF Calibration > Calibration Port > 500 MHz to start the instrument to calibrate 500 MHz signals.

Set the center frequency to 500 MHz and bandwidth to 1 MHz for the instrument. Enable the peak search function to measure the level of the instrument 500 MHz calibration signal. If the signal/spectrum analyzer is functioning normally, the calibration range should be  $-20 \text{ dBm} \pm 2 \text{ dB}$ . If the amplitude of the calibration signal is not correct, the low-band reading less than 4 GHz of the instrument is abnormal.

- b) Choose Input/Output > Input Port of RF Calibration > Calibration Port > 4.8 GHz to start the instrument to calibrate 4.8 GHz signals.

Set the center frequency to 4.8 GHz and bandwidth to 1 MHz for the instrument. Enable the peak search function to measure the level of the instrument 4.8 GHz calibration signal. If the signal/spectrum analyzer is functioning normally, the calibration range should be  $-20 \text{ dBm} \pm 2 \text{ dB}$ . If the amplitude of the calibration signal is not correct, the band reading of the instrument 4GHz~8GHz is abnormal.

- c) Choose Input/Output > Input Port of RF Calibration > Calibration Port > 9.6 GHz to start the instrument to calibrate 9.6 GHz signals.

Set the center frequency to 9.6 GHz and bandwidth to 1 MHz for the instrument. Enable the peak search function to measure the level of the instrument 9.6 GHz calibration signal. If the signal/spectrum analyzer is functioning normally, the calibration range should be  $-20 \text{ dBm} \pm 2 \text{ dB}$ . If the amplitude of the calibration signal is not correct, the high-band reading greater than 8 GHz of the instrument is abnormal.

Through the above three steps, it can be determined whether the instrument has abnormal readings in the entire band or in some bands. Please contact the customer service center according to the contact information provided in this manual and provide the collected error information. We will assist you in resolving the problem as soon as possible.

---

## NOTICE

Even if the amplitude of the calibration signal (500MHz, 4.8GHz or 9.6 GHz) is normal, the amplitude of the signal in other bands may have problems. The amplitude test with internal calibration signals only provides a quick channel detection.

---

### 6.2.2.5 Instrument cannot access the Internet

- 1) Firstly, ensure that the network supports Internet access.
- 2) Ensure that the appropriate IP settings are obtained from the system administrator.
- 3) Check if the network cable connected to the instrument network interface is intact.

Check whether the access network cable is plugged into the LAN interface on the rear panel of the signal/spectrum analyzer, and whether the orange light flashes at the interface. If no network is accessible, contact our service center according to the contact information

provided in this manual and provide the error messages you've collected, and we will help solve the problem as quickly as possible.

## 6.3 Error Message

The signal/spectrum analyzer records errors during measurement in two ways: error message queues displayed on the front panel and SCPI (in the remote control mode) error message queues, which are stored and managed separately.

Error Message Description.....	1 1 9
--------------------------------	-------

### 6.3.1 Error message Description

Local Error.....	1 1 9
Programmed Control Error .....	1 1 9

#### 6.3.1.1 Local Error Message

Error Message View.....	1 1 9
Error Message Description.....	1 1 9

#### 1) Error message viewing

View via interface operation:

If an error message is displayed on the lower right corner of the signal/spectrum analyzer during the use, the system running or hardware of the signal/spectrum analyzer is faulty. You can basically judge the error type as per the error code, and take corresponding measures for troubleshooting.

Only one error message can be displayed in the signal/spectrum analyzer error display area at a time. Since multiple errors can occur to the network analyzer, to see all errors, do the following:

- Step 1 .Press System and then Error List. The Error List window will pop up.
- Step 2. The prompt will be displayed in the window.
- Step 3:** Use the mouse to browse the error message and close the dialog window.
- Step 4. Select "Clear error list" to clear historical error message.

#### 2) Error message description

If an error is detected during the measurement of the signal/spectrum analyzer, an alarm or error message (error code + error abbreviation) will be displayed on the right side of the status indication area, as shown in Figure 6.3:



Figure 6.3 Error message in the status indication area

For details about local errors, please refer to [Annex C "Zoom table of error information."](#)

#### 6.3.1.2 Program control error message

Error Message Format and Description.....	1 2 0
Error Message Type.....	1 2 0

## 6.4 Method to Obtain After-sales Services

### 1) Error message formats and descriptions

In remote control mode, errors are recorded in the error/event queue of the status reporting system, and can be queried with the command "SYSTem:ERRor?". The format is as follows:

"<Error code>, "<Error in error queue>; <"Detailed error description>"

**Example:**

"-110," a data breaking bounds; the input parameter is beyond the lower bound.

The program control error message includes two types:

A negative error code defined by the SCPI standard. This type of error is not specified here;

A positive error code of instrument characteristics. For description about local errors, please refer to [Annex C "Zoom table of error information."](#)

### 2) Error message types

Error event corresponds to only one type of error message. The types of error messages are classified below (8257):

System error (0–99): control platform, OS, file system, etc.

LO/Front-end channel (100–199): lock detection, state detection, LO, microwave drive, RF board initialization, etc.

Channel calibration (200–299): calibration of bandwidth, gain, attenuation, compensation, etc.

Digital processing module (300–499): initialization of THE narrowband board, broadband board, DSP board, etc., and data acquisition synchronization exception.

Additional modules of the platform (500–599): such as initialization and related anomalies of additional modules of monitoring receivers, EMI receivers and measurement receivers.

Communication interface (600–699): network, gpib, printing, etc.

Processing error (700–799): parameter decomposition, legalization, autonegotiation, etc.

## 6.4 Method to Obtain After-sales Services

Contact Us .....	1 2 0
Package and Mailing .....	1 2 0

### 6.4.1 Contact us

In case of any failure to the S4052 signal/spectrum analyzer, check and save the error message, analyze possible causes, and refer to the methods provided in “6.2 Troubleshooting and Debugging” for preliminary troubleshooting. Otherwise, you can also contact our service center and provide the error messages you’ve collected, and we will coordinate with you to solve the problem as soon as possible. Check the website: [www.saluki.com](http://www.saluki.com) to find contact information of the local technical team.

**Contact information:**

**Phone number: 0532-86889847**

**Fax: 0532-86889056**

**Email: [eiqd@saluki.com](mailto:eiqd@saluki.com)**

**Postal code: 266555**

**Address: No. 98, Xiangjiang Road, Qingdao Economic & Technological Development Zone, Shandong, China**

### 6.4.2 Package and mailing

In case of any failure to the signal/spectrum analyzer that is difficult to be eliminated, contact us by phone or fax. If it is confirmed that the signal/spectrum analyzer has to be returned for repairing, pack it with the original packing materials and case by following the steps

below:

- 1) Prepare a detailed description of the failure of signal/spectrum analyzer and put it into the package along with it.
- 2) Pack the signal/spectrum analyzer with the original packing materials, so as to minimize possible damage.
- 3) Place cushions at the four corners of the outer packing carton, and place the instrument in the outer packing carton.
- 4) Seal the opening of the packing carton with adhesive tape and reinforce the packing carton with nylon tape.
- 5) Specify text like "Fragile" ! Do not touch! Handel with care!" and so on.
- 6) Please consign it as precision instruments.
- 7) Keep a copy of all shipping documents.

## NOTICE

### Precautions when packing the signal/spectrum analyzer

Using other materials for packing the signal/spectrum analyzer may damage the instrument. Never use polystyrene beads as packing materials because on the one hand, they cannot provide sufficient protection on the instrument, and on the other hand, they can be sucked in to the instrument fan by the static electricity generated, resulting in instrument damage.

## TIPS

### Instrument package and transportation

Please follow carefully the precautions described in "2.1.1 Unpacking" in this manual when transporting or handling the instrument.

## 7 Technical indicators and testing methods

The section introduces the technical indicators and testing methods of the S4052 series signal/ spectrum analyzer.

Statement	1 2 1
Product Features	1 2 2
Technical Indicators	1 2 3
Additional Information	1 2 7
Performance Characteristic Test	1 2 7

### 7.1 Statement

The test conditions for all specifications are under the temperature of  $23^{\circ}\text{C}\pm 5^{\circ}\text{C}$  (half an hour after startup), unless otherwise specified. The additional instrument information is to facilitate users to understand more clearly the instrument performance that is not contained in the range of technical specifications. Key word descriptions are shown below:

**Technical specification (spec):** Place the calibrated instrument in the working environment of  $0^{\circ}\text{C} - 40^{\circ}\text{C}$  for at least 2h, and then warm it up for 30 min., so as to ensure its performance (including the measurement error), unless otherwise specified. All data in the document are technical specifications, unless otherwise specified.

**Typical value (Typ):** It indicates 80% of the instruments can reach typical performance, which is not a guarantee, and excludes uncertainty factors during the measurement. It is valid only at the room temperature (about  $25^{\circ}\text{C}$ ).

**Nominal value (nom):** It indicates such performances as the expected average performance or designed performance features, for

7.2 Product features

example, the 50 Ω connector. The measured values are not guaranteed data and are measured at room temperature (approximately 25 °C).

Measured value (meas): It indicates the performance feature measured during the design phase for comparing with the expected performance, for example, amplitude drifting change with time. Such data is not a guarantee, which is also taken at the room temperature (about 25°C).

7.2 Product features

Table 7.1 Product features

General Technical Indicators	
<b>Temperature range</b>	When working: 0 to +50°C When storing: -40 to +70°C
<b>Elevation</b>	4,600 m
<b>Electromagnetic compatibility</b>	Complies with the following provisions in 3.9.1 of GJB 3947A-2009: a) Power terminal disturbance: According to the provisions of GB4824-2004, the frequency is 150kHz - 30MHz, meeting the voltage limit requirements of Class B equipment in Group 1; b) Immunity to conducted disturbances induced by radio frequency fields: According to the provisions of GB/T 17626.6--1998, the test level is level 2, with an effective value of 3V, a frequency of 150kHz - 80MHz, and an amplitude modulation of 80% for a sinusoidal wave of 1kHz; c) Electrical fast transient pulse group immunity: According to the provisions of GB/T 17626.4--1998, the test level is level 3, with a peak value of 2kV for AC lines, 1kV for signal, control, and DC lines, a rise time Tr=5ns, a hold time Th=50ns, and a repetition frequency of (5-100) kHz; d) Electromagnetic radiation disturbance: According to the provisions of GB/T 4824--2004, the frequency is between 30MHz and 1000MHz, meeting the electromagnetic radiation disturbance limit requirements for Class B equipment in Group 1; e) Electromagnetic radiation immunity: According to the provisions of GB/T 17626.3--2006, the test level is level 2, with a field strength of 3V/m, a frequency range of 80MHz - 1000MHz, and an amplitude modulation of 80% for a sinusoidal wave of 1kHz; f) Electrostatic discharge immunity: According to the provisions of GB/T 17626.2--2006, the test level is level 3, with 6kV contact discharge and 8kV air discharge.
<b>Safety</b>	Complies with the security authentication requirements of 3.10 in GJB 3947A-2009. (a) When the power switch is on, the insulation resistance between the power input end of the equipment and the casing should not be less than 100 MΩ under standard atmospheric conditions for testing, and that should not be less than 2 MΩ in humid environment. (b) When a 1500 V AC voltage is applied between the power input end of the equipment and the casing, there should be no breakdown, flashover or flicker. (c) During the operation of the equipment, the current leaked between the instrument casing and the ground shall be no more than 3.5 mA.

## 7.3 Technical Specifications

<b>Power supply requirement</b>	<b>Voltage and frequency (rated value)</b>	110 ~ 240 V, 50 ~ 60 Hz The allowable range of the stability voltage is $\pm 10\%$ of the rated value, and that of the stability frequency is $\pm 5\%$ of the rated value.
	<b>Power consumption</b>	Maximum power consumption: 400 W Maximum standby power consumption: 20 W
<b>Display screen</b>		1920x1080, XGA 11,6"
<b>Data/Memory</b>		256G SSD Support storage devices compliant with USB 2.0/3.0 standards.
<b>Weight</b>		Net weight: less than 25 kg Packing and shipping weight: 34 kg (rated value)
<b>Size</b>		Width (mm) × Height (mm) × Depth (mm): (426 ± 4) mm × (177 ± 4) mm × (450 ± 4) mm (excluding handle, leg, padding block and side strap). Width (mm) × Height (mm) × Depth (mm): (475 ± 4) mm × (193 ± 4) mm × (560 ± 4) mm (including handle, leg, padding block and side strap).
<b>Quality Assurance</b>		S4052 signal/spectrum analyzer enjoys a standard warranty period of 18 months
<b>Reliability</b>		MTBF ( $\theta_0$ ) $\geq 5000$ h
<b>Calibration cycle</b>		The recommended calibration cycle is one year and the calibration service is provided by a professional calibration institution.

## 7.3 Technical Specifications

## 7.3.1 Frequency Range

Model	Frequency Range (DC Coupling)	Frequency Range (AC Coupling)
Type A	2Hz - 4GHz	10MHz - 4GHz
Type B	2Hz - 8GHz	10MHz - 8GHz
Type C	2Hz - 13.6GHz	10MHz - 13.6GHz
Type D	2Hz - 18GHz	10MHz - 18GHz
Type E	2Hz - 26.5GHz	10MHz - 26.5GHz
Type F	2Hz - 40GHz	10MHz - 40GHz
Type G	2Hz - 45GHz	10MHz - 45GHz
Type H	2Hz - 50GHz	10MHz - 50GHz

## 7.3.2 Frequency reference (10MHz)

Frequency accuracy:  $\pm$ (to last calibration date  $\times$  aging rate + temperature stability + calibration accuracy);

Aging rate:  $\pm 5 \times 10^{-10}$ /day

Temperature stability:  $\pm 5 \times 10^{-8}$ ;

Available initial calibration accuracy:  $\pm 4 \times 10^{-8}$ .

Note: By default, the time until the last calibration is 1 year.

## 7.3.3 Residual Frequency Modulation

$\leq 0.25$  Hz  $\times$  N (10 Hz resolution bandwidth, 10 Hz video bandwidth, and rated value within 20 ms; for the specific value of N, refer to the number of harmonics in section "Band Division.")

Note: N value (Number of LO harmonics)	Band Number	Frequency Range
1 Band 0	2Hz ~ 4.1GHz	
1 Band 1	2Hz ~ 4.1GHz	

## 7 Technical indicators and testing methods

### 7.3 Technical Specifications

2 Band 2	2Hz ~ 4.1GHz
4 Band 3	2Hz ~ 4.1GHz
4 Band 4	2Hz ~ 4.1GHz
8 Band 5	2Hz ~ 4.1GHz

#### 7.3.4 Frequency Readout Accuracy

$\pm(\text{Frequency reading} \times \text{Frequency reference accuracy} + 0.10\% \times \text{span} + 5\% \times \text{Resolution bandwidth} + 2 \text{ Hz} + 0.5 \times \text{Horizontal resolution}^*)$

\* Horizontal resolution = span / (Number of sweep points - 1). The default number of sweep points of series is 1001.

#### 7.3.5 Markers Counting

Accuracy:  $\pm(\text{Marker frequency} \times \text{Frequency reference accuracy} + 0.100 \text{ Hz})$

Counter resolution: 0.001Hz.

#### 7.3.6 Span Accuracy

Range: 0Hz (zero span), 10Hz~ the highest frequency range of this model

Resolution: 0.1Hz

Accuracy:  $\pm(0.1\% \times \text{span} + \text{Horizontal resolution})$

#### 7.3.7 Sweep Time and Trigger

Swp time range: 1  $\mu\text{s}$  ~ 16000s, span= 0 Hz

1 ms ~ 16000s, span $\geq$ 10 Hz

Sweep time accuracy (span=0Hz):  $\pm 0.01\%$

Trigger mode: Free, Video, Power Supply, External Trigger 1, External Trigger 2, Timer

Trigger delay: 0 ~ +500 ms

Trigger delay resolution: 0.1 $\mu\text{s}$

#### 7.3.8 Sweep Points Range

101 - 120001

#### 7.3.9 Resolution Bandwidth

Bandwidth range: 0.1Hz ~ 20MHz (1, 2, 3, 5 steps)

Bandwidth accuracy (3.01 dB):  $\pm 3\%$  1 Hz ~ 3MHz (1, 2, 3, 5 steps)

$\pm 15\%$  5MHz to 20MHz (in steps of 1, 2, 3, and 5)

Selectivity (-60 dB/-3 dB): 5.0:1

#### 7.3.10 Maximum Analysis Bandwidth

10 MHz Standard accessories

40MHz Options S4052-H38-40

200MHz Options S4052-H38-200

400MHz Options S4052-H38-400

600MHz Options S4052-H38-600

1200MHzOptions S4052-H38-

1200

#### 7.3.11 Video Bandwidth

Range: 1Hz ~ 20MHz (1, 2, 3, 5 steps)

#### 7.3.12 Input Attenuator Range

Input attenuator range : 0dB-70dB, 2dB step

Input electronic attenuator: 0dB - 30dB, 1dB step (option)

#### 7.3.13 Maximum Safe Input Level (Attenuation of 10dB and above)

Average total power: +30dBm(1W)

#### 7.3.14 Frequency Response (-10dBm Input Signal Level)

1) Mechanical attenuator 10dB, 20 °C - 30 °C, relative to 500MHz calibration frequency point, without preamplifier or electronic attenuator options; Or there may be a preamplifier and the amplifier is off; There may be an electronic attenuator option and the electronic attenuator is off.

$\pm 0.40$	10MHz $\leq$ f <4GHz
$\pm 0.70$	4GHz $\leq$ f <8GHz
$\pm 2.00$	8GHz $\leq$ f <18GHz
$\pm 2.50$	18GHz $\leq$ f <26.5GHz

## 7 Technical indicators and testing methods

---

### 7.3 Technical Specifications

$\pm 2.80$        $26.5\text{GHz} \leq f < 40\text{GHz}$

±3.00 40GHz≤f ≤50GHz

2) Mechanical attenuator 40dB, 20 °C - 30 °C, relative to 500MHz calibration frequency point, preamplifier on;

Mechanical attenuator 10dB, 20 °C - 30 °C, relative to 500MHz calibration frequency point, electronic attenuator on, electronic attenuator 0dB.

±1.00 10MHz≤f <4GHz

±1.50 4GHz≤f <8GHz

±2.50 8GHz≤f <18GHz

±3.00 18GHz≤f <40GHz

±3.50 40GHz≤f ≤50GHz

Note: The maximum frequency range of the electronic attenuator is 8GHz.

### 7.3.15 Display Range

Scale type: Logarithmic and linear

Logarithm scale: 0.1 ~ 20 dB/grid, resolution: 0.01 dB

Scale unit: dBm, dBmV, dBμV, dBmA, dBμA, V, W, or A

**7.3.16 Overall absolute amplitude accuracy** (10 dB input attenuation, 20°C ~ 30°C, 1 Hz ≤ RBW ≤ 1 MHz, input signal -10 ~ -50 dBm, automatic coupling of all settings, any reference level, and any scale)

Technical Indicators Frequency Range

±0.24 dB 500 MHz calibration frequency

±(0.24 dB + Frequency response) All frequencies (except 500 MHz calibration frequency)

### 7.3.17 Input Voltage Standing Wave Ratio (Mechanical Attenuator 10dB, DC Coupling)

< 1.40 50MHz≤f <4GHz

< 1.50 4GHz≤f <8GHz

< 1.80 8GHz≤f <18GHz

< 1.70 18GHz≤f <45GHz

< 2.00 45GHz≤f ≤50GHz

### 7.3.18 Conversion error of resolution bandwidth

Technical Indicators RBW Range

±0.10dB 1Hz -1MHz (in steps of 1, 2, 3, and 5)

±0.30dB 2MHz - 10MHz (in steps of 1, 2, 3, and 5)

±1.00dB 20MHz

Note: RBW=300kHz is used as a reference.

### 7.3.19 Reference Level (sensitivity-preferred RF gain coupling)

Range: Logarithmic scale: -170 dBm~ +30 dBm, with a 0.01 dB step.

Linear scale: 707 pV ~ 7.07 V, 0.11% (0.01 dB) resolution

Conversion error: ±0.20dB

### 7.3.20 Display Scale Fidelity

±0.20 dB Input the frequency mixer level ranging from -10 dBm to -80 dBm

### 7.3.21 Trace Detection Mode

Normal, positive peak, negative peak, sampling, video averaging, power averaging, and voltage averaging

### 7.3.22 1dB Gain Compression (dual tone testing, mixer level)

Input Mixer Level	Frequency Range
≥+0dBm	10MHz≤f <100MHz
≥+0dBm	100MHz≤f ≤1GHz
≥+5dBm	1GHz<f ≤8GHz
≥+5dBm	8GHz<f ≤50GHz

**7.3.23 Display Average Noise Level** (input port connected to 50 Ω load, 0dB input attenuation, reference level ≤ -30dBm, normalized to 1Hz)

a) S4052A/B model:

1) No preamplifier/preamplifier off, temperature range 20 °C -30 °C.

≤-151 dBm 10MHz ~ 1GHz

≤-149 dBm 1GHz ~ 2GHz

## 7 Technical indicators and testing methods

### 7.3 Technical Specifications

≤-147dBm	2GHz ~ 3GHz
≤-144dBm	3GHz ~ 4GHz
≤-147 dBm	4GHz ~ 6GHz
≤-145dBm	6GHz ~ 8GHz

2) Equipped with H34A/H34 preamplifier option, preamplifier on and temperature range 20 °C -30 °C.

≤-156dBm	10MHz ~ 50MHz
≤-161dBm	50MHz ~ 4GHz
≤-161dBm	4GHz ~ 6GHz
≤-157dBm	6GHz ~ 8GHz

b) S4052 C/D/E/F/G/H model:

1) No preamplifier/preamplifier off, temperature range 20 °C -30 °C.

≤-149dBm	10MHz ~ 1GHz
≤-147dBm	1GHz ~ 2GHz
≤-146dBm	2GHz ~ 3GHz
≤-141dBm	3GHz ~ 4GHz
≤-142dBm	4GHz ~ 6GHz
≤-139dBm	6GHz ~ 8GHz
≤-145dBm	8GHz ~ 18GHz
≤-141dBm	18GHz ~ 26.5GHz
≤-135dBm	26.5GHz ~ 40GHz
≤-134dBm	40GHz ~ 45GHz
≤-130dBm	45GHz ~ 50GHz

2) Equipped with H34-XX preamplifier option, preamplifier on and temperature range 20 °C -30 °C.

≤-156dBm	10MHz ~ 50MHz
≤-161dBm	50MHz ~ 4GHz
≤-161dBm	4GHz ~ 6GHz
≤-157dBm	6GHz ~ 8GHz
≤-157dBm	8GHz ~ 18GHz
≤-154dBm	18GHz ~ 26.5GHz
≤-151dBm	26.5GHz ~ 40GHz
≤-148dBm	40GHz ~ 50GHz

#### 7.3.24 Residual Response (input port connected to 50 Ω load, 0dB input attenuation, reference level < -30dBm)

Technical Indicators Frequency Range

≤-90dBm	200kHz ~ 8GHz
---------	---------------

#### 7.3.25 Second-harmonic intercept point (SHI)

SHI	Distortion Product	Mixer Level	Input Frequency Range
+45dBm	-60dBc	-15dBm	10MHz ~ 2GHz
+45dBm	-60dBc	-15dBm	2GHz ~ 4GHz
+55dBm	-70dBc	-15dBm	4GHz ~ 8GHz
+50dBm	-65dBc	-15dBm	8GHz ~ 25GHz

#### 7.3.26 Third Order Inter-modulation Distortion (TOI) (input two -10 dBm signals to mixer for test, frequency interval 50 kHz, 20°C ~ 30°C, rated value)

TOI	Frequency Range
≥+12dBm	10MHz ~ 200MHz
≥+17dBm	200MHz ~ 4GHz
≥+16dBm	4GHz ~ 8GHz
≥+18dBm	8GHz ~ 50GHz

#### 7.3.27 Phase Noise (carrier 1 GHz, 20°C ~ 30°C)

<-95dBc/Hz	100Hz
<-112dBc/Hz	1kHz
<-122dBc/Hz	10kHz
<-122dBc/Hz	100kHz

<-135dBc/Hz      1MHz

### 7.3.28 IQ Data

Maximum storage depth (IQ length):

Analysis bandwidth  $\leq$  40MHz: 500M IQ sampling points, IQ byte length: 32-bit I, 32-bit Q

Analysis bandwidth > 40MHz: 1000M IQ sampling points, IQ byte length: 16-bit I, 16-bit Q

### 7.3.29 Mirror Response (-10dBm mixer level)

Image response	Tuning frequency (f)	Stimulus frequency
$\leq -80$ dBc	10MHz~4.0GHz	f + -150 MHz
$\leq -80$ dBc	4GHz~8.0GHz	f + 150 MHz
$\leq -80$ dBc	8GHz~26.5GHz	f + -150 MHz
$\leq -80$ dBc	26.5GHz~40GHz	f + 150 MHz
$\leq -76$ dBc	40GHz~50GHz	f + -150 MHz
$\leq -80$ dBc	10MHz~4GHz	f + +850 MHz
$\leq -80$ dBc	4GHz~8GHz	f + -850 MHz
$\leq -80$ dBc	8GHz~18GHz	f + +850 MHz
$\leq -70$ dBc	18GHz~26.5GHz	f + +850 MHz
$\leq -70$ dBc	26.5GHz~40GHz	f + -850 MHz
$\leq -70$ dBc	40GHz~50GHz	f + +850 MHz
$\leq -80$ dBc	10MHz~4.0GHz	f + +10450 MHz
$\leq -80$ dBc	4.0GHz~8.0GHz	f + +3950 MHz

## 7.4 Additional information

None

## 7.5 Performance characteristics test

Recommended Test Method.....	1 2 7
Interface .....	1 5 8
Recommended Instrument for Performance Characteristics Test .....	1 9 8

### 7.5.1 Recommended testing method

#### 7.5.1.1 Frequency range

##### a) Description of the test items

The frequency span indicates the span between the maximum frequency signal and the minimum frequency signal that can be received by the signal/spectrum analyzer.

Use a signal generator of high-frequency stability to produce signals within the nominal upper and lower limits of the S4052 spectrum analyzer to check whether the frequency measurement capability of the S4052 spectrum analyzer is adequate.

##### B) Test equipment

Composite signal generator —— E8257D/1465L is recommended

Frequency standards

##### c) Test steps

- 1) According to Figure 1, connect the frequency standard output port to the 10 MHz input port of the signal generator to enable external frequency standards to provide reference frequencies for the composite signal generator; connect the

**7.5 Performance characteristics test**

low-frequency output port of the composite signal generator to the input port of S4052 (If no frequency standards are available, a signal generator or a frequency meter with a highly-stable frequency reference option can be used instead).

- 2) As shown in the solid line in Figure 1, connect the low-frequency output port of the composite signal generator to the radio frequency (RF) input port of S4052.
- 3) Set the composite signal generator as follows: Enable AM modulation; set AM Modulation Amplitude to 80%; set Modulation Rate to 2 Hz; set Low-frequency Output Amplitude to 100 mVp; enable low-frequency output.
- 4) Reset S4052 and set its mode to Spectrum Analysis; set I/O Coupling Mode to DC; set Center Frequency to the lower limit of nominal frequency 2 Hz; set span to 10 Hz. After a test is properly conducted, press the Peak key; the marker points to the maximum signal; the marker amplitude value has no obvious jitter; the signal can be clearly distinguished; record the center frequency at this time as the lower-limit measurement frequency; otherwise, record Fail to meet the requirements (If the signal peak value is displayed at zero frequency, zero-frequency automatic adjustment shall be performed).
- 5) As shown in the dotted line in Figure 1, change the test connection relationship by connecting the RF output port of the composite signal generator to the RF input port of S4052.
- 6) Set Output Frequency of the composite signal generator to the upper limit of nominal frequency for the S4052 to be tested; set Output Power to -10 dBm; set RF Output to ON; set Modulation Function to OFF.
- 7) Set S4052 Center Frequency to the upper limit of nominal frequency; set span to 20 kHz. Press the Peak Search key; the marker points to maximum signal response; the marker amplitude value has no obvious jitter; the signal can be clearly distinguished; record the center frequency at this time as the upper-limit measurement frequency; otherwise, record Fail to meet the requirements.

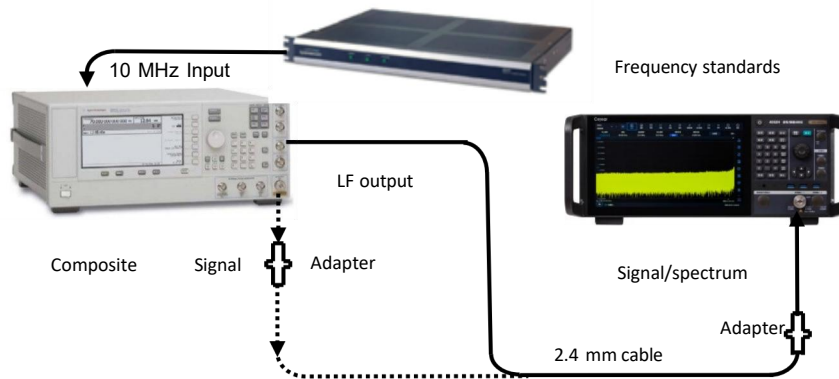

Figure 7.1 Diagram of the frequency range test

- 8) Record measurement results in corresponding test items in Signal/Spectrum Analyzer Test Records (hereinafter referred to as "S4052 Record Sheet") according to test instrument models and option features.
- 9) Set I/O coupling mode of S4052 to AC and repeat step 3) to step 8). The signals for testing the lower limit of frequency come from RF output of the signal generator.

d) Test record and data processing

Record measurement results in corresponding test items in **S4052 Records**.

**7.5.1.2 Frequency Reference**

a) Description of the test items:

Frequency reference is the basis for frequency measurement of the signal/spectrum analyzer. The frequency reference requires high frequency accuracy and stability. The equipment for testing the aging rate and temperature stability is complex; the test requires a long time. Field test is not applicable. In the process of acceptance, appraisal and production inspection of signal analysis equipment, the accuracy test on the reference frequency is the main inspection target. The available initial calibration accuracy is the component design rating. The aging rate and temperature stability are based on the factory test data of the crystal oscillator manufacturer. For details about the test method, see JJG 180--2002 Quartz Crystal Oscillators in Electronic Measuring Instruments or other equivalent test methods.

b) Testing equipment

Composite signal generator — E8257D/1465L is recommended

**7.5 Performance characteristics test**

Frequency standards

**7.5 Performance characteristics test**

c) Test steps

- 1) According to Figure 2, connect the frequency standard output port to the 10 MHz input port of the signal generator to enable external frequency standards to provide reference frequencies for the composite signal generator. Connect the RF output port of the composite signal generator to the input port of S4052 (If no frequency standards are available, a frequency meter with highly-stable frequency references can be used instead).
- 2) Preheat the S4052 to be tested, composite signal generator and frequency standards for a specified time;
- 3) Set the output frequency of the composite signal generator to the upper limit of maximum frequency for the S4052 model to be tested; set the output power to -10 dBm.
- 4) Reset S4052; set span to 100 kHz; press Peak Search; enable marker counting.
- 5) In B1 of the *Auxiliary Table for Performance Test on the S4052 Signal/Spectrum Analyzer (hereinafter referred to as "S4052 Auxiliary Table")*, record the measurement results of S4052 marker counting f.

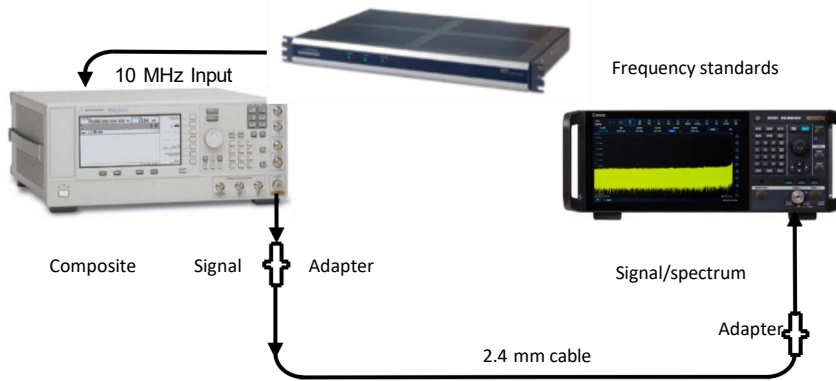

Figure 7.2 Diagram of the frequency reference test

d) Test record and data processing

- 1) According to formula (1), calculate the frequency reference and frequency accuracy; record them in the S4052 Record Sheet.

$$S = \frac{f - f_0}{f_0} \dots\dots\dots (1.)$$

Where:

f- S4052 Marker Counter Measurement value, in Hz;

f<sub>0</sub> indicates the output nominal frequency of the composite signal generator (unit: Hz).

- 2) Record the calculation results of the frequency reference and frequency accuracy in corresponding test items in the S4052 Record Sheet. The aging rate, temperature stability and calibration accuracy are provided by the measurement certificates that are issued after batch sampling inspection.

**7.5.1.3 Residual Frequency Modulation**

a) Description of the test items:

Residual FM is the inherent short-term frequency instability of a local oscillator signal in the absence of any modulation input, and generally refers to the peak or peak-to-peak value of the frequency jitter over a specified time interval for a specified test bandwidth.

By inputting a stable sine wave signal into the analyzer and setting the analyzer's zero span, any instability of the analyzer's LO system is transmitted to the IF through the mixing process. Measure the amplitude deviation detected on the sideband with a 10Hz resolution bandwidth, multiply it by the slope of the 10Hz filter slope, and convert the amplitude deviation into frequency deviation, i.e. residual FM.

b) Testing equipment

Composite signal generator —— E8257D/1465L is recommended

7.5 Performance characteristics test

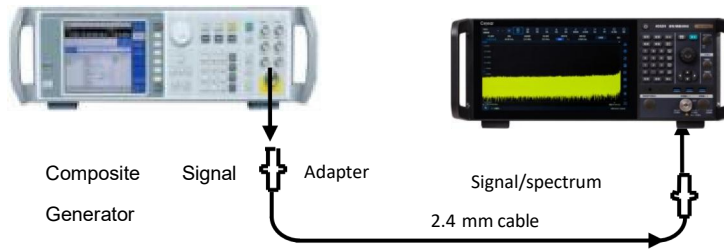

Figure 7.3 Schematic diagram of residual FM test

c) Test steps

- 1) Connect the test equipment as shown in Figure 3.
- 2) Set the frequency of the composite signal generator to 1 GHz; set the amplitude to 0 dBm.
- 3) Reset S4052 and make the following settings:  
 Center frequency..... 1 GHz  
 Span ..... 1 MHz
- 4) Gradually reduce the span of S4052 to 100Hz, and the Marker - Center operation makes the signal at the center frequency through peak search;
- 5) Set S4052 as the amplitude scale of 2dB/grid, adjust the output amplitude of the signal generator to make the signal peak at the reference level;
- 6) S4052 performs peak search, adjusts the peak to the center, and performs Delta Marker operations;
- 7) The signal/spectrum analyzer performs a Delta Marker operation by turning the knob counterclockwise on the S4052 until the Delta Marker amplitude reading is closest to -5 dB;
- 8) The signal/spectrum analyzer rotates the knob counterclockwise until the Delta Marker amplitude reading is closest to -10 dB;
- 9) Record the frequency difference  $\Delta f$  and amplitude difference  $\Delta L$  of the Delta Marker at this time, calculate the demodulation sensitivity S according to Equation (2), and record it in the S4052 Auxiliary Table;

$$S = \frac{\Delta f}{\Delta L} \dots\dots\dots (2.)$$

- 10) S4052 performs peak marker operation and Delta Marker operation. Rotate the knob counterclockwise until the Delta Marker amplitude reading is closest to -10dB. At this point, the marker point is in 1Hz steps. Select the marker point closest to -10dB, perform the marker to center operation, and set the span to zero;
- 11) Set the sweep time of the signal/spectrum analyzer to 1s, perform the single measurement operation, the peak search and the delta marker operation, and rotate the knob to move the marker to the lowest point. Record the absolute value of the delta marker amplitude (amplitude deviation)  $\Delta A$  in the S4052 Auxiliary Table B2;
- 12) Change the output frequency of the signal generator and the center frequency of S4052, repeat steps 2) to 11).

d) Test record and data processing

- 1) Calculate the residual frequency modulation  $R_{FM}$  according to Equation (3) and record it in the S4052 Auxiliary Table B.2;

$$R_{FM} = \Delta A \times S \dots\dots\dots (3.)$$

- 2) Perform error judgment on the calculation results of all test items in the S4052 Auxiliary Table B.2. If all test data are within the error range, record the calculation results in the corresponding positions in the S4052 Record Sheet. Otherwise, it is judged as non-compliant.

7.5.1.4 Frequency readout accuracy

1) Description of the test items

The frequency reading accuracy indicates the proximity between the indicated value of frequency measurement on the signal/spectrum analyzer and the corresponding true value. During frequency scanning of the signal/spectrum analyzer, the indicated value of frequency measurement is affected by factors such as reference frequency, scan width, resolution bandwidth and local-oscillator residual frequency modulation. Use an input signal of a known frequency to test the marker reading accuracy of the signal/spectrum analyzer.

2) Test equipment

Composite signal generator —— E8257D/1465L is recommended

3) Test steps

**7.5 Performance characteristics test**

- 1) According to Figure 2, connect the signal output port of the signal generator to the signal input port of the signal

## 7.5 Performance characteristics test

- generator.
- 2) Reset the signal generator; set Output Frequency to 1.5 GHz; set Power Level to -10 dBm; set RF Output to ON.
  - 3) Reset S4052; set Center Frequency to 1.5 GHz; set span to the corresponding value in the S4052 Record Sheet.
  - 4) Perform the marker operation on S4052; the corresponding marker value at this time is the set value for Center Frequency; then perform the delta marker operation.
  - 5) Perform peak search on S4052; record the frequency difference marked by the obtained peak value in the corresponding test item of the S4052 Record Sheet as test results.
  - 6) Set S4052 span according to the span value in the corresponding test item of the S4052 Record Sheet. Repeat step 5.
  - 7) Disable all markers. Repeat step 2 to step 6 for all groups of frequencies and spans that are listed in the corresponding test item of the S4052 Record Sheet.

## 7.5.1.5 Marker Counter

## a) Description of the test items

The output of a signal generator with a known frequency is used as the standard, and the error between the signal/spectrum analyzer Marker Counter value and the output of the signal generator is used as the Marker Counter accuracy.

## B) Test equipment

Composite signal generator —— E8257D/1465L is recommended

## c) Test steps

- 1) Connect the test equipment according to Figure 4, connect the 10MHz output terminal of S4052 to the 10MHz Input port of the composite signal generator, and connect the RF output terminal of the composite signal generator to the signal input terminal of S4052;
- 2) Reset S4052 and set the span to 1MHz. Turn on the Marker Counter Function of the marker and set the gating time to 5s;
- 3) Check the resolution of S4052 Marker Counter. If the test value shows that it meets the requirement of 0.001Hz, record it as 0.001Hz; otherwise it is judged as non-compliant;
- 4) Set the output frequency of the composite signal generator and the center frequency of S4052 to  $f_0$  according to the corresponding test item in the S4052 Auxiliary Table B.3;
- 5) S4052 performs peak search and records the frequency value  $f_s$  of the Marker Counter in the corresponding test item in the S4052 Auxiliary Table B.3;
- 6) Repeat steps 4) to 5) for all frequency points listed in the corresponding test items in the S4052 Auxiliary Table B.3 中对应测试项中的所有频率点重复步骤 4.

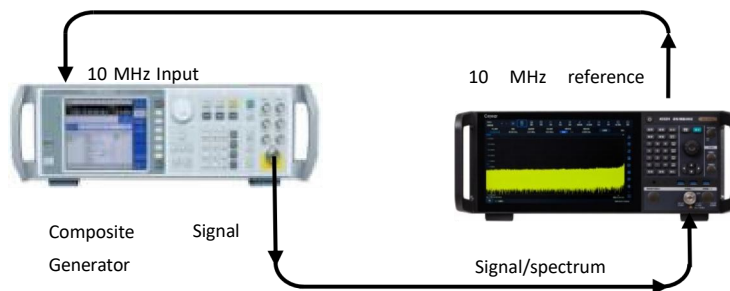

Figure 7.4 Schematic diagram of Marker Counter test

## d) Test record and data processing

- 1) Calculate the Marker Counter accuracy  $\Delta f$  according to Equation (4) and record it in the S4052 Auxiliary Table B3;

$$\Delta f = f_s - f_0 \dots\dots\dots (4.)$$

- 2) Record the calculation results of all test items in B3 of the S4052 Auxiliary Table in the corresponding table of the S4052 Record Sheet.

## 7.5.1.6 Span Accuracy

## a) Description of the test items

Use two composite signal generators to provide signals with the frequency difference of the signal/spectrum analyzer's  $0.8 * \text{SPAN}$ ; set Center Frequency of the signal/spectrum analyzer to the median of the output frequencies of the two signal generators. Use the

## 7.5 Performance characteristics test

flag function to measure the frequency difference between the two signals. Calculate and record the percentage of the error between the measured flag difference and the frequency bandwidth. Enable the two signal generators to share a reference frequency with the signal/spectrum analyzer.

It can also be tested with a signal generator. First, set Center Frequency and Span of the signal/spectrum analyzer; set signal generator to the frequency value of signal generator #1; set a delta marker on the signal/spectrum analyzer; then set the signal generator to the frequency value of signal generator #2; search the peak value; record the marker difference and frequency value at this time as measured values.

## B) Test equipment

Composite signal generator #1 — E8257D or 1465L is recommended

Composite signal generator #2 — E8257D or 1465L is recommended

Power splitter

## c) Test steps

- 1) Connect instruments according to Figure 5; reset S4052; set S4052 to provide frequency reference for two composite signal generators.

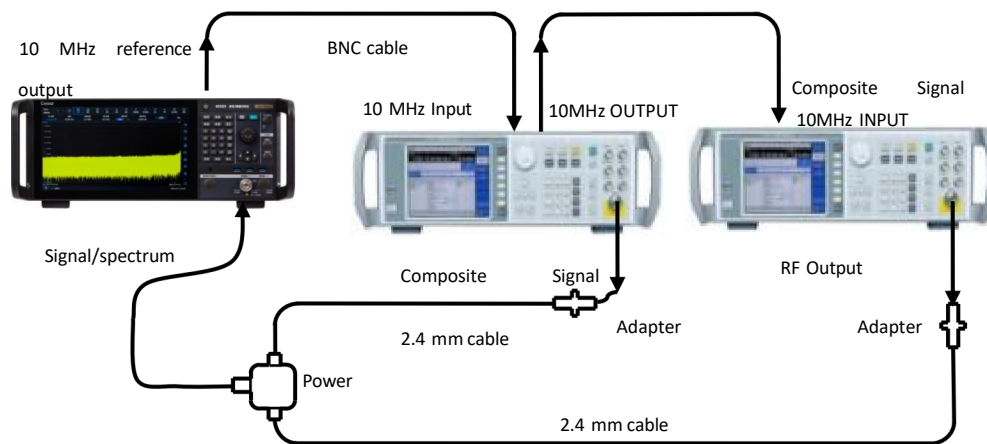

Figure 7.5 Diagram of the frequency-bandwidth accuracy test

- 2) Set composite signal generator #1 as follows: Set Output Power to 0 dBm; set RF Output to ON.
  - 3) Set composite signal generator #2 as follows: Set Power to -10 dBm; set RF Output to ON.
  - 4) Set S4052 according to the mapping between span and Center Frequency in B4 of the S4052 Auxiliary Table.
  - 5) Set composite signal generators according to frequency of composite signal generator #1 and composite signal generator #2 in B4 of the S4052 Auxiliary Table.
  - 6) S4052 performs single sweep and waits the completion of new sweep. Then, perform peak search and difference mark operations; finally, perform sub-peak search.
  - 7) Record the frequency value of the delta marker  $\Delta f$  displayed on S4052;
  - 8) Repeat step 5) to step 8) for all set values of spans and frequencies of signal generators that are listed in the corresponding test item in B.4 of the S4052 Auxiliary Table.
- d) Test record and data processing
- According to formula (5), calculate the span accuracy  $\delta_{SPAN}$  and record it in the S4052 Record Sheet.

$$\delta_{SPAN} = \left( \frac{\Delta f - 0.8 * SPAN}{0.8 * SPAN} \right) \dots\dots\dots (5.)$$

Where:

$\Delta f$  - the frequency value of the delta marker  $\Delta f$  displayed on S4052, in Hz;

$SPAN$  indicates the span set on S4052 (unit: Hz).

### 7.5.1.7 Sweep Time and Trigger

#### a) Description of the test items

The amplitude modulated signal is demodulated in the zero span state of the signal/spectrum analyzer to obtain the amplitude cycle signal. After the modulation rate of the modulated signal reasonably corresponds to the sweep time of the signal/spectrum analyzer, the demodulated signal interval is evenly distributed on the screen. The demodulated signal peak is counted to get the actual sweep time, and then compared with the specified time to get the sweep time accuracy. Sweep time accuracy is guaranteed by design, and a typical sweep time test is selected for verification in order to reduce test time.

The trigger function of the signal/spectrum analyzer is guaranteed by the design.

#### B) Test equipment

Composite signal generator —— E8257D is recommended

Function generator

Note: If the composite signal generator does not have the function of built-in amplitude modulation option, a function generator can also be used as an external modulation source.

#### c) Test steps

- 1) Connect the test equipment according to Figure 4, reset S4052, connect the signal generator output to the input of the S4052 under test, and connect the 10MHz output terminal of the S4052 to the 10MHz input port of the composite signal generator;
- 2) Set the output frequency of the signal generator to 1GHz, output amplitude to -5dBm, "Internal AM" modulation method, modulation depth of 80%, and set the modulation waveform to triangular wave output;
- 3) Set the center frequency of S4052 to 1GHz, with a span of 100MHz. The minimum sweep time can be set to 1ms, and the maximum sweep time can be set to 16000s. If the above settings meet the requirements of the S4052 Record Sheet, it is recorded as compliant; otherwise it is judged as non-compliant;
- 4) Set the span of S4052 to 0Hz and change the sweep time range. The minimum can be set to 1  $\mu$ s and the maximum can be set to 16000s.  
If the above settings meet the requirements of the S4052 Record Sheet, it is recorded as compliant; otherwise it is judged as non-compliant;
- 5) Set the linear scale of S4052, positive peak detection method, resolution bandwidth of 3MHz;
- 6) According to the corresponding test items listed in the S4052 Auxiliary Table B.5, set the sweep time of S4052 and the AM modulation frequency of the signal generator;
- 7) S4052 performs a single measurement operation and reads the time difference  $\Delta T$  between the 2nd peak and the 10th peak on the left using the delta marker and records it in the S4052 Auxiliary Table B.5;
- 8) According to the requirements in the S4052 Auxiliary Table B.5, set different sweep times and repeat steps 6) to 7);
- 9) There are 6 trigger methods for setting S4052, including Free, Video, Power, External Trigger 1, External Trigger 2, and Timer. If set to Free Trigger mode, the spectrum trace should be able to refresh normally;
- 10) Set the output frequency of the signal generator to 2GHz, output power to -20dBm, pulse modulation output, pulse width of 1ms, and pulse period of 2ms; Connect the RF output interface to the S4052 RF input interface; Set the frequency of S4052 to 2GHz, and the triggering method is video triggering; Reduce the triggering level. If the signal spectrum trace can be refreshed, the S4052 video triggering method meets the technical requirements. Otherwise, it is judged as non-compliant;
- 11) Set the output frequency of the signal generator to 2GHz, output power to -20dBm, pulse modulation output, pulse width to 0.1ms, pulse period to 0.2ms, and connect the RF output interface to the S4052 RF input interface; Set the low-frequency output of the signal generator, with an output frequency of 1kHz and an output voltage of 1V; Connect the low-frequency output interface to the S4052 trigger input interface; Set the frequency of S4052 to 2GHz, and the triggering method is external triggering; Reduce the triggering level. If the signal spectrum trace can be refreshed, the S4052 external triggering method meets the technical requirements. Otherwise, it is judged as non-compliant;

**7.5 Performance characteristics test**

- 12) Trigger delay 0 to +500ms and trigger delay resolution 0.1μs can be checked by parameter setting, which is guaranteed by design;
- 13) If steps 9) to 12) pass the test, the S4052 triggering method meets the technical requirements and is recorded in the corresponding item of the S4052 Record Sheet as compliant; otherwise it is judged as non-compliant;
- d) Test record and data processing
  - 1) Calculate the sweep time accuracy  $\delta$  according to Equation (6).

$$\delta = \left( \frac{\Delta T - 0.8 \times T}{0.8 \times T} \right) \times 100\% \dots\dots\dots (6)$$

Where:

$\Delta T$  - Time difference between the second peak and the 10th peak;  
 $T$  —sweep time set by S4052

- 2) Perform measurement judgment on all test items in B.5 of the S4052 Auxiliary Table. If all calculation results are within the error range, record the maximum deviation value in step 9 of the calculation results in the corresponding item of the S4052 Record Sheet; otherwise it is recorded as non-compliant.

**7.5.1.8 Sweep Points Range**

- a) Description of the test items

Swp Points refer to the number of trace data that the signal/spectrum analyzer needs to obtain for a measurement. If the number of sweep points is increased, the corresponding bandwidth of each trace data will be narrower, and the frequency reading accuracy will be higher.

The number of sweep points is guaranteed by the signal/spectrum analyzer manufacturer during design and manufacturing, and can be checked by setting sweep points.

- b) Test steps

- 1) Reset S4052, enter the sweep menu, set the sweep points, and the range of points that can be set at this time is from 101 to 100001;
- 2) Perform value judgment for requirements specified in 3.12.8. If all results are within the error limits range, fill in "Pass" in the S4052 Record Sheet; otherwise, fill in "Fail" therein.

**7.5.1.9 RBW**

- a) Description of the test items

The frequency resolution indicates the capability of the signal/spectrum analyzer to distinguish minimum constant-amplitude signals.

Signal generators produce standard sine waves. Change of signal generator's frequencies is equivalent to change of intermediate-frequency filter's frequencies. The test on the amplitude response of different frequency signals at a fixed frequency of the analyzer is equivalent to the test on the amplitude-frequency response of intermediate-frequency filter's each frequency; thus, the shape of the intermediate-frequency filter (including 3 dB bandwidth and rectangle coefficient) can be measured.

- B) Test equipment

Composite signal generator —— E8257D/1465L is recommended

- c) Test steps

- 1) Connect the instrument according to Figure 4. S4052 provides frequency reference for composite signal generators.
- 2) Set the composite signal generator as follows: Set Frequency to 500 MHz; set Power to -2 dBm; set Power Step to 1 dBm; Set RF Output to ON.
- 3) Reset S4052 and complete all calibration operations; enable NdB Bandwidth Measurement and change N to 3.01.
- 4) Set the center frequency of S4052 to 500MHz, span of 20MHz, amplitude scale of 1dB, resolution bandwidth of 20MHz, and VBW/RBW of 0.1; Set S4052 to Dynamic Range Priority for RF gain and 0dB for attenuator;
- 5) Adjust output amplitude of the composite signal generator so that the signal peak is 2 dB or 3 dB below the reference level.
- 6) S4052 performs continuous measurement, opens the marker, and sets the marker to 500MHz;
- 7) Perform single measurement and record the 3 dB bandwidth marker-difference reading  $\Delta f$  -3dB at this time in the 3 dB Bandwidth Measurement Value column in B6 of the S4052 Auxiliary Table.
- 8) Set S4052 according to the resolution bandwidth listed in B6 中所列的分辨率带宽设置 S4052 of the S4052 Auxiliary Table; set span

## 7.5 Performance characteristics test

- to approximately twice the resolution bandwidth. Repeat step 6 and step 7.
- 9) S4052 performs a reset operation, sets the S4052 to a center frequency of 500 MHz, a span of 100 MHz, a reference level of 0 dBm, an amplitude scale of 10 dB, a resolution bandwidth of 20 MHz, a VBW/RBW of 0.01, and sets the S4052 to an RF gain of Dynamic Range Priority, and an attenuator of 0 dB;
  - 10) Adjust output power of the composite signal generator until S4052 signal peak-amplitude reading is closest to 0 dBm. Enable NdB Bandwidth Measurement and change N to 60.
  - 11) S4052 performs continuous measurement, opens the marker, and sets the marker to 500MHz;
  - 12) Perform single measurement and record the 60 dB bandwidth marker-difference reading  $\Delta f_{-60dB}$  at this time in the 60 dB Bandwidth Measurement Value column in B.6 of the S4052 Auxiliary Table.
  - 13) Set S4052 according to the resolution bandwidth listed in B.6 中所列的分辨率带宽设置 S4052 of the S4052 Auxiliary Table; set span to approximately 5-10 times the resolution bandwidth. Repeat step 11) and step 12).
- d) Test record and data processing
- 1) According to formula (7), calculate the resolution bandwidth accuracy  $\delta$  and record it in the corresponding test item in the S4052 Record Sheet.

$$\delta = \left( \frac{\Delta f_{-3dB} - RBW}{RBW} \right) \times 100\% \dots\dots\dots (7.)$$

Where:

$\Delta f_{-3dB}$  indicates the measured 3 dB bandwidth value of S4052 (unit: Hz).

$RBW$  indicates the nominal value of resolution bandwidth for the tested S4052 (unit: Hz).

- 2) According to formula (8), calculate the resolution bandwidth selectivity  $S$  and record it in the corresponding test item in the S4052 Record Sheet.

$$S = \frac{\Delta f_{-60dB}}{\Delta f_{-3dB}} \dots\dots\dots (8.)$$

Where:

$\Delta f_{-60dB}$  indicates the measured 60 dB bandwidth value of S4052 (unit: Hz).

$\Delta f_{-3dB}$  indicates the measured 3 dB bandwidth value of S4052 (unit: Hz).

#### 7.5.1.10 Maximum Analysis Bandwidth

- a) Description of the test items

The standard maximum analysis bandwidth ( $BW_{max}$ ) of the S4052 is at 10MHz, with options H38-40 at 40MHz, H38-200 at 200MHz, H38-400 at 400MHz, H38-600 at 600MHz, and H38-1200 at 1200MHz. Set **S4052 Analysis Mode** to **IQ**; two composite signal generators with stable frequencies provide constant-amplitude signals for S4052 simultaneously. If frequencies of two signals are changed within the demodulation bandwidth and the amplitude difference between signals does not exceed 3 dB, the maximum analysis bandwidth is satisfied.

- b) Test diagram and test instruments and equipment

Composite signal generator #1 — E8257D/1465L is recommended

Composite signal generator #2 — E8257D/1465L is recommended

- c) Test steps

- 1) Connect test instruments and reset S4052 according to Figure 6.
- 2) Set S4052 as IQ analysis mode; set the frequency domain window as the current window. Set center frequency as 1 GHz; set analysis bandwidth as 10 MHz.
- 3) Set signal generator #1 as follows: Set Frequency to 1 GHz; set Amplitude to -10 dBm; perform the delta marker operation for S4052; disable Output of signal generator #1. Set signal generator #2 as follows: Set frequency to 1 GHz; set amplitude to -10 dBm; adjust its output amplitude so that the delta marker reading is closest to 0 dB.
- 4) Decrease the frequency of signal generator #2 in turn and perform peak search at the same time. If the marker amplitude reading is larger than  $\pm 3dB$ , record the output frequency of the signal generator at this time as the left limit value; otherwise, record the frequency value that is displayed in the left-most grid of the S4052 screen for the signal and record the result in the left limit value  $f_l$  column of the S4052 Auxiliary Table.
- 5) Disable output of signal generator #2 and enable output of signal generator #1.

7.5 Performance characteristics test

- 6) Increase the frequency of signal generator #1 in turn and perform peak search at the same time. If the marker amplitude reading is larger than ±3 dB, record the output frequency of the signal generator at this time as the right limit value; otherwise, record the frequency value that is displayed in the right-most grid of the S4052 screen for the signal and record the result in the right limit value  $f_R$  column in B.7 中对应右侧极限值  $f$  of the S4052 Auxiliary Table.

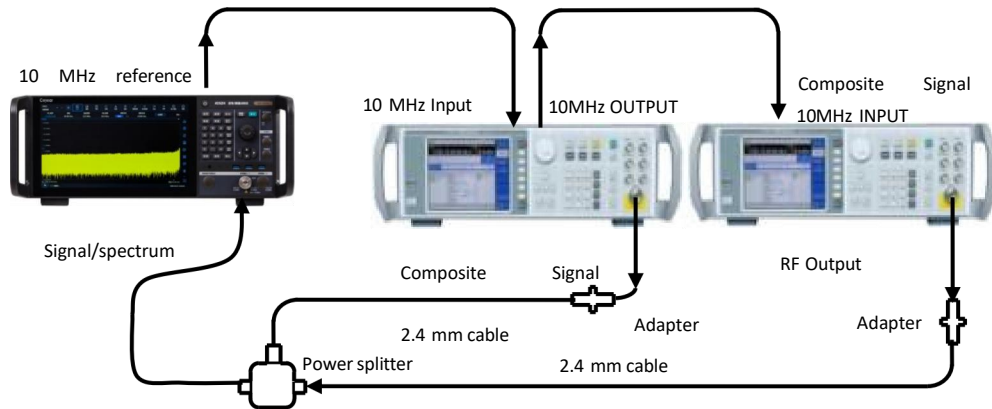

Figure 7.6 Diagram of the maximum analysis-bandwidth test

- 7) If broadband option H38 is provided, repeat step 2 to step 6 according to the set value for Analysis Bandwidth in B7 of the S4052 Auxiliary Table.
- d) Test record and data processing

According to formula (9), calculate the measured maximum analysis bandwidth  $BW$  and record  $BW_{MAX}$  in the corresponding item in the S4052 Record Sheet if  $BW \geq BW_{MAX}$ . Otherwise, record "Fail" therein.

$$BW = f_R - f_L \dots\dots\dots (9.)$$

Where:

- $f_R$  - right limit value, in MHz;
- $f_L$  indicates the left limit value (unit: MHz).

7.5.1.11 VBW

- a) Description of the test items

The video bandwidth indicates the bandwidth of the tunable low-pass filter in the video circuit behind the signal/spectrum analyzer detector. The video filter behind the detector is a low-pass filter determining the bandwidth of the video amplifier. With the noise smoothing function, it is used to average or smooth the trace; it can easily detect weak signals in noise. Change of the video bandwidth does not affect the frequency resolution of S4052. However, if the selected video bandwidth is too narrow, the scanning time would be increased. The video bandwidth is guaranteed by the signal/spectrum analyzer manufacturer during design and production. You can check it by video bandwidth settings.

- b) Testing steps

- 1) Reset S4052; enter the Bandwidth menu; the video bandwidth range at this time can be set to 1 Hz~3 MHz, 5 MHz, 10 MHz or 20MHz.
- 2) Perform value judgment for video bandwidth requirements specified in section 3.12.11. If all results meet the requirements, record "Pass" in the S4052 Record Sheet; otherwise, record "Fail" therein.

7.5.1.12 Input Attenuator Range

- a) Description of the test items

Used to investigate the setting range of S4052 mechanical attenuator and electronic attenuator (option)

- b) Testing steps

- 1) Reset S4052; set input port to internal 500 MHz. Set center frequency to 500 MHz; set span to 1 kHz; set resolution bandwidth to 100 Hz; set input attenuator to 0 dB; set reference level to -15 dBm.
- 2) Perform signal peak search and delta marker.
- 3) Set input mechanical attenuator to 2 dB, 4 dB, 6 dB, 8 dB, 10 dB, 20 dB, 30 dB, 40 dB, 50 dB, 60 dB and 70 dB respectively; the

**7.5 Performance characteristics test**

instrument can correctly display the amount of attenuation; record "Pass" in "Input Mechanical Attenuator Range" of the "S4052 Record Sheet". Otherwise, record "Fail" therein.

- 4) If an electronic attenuator is configured, proceed with this step; Reset S4052 and select the input port as internal 500MHz. Set center frequency to 500 MHz; set span to 1 kHz; set resolution bandwidth to 100 Hz; input the mechanical attenuator 0dB, the electronic attenuator 0 dB, and reference level -15 dBm.
- 5) Perform signal peak search and delta marker.
- 6) Set the input electronic attenuator value from 1dB to 30dB in steps of 1dB. If the instrument can correctly indicate the attenuation amount, it is recorded in the "Input Electronic Attenuator Range" in the S4052 Record Sheet as compliant; otherwise it is judged as non-compliant.

**7.5.1.13 Maximum safe input level**

## a) Description of the test items

The maximum safe input level refers to the maximum level allowed at the input end of the signal/spectrum analyzer without damaging the product, which is guaranteed by the component design.

The maximum safe input level is determined by generating a signal consistent with the maximum safe input level value into the signal/spectrum analyzer, and checking whether the signal/spectrum analyzer is damaged, to determine whether the maximum safe input level meets the requirement.

Due to the high risk of this experiment, when the ordering party has a clear demand, several frequency points can be selected for testing according to the following method.

## B) Test equipment

Composite signal generator —— E8257D/1465L is recommended

High Power Amplifier ..... Recommended 38701D/80244

Power meter host+high-power probe..... Recommended E9301B+N1914A

## c) Test steps

- 1) Set the signal output of the signal generator to OFF, set the frequency to 3GHz, the amplitude to -50dBm, and the power step to 0.1dB;
- 2) Reset S4052 and set the center frequency to 3GHz, span to 2MHz, and reference level to +30dBm;
- 3) Connect the test equipment as shown by the solid line in Figure 7, and connect the output cable of the high-power amplifier to the USB power meter sensor;
- 4) Turn on the RF output of the signal generator, set the amplitude key, use a knob to change the amplitude value, and gradually increase the signal power to make the test value of the power meter  $+30 \pm 0.1$ dBm. At this time, the port power of the output connection cable of the high-power amplifier is +30dBm;
- 5) Turn off the output of the signal generator, turn off the power supply of the high-power amplifier, change the test connection relationship according to the dotted line position shown in Figure 7, and connect the output cable of the power amplifier to the input of the signal/spectrum analyzer;
- 6) Turn on the RF output of the signal generator and the power switch of the high-power amplifier, and set the output power of the signal generator to - 65dBm after holding for 5 minutes;
- 7) Set signal/spectrum analyzer peak search and delta marker;
- 8) Change the attenuator attenuation of the signal/spectrum analyzer in steps of 2dB until all attenuation gears of the S4052 are set once, at which time the signal should have no significant jumps. Turn off the power supply of the high-power amplifier.

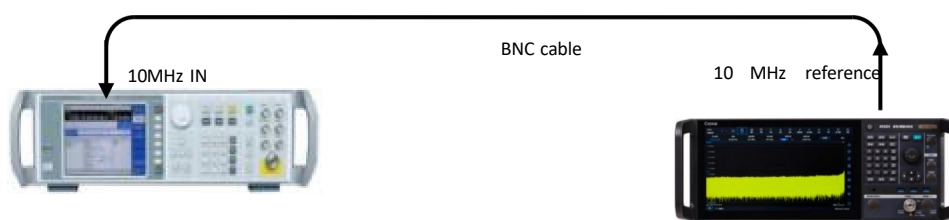

7.5 Performance characteristics test

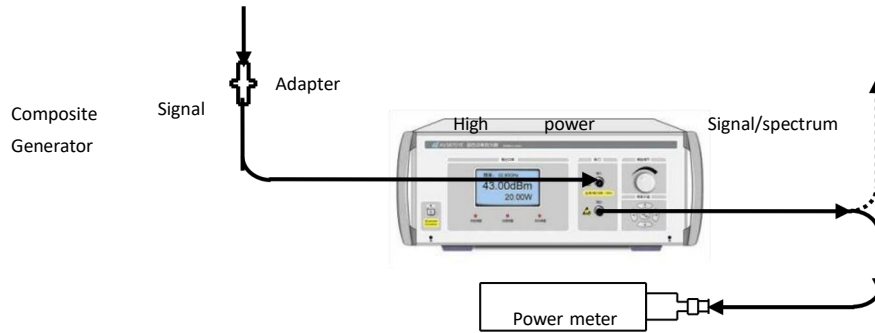

Figure 7.7 Maximum safe input level test

d) Record and data processing

If steps 1) to 8) can complete the test correctly, it means that the maximum safe input level of the S4052 signal is +30dBm, which complies with the requirements. +30dBm is recorded in the S4052 Record Sheet, otherwise, it is recorded as non-compliant.

7.5.1.14 Frequency Response

a) Description of the test items

The frequency response indicates the change of the amplitude with the frequency within the specified frequency span, that is, the dependency between the amplitude and the frequency.

Input the sine wave signal with Frequency Known and Power Known (power meter calibration) produced by the signal generator to the signal/spectrum analyzer; test the change of the amplitude with the frequency within the specified frequency span on the signal/spectrum analyzer.

b) Test diagram and test instruments and equipment

Composite signal generator — E8257D/1465L is recommended

Power meter: 2434/E4418B is recommended.

Power sensor: 71712A/N8487A is recommended.

Power splitter: 11667C is recommended.

c) Test steps

- 1) Connect test instruments according to Figure 8.
- 2) Set output frequency of the composite signal generator to 50MHz; set its amplitude to -4 dBm.
- 3) Reset S4052 and set it as follows:
 

Center frequency.....	50 MHz
Span .....	1 MHz
Resolution bandwidth.....	300 kHz
Video bandwidth .....	30kHz

If the Pre-amplifier option is provided, set it to OFF.
- 4) Set power meter frequency to 10MHz.
- 5) Record the S4052 marker reading  $L_2$  and power meter reading  $L_1$  in B.8 of the S4052 Auxiliary Table.
- 6) According to the next frequency value to be tested in the auxiliary table, set the output frequency of the composite signal generator, center frequency of S4052, and power meter frequency;
- 7) Record the S4052 marker reading  $L_2$  and power meter reading  $L_1$  in the S4052 Auxiliary Table; repeat steps 5) ~ 6).

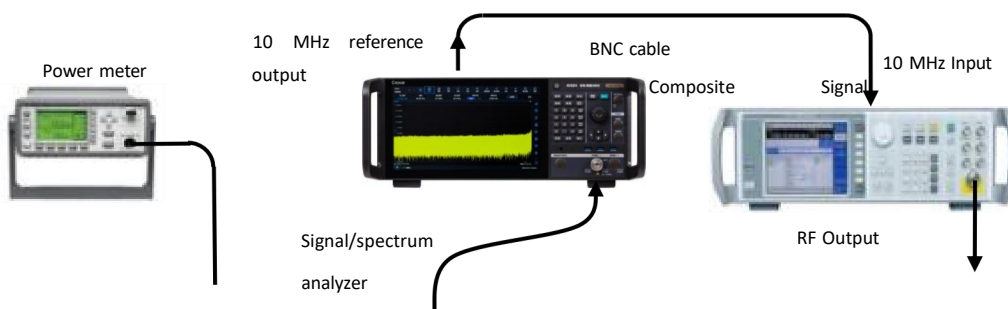

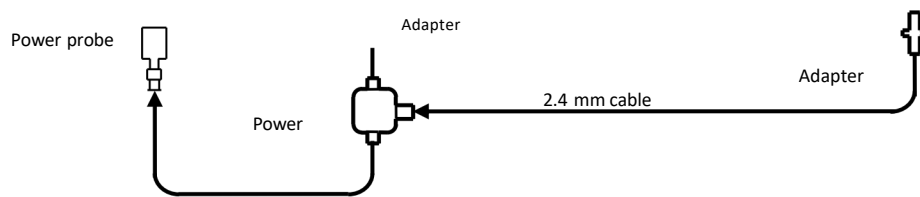

Figure 7.8 Diagram of the frequency response test (50 MHz to 50 GHz)

**Frequency response (8 GHz to 18 GHz)**

- 8) Set output frequency of the composite signal generator to 8.05 GHz. Set S4052 center frequency to 8.05 GHz; set frequency step to 500 MHz;
- 9) Set power meter frequency to 10MHz.
- 10) Record the S4052 marker reading  $L_2$  and power meter reading  $L_1$  in the S4052 Auxiliary Table.
- 11) According to the frequency points specified in the auxiliary table, set the output frequency of the composite signal generator and the center frequency of S4052;
- 12) Set power meter frequency to the next frequency value to be tested in B.8 of the S4052 Auxiliary Table. Repeat steps 8) ~ 11) for each frequency point in the table.

**Frequency response (8 GHz to 18 GHz)**

- 13) Set output frequency of the composite signal generator to 18.05 GHz; set S4052 center frequency to 18.05 GHz.
- 14) Set power meter frequency to 10MHz.
- 15) Record the S4052 marker reading  $L_2$  and power meter reading  $L_1$  in the S4052 Auxiliary Table.
- 16) Perform the frequency step up operation on the composite signal generator and S4052 simultaneously.
- 17) Set power meter frequency to the next frequency value to be tested in B.8 of the S4052 Auxiliary Table. Repeat steps 13) ~ 16) for each frequency point in the table.

**Frequency response (8 GHz to 18 GHz)**

- 18) Set output frequency of the composite signal generator to 18.05 GHz; set S4052 center frequency to 18.05 GHz.
- 19) Set power meter frequency to 10MHz.
- 20) Record the S4052 marker reading  $L_2$  and power meter reading  $L_1$  in the S4052 Auxiliary Table.
- 21) Perform the frequency step up operation on the composite signal generator and S4052 simultaneously.
- 22) Set power meter frequency to the next frequency value to be tested in B.8 of the S4052 Auxiliary Table. Repeat steps 18) ~ 21) for each frequency point in the table.

**Frequency response (8 GHz to 18 GHz)**

- 23) Set output frequency of the composite signal generator to 18.05 GHz; set S4052 center frequency to 18.05 GHz.
- 24) Set power meter frequency to 10MHz.
- 25) Record the S4052 marker reading  $L_2$  and power meter reading  $L_1$  in the S4052 Auxiliary Table.
- 26) Perform the frequency step up operation on the composite signal generator and S4052 simultaneously.
- 27) Set power meter frequency to the next frequency value to be tested in B.8 of the S4052 Auxiliary Table. Repeat steps 23) ~ 26) for each frequency point in the table.

**Frequency response (pre-amplifier enabled)**

- 28) If the pre-amplifier option is provided, perform operations by referring to step 1 to step 28; in step 3, enable the amplifier.
- d) Test record and data processing
- 1) Use Amplitude Error Compared with 50 MHz to minus 50 MHz Amplitude Error for each frequency point listed in Amplitude Error (0 Band, 2 Hz to 50 MHz) in B.8 of the S4052 Auxiliary Table; record the result in the table as the amplitude error of the current frequency point.
  - 2) According to formula (10), calculate and record the amplitude error  $\Delta A$  of the corresponding frequency point.

$$\Delta A = L_2 - L_1 \dots \dots \dots (10)$$

Wherein,  $L_1$  indicates the power meter reading (unit: dBm);

$L_2$  indicates the S4052 marker reading (unit: dBm).

- 3) In the corresponding frequency band of the technical specifications, find the positive maximum amplitude error  $\Delta A_{max}$  and

**7.5 Performance characteristics test**

the negative minimum amplitude error  $\Delta A_{min}$ ; record them in Frequency Response Statistics. Absolute values of and are required to be within the frequency response range of S4052. Otherwise, record "Fail" therein.

- 4) According to formula (11), calculate the frequency response  $\Delta A_p$  of each band; record the result in the corresponding band in the S4052 Record Sheet.

$$\Delta A_p = \pm \frac{\Delta A_{max} - \Delta A_{min}}{2} \dots\dots\dots (11.)$$

**7.5.1.15 Display Range**

- a) Description of the test items

The display range is a specification for the S4052 display scale type, logarithmic scale, and scale unit, which is guaranteed by the design.

- b) Testing steps

- 1) After the S4052 is powered on and starts up properly, perform a factory reset operation;
- 2) S4052 provides logarithmic and linear scale types under the amplitude menu;
- 3) Under logarithmic scale, manually set S4052 to meet the requirements of "0.1 - 20dB/grid, resolution of 0.01dB";
- 4) S4052 provides eight scale units: dBm, dBmV, dBμV, dBmA, dBμA, V, W, and A.

- c) Test record and data processing

If steps 1) to 4) can complete the test correctly, it means that the display range complies with the technical requirements. It is recorded as compliant in the S4052 Record Sheet; otherwise recorded as non-compliant.

**7.5.1.16 Overall Absolute Amplitude Precision**

- 1) Description of the test items

Set **S4052 Calibration Signal Frequency** to **500 MHz**; set **Amplitude** to **-20 dBm**. Internal amplitude calibration of S4052 is based on the preceding parameters. Change of the calibration signal amplitude may cause accuracy error of S4052 absolute amplitude measurement.

Use the signal generator to produce a signal with the same frequency and amplitude as those of the calibration signal; use the signal/spectrum analyzer and power meter to test the calibration signal and the produced signal respectively; the reading error for the two signals is regarded as the absolute amplitude precision of the calibration signal.

The absolute amplitude error of the instrument can be obtained by adding the absolute amplitude precision of the 500 MHz calibration signal to the frequency response of any frequency point.

- 2) Test diagram and test instruments and equipment

Composite signal generator —— E8257D/1465L is recommended

Power meter: 2434/N1914A is recommended.

Power sensor: N8488A, R&SZ61 and 71712 are recommended.

- 3) Test steps

- 1) Perform zeroing and calibration for the power meter. Reset S4052; complete all calibration operations; No error occurs. As shown in the solid line of Figure 9, connect test instruments; connect the output port of the signal generator to the power meter.
- 2) Set output frequency of the composite signal generator to 50MHz; set it amplitude to -4 dBm.
- 3) Set the power meter frequency to 500MHz and record the power meter reading L1 in the S4052 Auxiliary Table B.10 中记录功率计读数 L;
- 4) As shown in the dotted line in Figure 9, change the test connection relationship by connecting the cable to the S4052 through the adapter;
- 5) Set S4052 as follows:

Center frequency..... 500 MHz  
 Span ..... 1 MHz  
 Resolution bandwidth ..... 300kHz

**7.5 Performance characteristics test**

Video bandwidth ..... 30kHz

6) S4052 performs peak search and records the S4052 marker reading  $L_2$  in B.10 S4052 L of the S4052 Auxiliary Table.

4) Test record and data processing

1) According to formula (12), calculate the absolute amplitude accuracy  $\Delta A_{500}$  of the frequency point 500 MHz and record the result in the S4052 Record Sheet.

$$\Delta A_{500} = L_2 - L_1 \dots\dots\dots (12.)$$

Wherein,  $L_1$  indicates the power meter reading (unit: dBm);

$L_2$  indicates the S4052 marker reading (unit: dBm).

2) According to formula (13), perform calculation for each band of S4052 based on the test results of section 4.6.12.2.3 "xxx;" record the result as the overall absolute amplitude precision.

$$\Delta A_{ALL} = \pm (\Delta A_{500} + |\Delta A_P|) \dots\dots\dots (13.)$$

Where:

$\Delta A_{500}$  - 500MHz absolute amplitude accuracy, in dB;

$\Delta A_P$  - the frequency response data (in dB) obtained in section 4.6.15.14

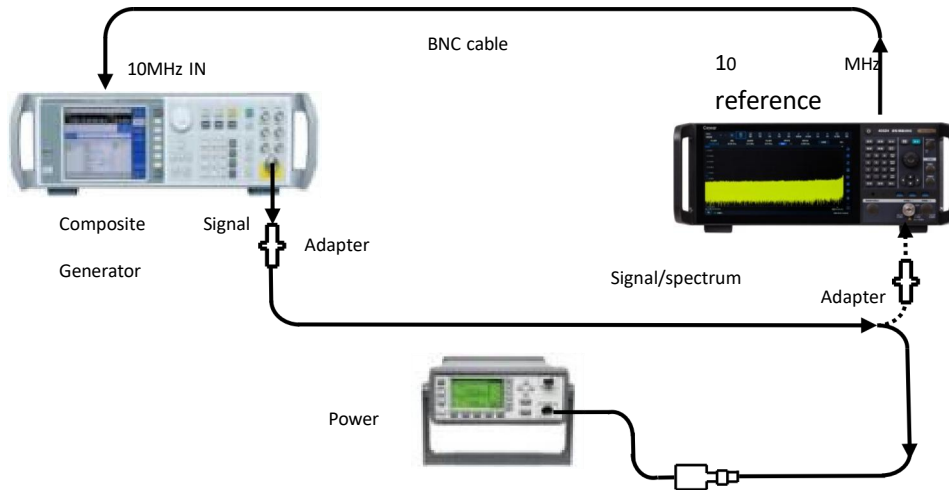

Figure 7.9 Diagram of the test on overall absolute amplitude precision

**7.5.1.17 Input voltage standing wave ratio**

a) Description of the test items

Impedance mismatch leads to the generation of reflected voltage. The incident voltage and reflected voltage transmit in both positive and negative directions, producing a certain interference pattern. The standing wave ratio is the ratio of the maximum to minimum value of the voltage graph envelope.

Directly use the standing wave ratio test function of the vector network analyzer to directly test the input voltage standing wave ratio of the input port of the signal/spectrum analyzer.

b) Test diagram and test instruments and equipment

Network analyzer .....Recommended N5247A/3672E

7.5 Performance characteristics test

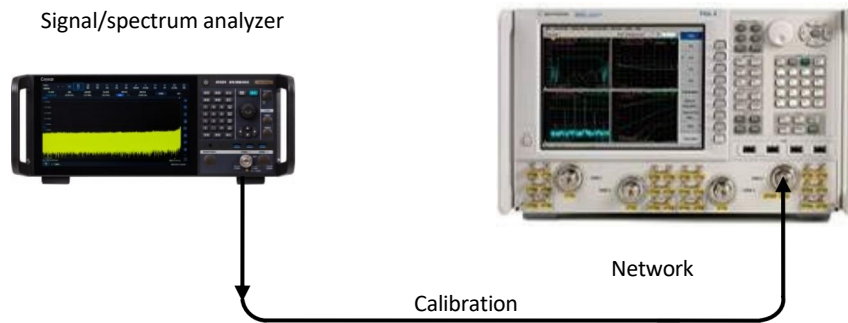

Figure 7.10 Input port voltage standing wave test

c) Test steps

- 1) Reset S4052, set the coupling method to DC coupling, and check to confirm that the input attenuator is set to 10dB;
- 2) Set the frequency range and source output power of network analyzer as appropriate parameters, and select VSWR display mode;
- 3) Select calibration cables for single port measurement calibration of the network analyzer (including open circuit, short circuit, and load calibration);
- 4) After the calibration, remove the calibration kit from the calibration cable and connect the test cable port to the input port of S4052, as shown in Figure 10;
- 5) Use the marker function to read the maximum voltage standing wave ratio (VSWR) of the corresponding frequency band of S4052 on the network analyzer.

d) Test record and data processing

Record measurement results in corresponding test items in **S4052 Records**.

7.5.1.18 Conversion Error of Resolution Bandwidth

a) Description of the test items

Due to configuration parameters, gain deviation may occur for the resolution bandwidth during conversion. Such errors are corrected during design of instruments. However, certain amplitude error exists due to factors such as calibration method and environmental change. Input a steady signal; change the S4052 resolution bandwidth; the peak amplitude deviation of the signal displayed on the signal/spectrum analyzer is the conversion error of resolution bandwidth.

Input a steady signal; change the S4052 resolution bandwidth; the peak amplitude deviation of the signal displayed on the signal/spectrum analyzer is the conversion error of resolution bandwidth.

b) Test steps

- 1) Reset S4052 and perform all calibration operations.
- 2) Set S4052 input to calibration port; set calibration source to 500 MHz; set the following parameters:
 

Center frequency.....	500 MHz
Span .....	1 MHz
Reference level.....	-18 dBm
Logarithmic scale dB/RAS .....	1 dB
Resolution bandwidth.....	300kHz

 Set VBW/RBW to 0.1.
- 3) Turn on the marker and perform a delta marker operation in S4052;

**7.5 Performance characteristics test**

- 4) According to resolution bandwidth in the corresponding test item in B.11 对应测试项中的分辨率带宽设置 S4052 of the S4052 Auxiliary Table, set the span to make the span approximately two times the resolution bandwidth.
  - 5) Record the marker difference reading as the conversion error of the current resolution bandwidth.
  - 6) Repeat steps 4 and step 5 for the other S4052 resolution bandwidth values in the corresponding test item in B.11 of the S4052 Auxiliary Table.
- c) Test record and data processing
- 1) Perform value judgment for all test items in B.11 of the S4052 Auxiliary Table. Find the positive maximum error  $\Delta A_{max}$  and the negative minimum error  $\Delta A_{min}$ ; Values of  $\Delta A_{max}$  and  $\Delta A_{min}$  are required to be within the conversion error range of S4052 resolution bandwidth; otherwise, record "Fail" therein.
  - 2) According to formula (14), calculate the conversion error of resolution bandwidth  $\Delta A$  and record the result in the S4052 Record Sheet.

$$\Delta A = \pm \frac{\Delta A_{max} - \Delta A_{min}}{2} \dots\dots\dots (14.)$$

**7.5.1.19 Ref Level**

- a) Description of the test items

The vertical scale position that has been calibrated on the signal/spectrum analyzer screen is used as the reference of amplitude measurement. The reference level usually refers to the top scale line. The reference level range and linear scale are guaranteed by the design. Reference level switching may cause a linkage of gain/attenuation. The reference level conversion error is used to assess the switching error of the IF gain of S4052. By changing the setting value of the standard attenuator, the error between the difference in marker readings caused by the S4052 reference level switching and the calibrated value of the standard attenuator is the reference level conversion error.

- b) Testing equipment

Composite signal generator —— E8257D/1465L is recommended

Standard attenuator ..... Recommended 84906L

Attenuator driver ..... Recommended 11713C

- c) Test steps

- 1) Connect the device as shown in Figure 11, reset S4052, and set S4052 to provide frequency reference for the signal generator. Set frequency of the signal generator to 30.02MHz; set its amplitude to -3 dBm.
- 2) Operate 11713C to control the standard attenuator 84906L with 0dB attenuation. And record the calibration values of the standard attenuator at the 30.02MHz frequency point in the S4052 Auxiliary Table;
- 3) S4052 performs reset operation, completes all calibration, waits for the end of calibration, and then sets as follows:
 

Center frequency.....	30.02 MHz
Span .....	1 MHz
Logarithm scale 1dB/RAS	
Resolution bandwidth .....	1kHz
Video bandwidth .....	30Hz
Attenuator Manual 10 dB	
- 4) Access [Measurement Settings], "More", and the measurement settings dialog box will pop up. Select "Advanced" and set the RF gain mode to "Sensitivity First". If not, you can leave it unset;
- 5) S4052 performs peak search and adjusts the output amplitude of the composite signal generator to make the signal 2-3 grids below the reference level of S4052;
- 6) S4052 performs a delta marker operation;
- 7) Set the S4052 to Trace Average ON, Average Times to 20.
- 8) Operate 11713C to control the standard attenuator 84906L with 10dB attenuation;
- 9) Set the S4052 reference level -10dBm according to the S4052 Auxiliary Table, perform a single sweep measurement, and wait for the sweep to complete;

7.5 Performance characteristics test

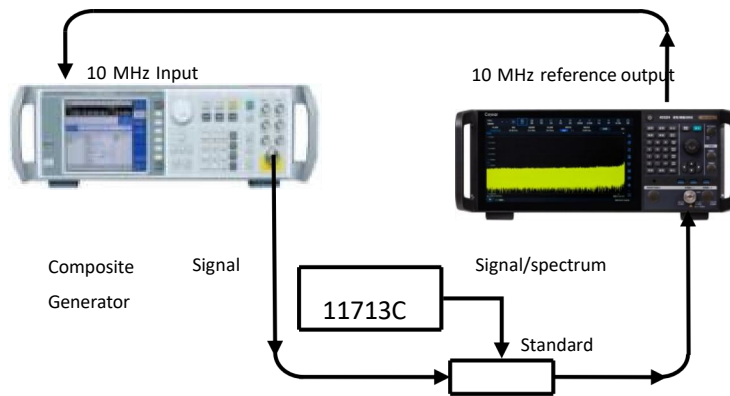

Figure 7.11 Schematic diagram of reference level conversion error testing

- 10) Record the S4052 delta marker amplitude reading  $\Delta L$  and record the test results in the S4052 Auxiliary Table B.12;
- 11) Repeat steps 8-10 based on the reference level parameters and standard attenuator settings in the S4052 Auxiliary Table B.12;
- 12) Calculate the corresponding reference level conversion error  $\Delta A_r$  according to Equation (15) and record it in the S4052 Record Sheet:

$$\Delta A_{ref} = \Delta L + A_{ATT} \dots\dots\dots (15.)$$

Where:

- $\Delta L$ - S4052 delta marker amplitude reading, in dB;
- $A_{ATT}$  - Calibration value of standard attenuator, in dB.

d) Test record and data processing

- 1) Perform value judgment for all test items in B.12 of the S4052 Auxiliary Table. Find the positive maximum error  $\Delta A_{ref\ max}$  and the negative minimum error  $\Delta A_{ref\ min}$ . The absolute values of the above two values are required to be within the conversion error range of S4052 reference level; otherwise, record "Fail" therein.
- 2) Calculate the reference level conversion error  $\Delta A$  according to Equation (16).

$$\Delta A = \pm \frac{\Delta A_{ref\ max} - \Delta A_{ref\ min}}{2} \dots\dots\dots (16.)$$

7.5.1.20 Display Scale Fidelity

a) Description of the test items

The display scale fidelity is the error between the vertical scale on the signal/spectrum analyzer screen and the theoretical value, which is used to assess the scale accuracy of S4052.

Set the scale to 10dB/grid, with a resolution bandwidth of 1kHz, and the input signal starting amplitude set to 0dBm reference level. When the signal amplitude is reduced, compare the displayed signal amplitude with the reference level. S4052 provides 10Mhz reference for signal generators.

b) Testing equipment

Composite signal generator —— E8257D/1465L is recommended

Standard attenuator..... Recommended 84906L

Attenuator driver..... Recommended 11713C

c) Test steps

- 1) Connect the device as shown in Figure 11, reset S4052, and set the signal generator as an external reference. Set frequency of the signal generator to 30.02MHz; set its output amplitude to 0dBm.
- 2) Operate 11713C to control the standard attenuator 84906L with 0dB attenuation. And record the calibration values of the standard attenuator at the 30.02MHz frequency point in the S4052 Auxiliary Table B.13;
- 3) S4052 performs reset operation, completes all calibration, waits for the end of calibration, and then sets as follows:  
Center frequency..... 30.02 MHz

**7.5 Performance characteristics test**

Span ..... 1 MHz  
 Resolution bandwidth ..... 1kHz  
 Video bandwidth ..... 30Hz

- 4) Adjust the output amplitude of the composite signal generator to ensure that the signal peak is at the reference level of S4052;
- 5) Set the S4052 to Trace Average ON, Average Times to 20.
- 6) S4052 performs peak search and difference marking;
- 7) Operate 11713C to control the standard attenuator 84906L with 10dB attenuation;
- 8) Set S4052 to perform single sweep measurement and wait for the sweep to complete;
- 9) Record the S4052 delta marker amplitude reading  $\Delta L$  and record the test results in the S4052 Auxiliary Table B.12;
- 10) Repeat steps 7-9 based on the standard attenuator settings in the S4052 Auxiliary Table B.13;
- 11) Calculate the corresponding display scale fidelity error  $\Delta A_V$  according to Equation (17) and record it in the S4052 Record Sheet:

$$\Delta A_V = \Delta L + A_{ATT} \dots \dots \dots (17.)$$

Where:

$\Delta L$ - S4052 delta marker amplitude reading, in dB;

$A_{ATT}$  - Calibration value of standard attenuator, in dB.

- d) Test record and data processing

- 1) Perform value judgment on all test items in the S4052 Auxiliary Table B.13 and find the positive maximum error value  $\Delta A_{Vmax}$  and negative minimum error value  $\Delta A_{Vmin}$ . It is required that the absolute values of these two error values are within the range of S4052 reference scale fidelity error; otherwise it is judged as non-compliant;
- 2) Calculate the display scale fidelity  $\Delta A$  according to Equation (18) and record it in the S4052 Record Sheet.

$$\Delta A = \pm \frac{\Delta A_{Vmax} - \Delta A_{Vmin}}{2} \dots \dots \dots (18.)$$

**7.5.1.21 Trace Detection**

- 1) Description of the test items

The detection method is a display method of signal energy. According to specific requirements, S4052 can provide a total of 7 detection methods including "normal, positive peak, negative peak, sampling, Video Average, Power Average, and Voltage Average". The detection method is guaranteed by the design.

- 2) Test steps

- 1) Reset S4052 and set to enter the second page of the trace menu. There are 5 detection modes that can be set, including normal, positive peak, sampling, negative peak, and average detection. Under average detection mode, there are three average types: video, power, and voltage. The default detection mode is normal detection mode;
- 2) By changing the S4052 detection method, the corresponding trace is changed and displayed according to the set detection method.

- 3) Test record and data processing

If steps 1 to 2 can complete the test correctly, it is judged that the trace detection method is normal and meets the indicator requirements. It is recorded as compliant in the S4052 Record Sheet; otherwise recorded as non-compliant.

**7.5.1.22 1 dB gain compression**

- a) Description of the test items

When the input signal level increases, the signal/spectrum analyzer mixer, amplifier and other unit circuits can approach the saturation operating point. At this time, the output signal component no longer changes linearly with the input signal. Typically, the level value corresponding to an output deviation of 1 dB below the linear value is expressed as a 1 dB compression point.

Input a low-power signal into the signal/spectrum analyzer, and then input a high-power signal with a frequency interval of 3MHz into the signal/spectrum analyzer. Change the power of the high-power signal until the high-power signal causes a 1dB change in the measured power of the low-power signal. At this point, the power value of the high-power signal is converted to the input port level of the mixer, which is the 1dB gain compression level.

**7.5 Performance characteristics test**

B) Test equipment

Power meter: 2434/E4418B is recommended.

Composite signal generator #1—— E8257D/1465L is recommended

Composite signal generator #2—— E8257D/1465L is recommended

Power sensor: N8487A/R&SZ61 is recommended

Directional bridge coupler.....Recommended 80622HA

c) Test steps

**Gain compression (10MHz - 100MHz)**

- 1) Complete zero and calibration of the power meter;
- 2) Reset S4052, set the center frequency to 10MHz, span to 1kHz, reference level 0dBm, and attenuator 0dB; Access [Sweep], "More", and a sweep dialog box will pop up. Set the FFT width to "less than 10kHz";
- 3) Set the frequency of composite signal generator 1# to 13MHz and the frequency of composite signal generator 2# to 10MHz, with an output power of -10dBm, and turn off the output of composite signal generator 2#;
- 4) Connect the instrument as shown by the solid line in Figure 12. Signal generator 1 is connected to the direct input of the directional coupler, signal generator 2# is connected to the coupling port of the directional coupler, and the output of the directional coupler is connected to the power meter sensor through an adapter;
- 5) Set the testing frequency of the power meter to the output frequency value of signal generator 1#. Adjust the output power level of signal generator 1# to make the reading of the power meter at this time equal to the mixer level when compressing the 1dB gain of the current test frequency band, and turn off the output of signal generator 1#;
- 6) Change the test connection relationship according to the dashed line position shown in Figure 12. Turn on the output of the composite signal generator 2#, adjust the power level of the composite signal generator 2# to make the signal peak at -20 to -23dBm;
- 7) S4052 performs peak search and opens the S4052 delta marker function;
- 8) Turn on the output of composite signal generator 1#; Read the amplitude value of the marker difference reading at this time. If the absolute value of the amplitude value at this time is less than 1dB, record the difference reading amplitude value in the S4052 Record Sheet, judged as compliant; otherwise judged as non-compliant;
- 9) Turn off the output of composite signal generator #1;

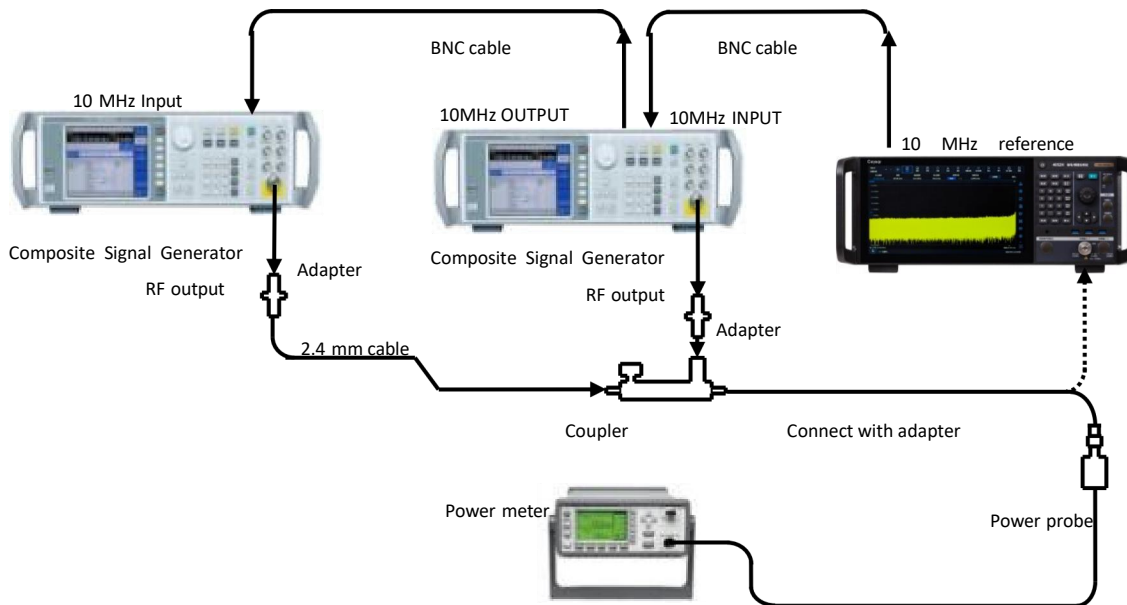

Figure 7.12 1dB gain compression test

**Gain compression (10MHz - 100MHz)**

- 10) Connect the instrument according to the solid line in Figure 12. Set the center frequency of S4052 to 100MHz, the frequency of composite signal generator 1# to 103MHz, and the frequency of composite signal generator 2# to 100MHz;

**7.5 Performance characteristics test**

- 11) Repeat steps 5) to 8);

**7.5 Performance characteristics test**

- 12) Turn off the output of composite signal generator #1;

**Gain compression (10MHz - 100MHz)**

- 13) Connect the instrument according to the solid line in Figure 12. Set the center frequency of S4052 to 100MHz, the frequency of composite signal generator 1# to 103MHz, and the frequency of composite signal generator 2# to 100MHz;
- 14) Repeat steps 5) to 8);
- 15) Turn off the output of composite signal generator #1;

**Gain compression (10MHz - 100MHz)**

- 16) Connect the instrument according to the solid line in Figure 12. Set the center frequency of S4052 to 100MHz, the frequency of composite signal generator 1# to 103MHz, and the frequency of composite signal generator 2# to 100MHz;
- 17) Replace the RF directional coupler with a millimeter wave directional coupler;
- 18) Repeat steps 5) to 8);
- 19) Turn off the output of composite signal generator #1;

**Gain compression (10MHz - 100MHz)**

- 20) Connect the instrument according to the solid line in Figure 12. Set the center frequency of S4052 to 100MHz, the frequency of composite signal generator 1# to 103MHz, and the frequency of composite signal generator 2# to 100MHz;
- 21) Repeat steps 5) to 8);
- 22) Turn off the output of composite signal generator #1;

**7.5.1.23 Explicit average noise level**

## a) Description of the test items

The explicit average noise level refers to the background noise observed by the signal/spectrum analyzer when there is no additional noise or signal.

The display average noise level test value is shown by the normalized noise value observed in the absence of applied noise or signal and with minimum input attenuation. When the test peak is the residual response, this test frequency point should be avoided.

## B) Test equipment

50  $\Omega$  load

## c) Test steps

**Displayed average noise (10 MHz to 1 GHz)**

- 1) According to Figure 13, connect the 50 ohm load and the adapter to the input port of the S4052.
- 2) Reset S4052 and set the following parameters:

Starting frequency ..... 10MHz

Ending frequency ..... 3MHz

Reference level ..... -40 dBm

Mechanical attenuator 0 dB

Set the detection method to power average; The refresh method is average, with an Average Times of 10;

If the Pre-amplifier option is provided, set it to OFF.

7.5 Performance characteristics test

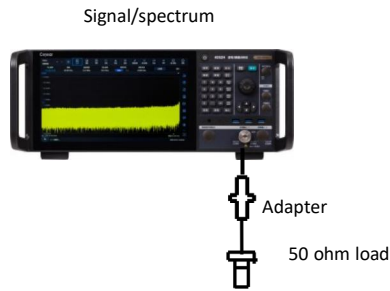

Figure 7.13 Diagram of the test on the displayed average noise

- 3) Set S4052 peak search; set Peak to the center frequency; enable the noise marker function; set the following parameters: Span

..... 1 MHz  
 Reference level ..... -80 dBm

Single measurement

- 4) Read the marker amplitude value; if the reading at this time is smaller than or equal to the specified value for the S4052, record the reading as the displayed average noise level of the band (10 MHz to 1 GHz) in the corresponding test item in the S4052 Record Sheet. Otherwise, record "Fail" therein.

**Displayed average noise (1 GHz to 2 GHz)**

- 5) Set S4052:

Reference level ..... -40 dBm  
 Starting frequency ..... 1GHz  
 Ending frequency ..... 3MHz

- 6) Repeat steps 3) to 4);

- 7) Read the marker amplitude value; if the reading at this time is smaller than or equal to the specified value for the S4052, record the reading as the displayed average noise level of the band (1 GHz to 2 GHz) in the corresponding test item in the S4052 Record Sheet. Otherwise, record "Fail" therein.

**Displayed average noise (2 GHz to 3 GHz)**

- 8) Set S4052:

Reference level ..... -50 dBm  
 Starting frequency ..... 2GHz  
 Ending frequency ..... 3MHz

- 9) Repeat steps 3) to 4);

- 10) Read the marker amplitude value; if the reading at this time is smaller than or equal to the specified value for the S4052, record the reading as the displayed average noise level of the band (2 GHz to 3 GHz) in the corresponding test item in the S4052 Record Sheet. Otherwise, record "Fail" therein.

**Displayed average noise (3 GHz to 4 GHz)**

- 11) Set S4052:

Reference level ..... -50 dBm  
 Starting frequency ..... 3GHz  
 Ending frequency ..... 3MHz  
 Mechanical attenuator 0 dB

Set the detection method to power average; The refresh method is average, with an Average Times of 10;

- 12) Repeat steps 3) to 4);

- 13) Read the marker amplitude value; if the reading at this time is smaller than or equal to the specified value for the S4052, record the reading as the displayed average noise level of the band (3 GHz to 4 GHz) in the corresponding test item in the S4052 Record Sheet. Otherwise, record "Fail" therein.

**7.5 Performance characteristics test**

**Displayed average noise (4 GHz to 6 GHz)**

**7.5 Performance characteristics test**

14) Set S4052:

Reference level ..... -50 dBm  
 Starting frequency ..... 4GHz  
 Ending frequency ..... 3MHz  
 Mechanical attenuator 0 dB

Set the detection method to power average; The refresh method is average, with an Average Times of 10;

15) Repeat steps 3) to 4);

16) Read the marker amplitude value; if the reading at this time is smaller than or equal to the specified value for the S4052, record the reading as the displayed average noise level of the band (4 GHz to 5 GHz) in the corresponding test item in the S4052 Record Sheet. Otherwise, record "Fail" therein.

**Displayed average noise (6 GHz to 8 GHz)**

17) Set S4052:

Reference level ..... -50 dBm  
 Starting frequency ..... 6GHz  
 Ending frequency ..... 3MHz

18) Repeat steps 3) to 4);

19) Read the marker amplitude value; if the reading at this time is smaller than or equal to the specified value for the S4052, record the reading as the displayed average noise level of the band (6 GHz to 8 GHz) in the corresponding test item in the S4052 Record Sheet. Otherwise, record "Fail" therein.

**Displayed average noise (8 GHz to 18 GHz)**

20) Set S4052:

Reference level ..... -30 dBm  
 Starting frequency ..... 8GHz  
 Ending frequency ..... 3MHz

21) Repeat steps 3) to 4);

22) Read the marker amplitude value; if the reading at this time is smaller than or equal to the specified value for the S4052, record the reading as the displayed average noise level of the band (8 GHz to 18 GHz) in the corresponding test item in the S4052 Record Sheet. Otherwise, record "Fail" therein.

**Displayed average noise (18 GHz to 26.5 GHz)**

23) Set S4052:

Reference level ..... -30 dBm  
 Starting frequency ..... 18GHz  
 Ending frequency ..... 3MHz

24) Repeat steps 3) to 4);

25) Read the marker amplitude value; if the reading at this time is smaller than or equal to the specified value for the S4052, record the reading as the displayed average noise level of the band (8 GHz to 18 GHz) in the corresponding test item in the S4052 Record Sheet. Otherwise, record "Fail" therein.

**Displayed average noise (26.5 GHz to 40 GHz)**

26) Set S4052:

Reference level ..... -30 dBm  
 Starting frequency ..... 26.5GHz  
 Ending frequency ..... 3MHz

27) Repeat steps 3) to 4);

28) Read the marker amplitude value; if the reading at this time is smaller than or equal to the specified value for the S4052, record the reading as the displayed average noise level of the band (8 GHz to 18 GHz) in the corresponding test item in the S4052 Record Sheet. Otherwise, record "Fail" therein.

**Displayed average noise (40 GHz to 50 GHz)**

29) Set S4052:

**7.5 Performance characteristics test**

Reference level ..... -30 dBm  
 Starting frequency ..... 40GHz  
 Ending frequency ..... 3MHz

- 30) Repeat steps 3) to 4);  
 31) Read the marker amplitude value; if the reading at this time is smaller than or equal to the specified value for the S4052, record the reading as the displayed average noise level of the band (8 GHz to 18 GHz) in the corresponding test item in the S4052 Record Sheet. Otherwise, record "Fail" therein.

**Displayed average noise (pre-amplifier enabled)**

- 32) If the pre-amplifier option is provided, perform operations by referring to step 1 to step 31; in step 2, enable the pre-amplifier.

**7.5.1.24 Residual response**

a) Description of the test items

Residual response indicates the discrete response observed on the display when the signal/spectrum analyzer does not receive any input signal.

b) Testing steps

- 1) Connect the instrument as per Figure 13. Reset S4052; connect the signal input port to the 50 ohm load. Set S4052 as follows: Center frequency.....  
**15.2 MHz Frequency step 28.5MHz.**

Span ..... 1 MHz  
 Reference level ..... -50 dBm  
 Attenuator 0 dB  
 Resolution bandwidth ..... 10kHz

- Set RF Gain to Sensitivity Priority.  
 2) Turn on the display line and set it at -90dBm. The signal peak should be at least 6dB below the display line; If not, it is necessary to reduce the resolution bandwidth and span to reduce the noise level, which will result in an extension of the testing cycle; If the span is reduced, reduce the frequency step to no more than 95% of the span; If the zero frequency signal causes the amplitude of the starting point signal to be higher than -96dBm, it is necessary to adjust the start frequency point with a knob to make the noise level lower than -96dBm;  
 3) Record the maximum response frequency and amplitude of the current trace in B14 of the S4052 Auxiliary Table.  
 4) If you suspect that residual response exists, press Single Sweep again. Residual response continues to appear; the noise peak disappears; do not record the noise as residual response.  
 5) Set S4052 frequency step once; after the trace is refreshed, compare the maximum response amplitude of the current trace with the previous maximum response; retain the maximum value between the two.  
 6) Check the residual response of frequency 8 GHz by referring to step 2 to step 5; record the tested maximum response in measured results for 200 kHz to 8 GHz in B.14 of the S4052 Auxiliary Table.

c) Test record and data processing

Perform value judgment for the final test results in B.14 of the S4052 Auxiliary Table. The maximum response shall be smaller than or equal to the specified value for S4052 Residual Response; record the result in the S4052 Record Sheet. Otherwise, record "Fail" therein.

**7.5.1.25 Second harmonic distortion**

Description of the test items

When a signal is input to a nonlinear device (such as a mixer, amplifier, etc.), the nonlinear device will generate various harmonics of the input signal. The unwanted second harmonic component attached to the signal is called second harmonic distortion.

The second harmonic distortion value can be obtained by inputting the sine wave signal as pure as possible (realized by external filter) into the signal/spectrum analyzer and testing the second harmonic component caused by the signal passing through the signal/spectrum analyzer.

Test diagram and test instruments and equipment

Composite signal generator — E8257D/1465L is recommended

One 1.6 GHz low-pass filter

One 4 GHz low-pass filter

One 9 GHz low-pass filter

One 26.5 GHz low-pass filter

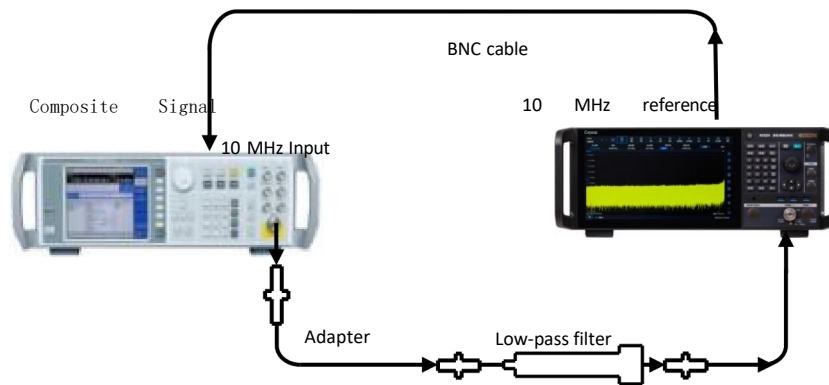

Figure 7.14 Second harmonic distortion test

#### Test procedure

##### Second harmonic distortion (10MHz - 2GHz)

Connect the instrument using a 1.6GHz low-pass filter and BNC cable as shown in Figure 14. A frequency reference is provided by the S4052 for the composite signal generators, and the signal generator is recognized as an external reference. Reset the composite signal generator frequency to 1.6GHz, the amplitude to -15 dBm and the RF output ON; Reset S4052 and set the following parameters:

Center frequency..... 1.6 GHz  
 Span ..... 1 MHz  
 Reference level ..... -15 dBm  
 Attenuator 0 dB

Set peak search and adjust the power level of the composite signal generator to make the reading of S4052 closest to

-15dBm.

Set S4052 single sweep and wait for the sweep to end. Set peak search, marker → step, then delta marker, and step frequency once. Set S4052 single sweep function.

Peak search after S4052 completes a new sweep. Record the Delta Marker reading in the S4052 Record Sheet as the second harmonic distortion product of the current test frequency band.

##### Second harmonic distortion (10MHz - 2GHz)

Connect the instrument as shown in Figure 14, and use 4GHz low-pass filter.

Set the frequency of the composite signal generator to 4 GHz; set the amplitude to -15 dBm.

Set S4052 as follows:

**7.5 Performance characteristics test**

Center frequency ..... 4 GHz  
 Marker ..... Disable all markers  
 Repeat steps 4) ~ 6).

**Second harmonic distortion (4GHz - 9GHz)**

Connect the instrument as shown in Figure 14, and use 4GHz low-pass filter.  
 Set the frequency of the composite signal generator to 4 GHz; set the amplitude to -15 dBm.  
 Set S4052 as follows:

Center frequency ..... 8 GHz  
 Marker ..... Disable all markers  
 Repeat steps 4) ~ 6).

**Second harmonic distortion (4GHz - 9GHz)**

Connect the instrument as shown in Figure 14, and use 4GHz low-pass filter.  
 Set the frequency of the composite signal generator to 4 GHz; set the amplitude to -15 dBm.  
 Set S4052 as follows:

Center frequency ..... 20 GHz  
 Marker ..... Disable all markers  
 Repeat steps 4) ~ 6).

**7.5.1.26 Third-order intermodulation distortion**

a) Description of the test items

Third-order intermodulation distortion is a useless frequency component formed by the interaction of the spectral components of two or more input signals due to the nonlinearity of the device.

Two signal generators are used to produce two sinusoidal signals with a frequency interval of 50 kHz and the same power for simultaneous input into a signal/spectrum analyzer. Use the frequency marker function of the signal/spectrum analyzer to directly measure third-order intermodulation distortion products.

b) Test diagram and test instruments and equipment

Power meter: 2434/E4418B is recommended.

Power sensor: 71712A/N8487A is recommended.

Composite signal generator #1 — E8257D/1465L is recommended

Composite signal generator #2 — E8257D/1465L is recommended

Isolator ..... Recommended CTP-3060

Isolator ..... Recommended XTP-1218A

Millimeter wave directional coupler ..... Recommended 70603

RF directional coupler

50 MHz low-pass filters

50 MHz low-pass filters

c) Test steps

**Third order intermodulation distortion (10MHz - 200MHz)**

- a) After zeroing and calibrating the power meter, set the frequency to 50 MHz;
- b) Connect the instrument according to the solid line in Figure 15;
- c) Set the frequency of the composite signal generator #1 to 50 MHz, the amplitude to +5dBm, and the amplitude step to 0.05dB;
- d) Reset the composite signal generator #2 and set the frequency to 50.05 MHz, the power to -110 dBm and the RF output OFF;
- e) Reset S4052 and set the IF of S4052 to 50MHz;
- f) Set S4052:

**Frequency step 50kHz.**

Span ..... 1 MHz  
 Reference level ..... 0 dBm

## 7.5 Performance characteristics test

Attenuator 0 dB

- g) Access [Sweep], "More", and a sweep dialog box will pop up. Set the FFT width to "less than 10kHz";
- h) Adjust the output amplitude of the composite signal generator #1 so that the display reading of the power meter is most close to -10dbm;
- i) Remove the power sensor from the RF directional coupler. Connect the RF directional coupler directly to the S4052 input port with an adapter;
- j) Set S4052 peak search and marker → reference. Wait for a new sweep to complete, perform the delta marker operation, and step up the frequency once;

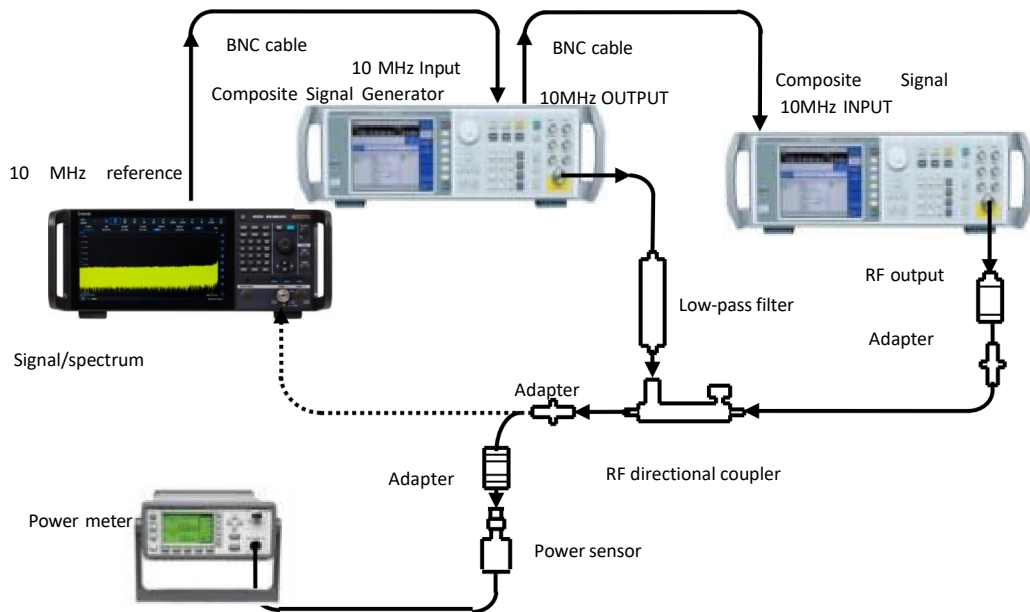

**7.5 Performance characteristics test**

Figure 7.15 Third-order intermodulation distortion test (10MHz-4GHz)

- k) Turn on the RF output of composite signal generator #2, and the power to -10dBm;
- l) Set S4052 peak search;
- m) Adjust the power level of composite signal generator #2 so that the delta marker reading of S4052 is most close to 0dB;
- n) Set the S4052 Delta Marker, step down the center frequency twice, and wait for the new sweep to complete; Set the Video Average to 5 times and perform trace average, single measurement, and wait for the Video Average to display on the grid; Peak search, at which point the S4052 Delta Marker reading is the low-end product of intermodulation distortion, recorded in the S4052 Record Sheet;
- o) Step up the center frequency of S4052 three times, and perform peak search after completing a single measurement; At this point, the reading of the S4052 Delta Marker is a high-end product of intermodulation distortion, recorded in the S4052 Record Sheet;

**Third order intermodulation distortion (10MHz - 200MHz)**

- p) Set frequency of composite signal generator #1 to 1.5GHz and power to +5dBm; set RF Output to ON.
- q) Set frequency of composite signal generator #2 to 1.50005GHz and signal power to -110dBm; set RF output OFF;
- r) Set power meter frequency to 1.5 GHz;
- s) Reset S4052 and set the center frequency to 1.5GHz;
- t) Repeat steps 6) ~ 15).

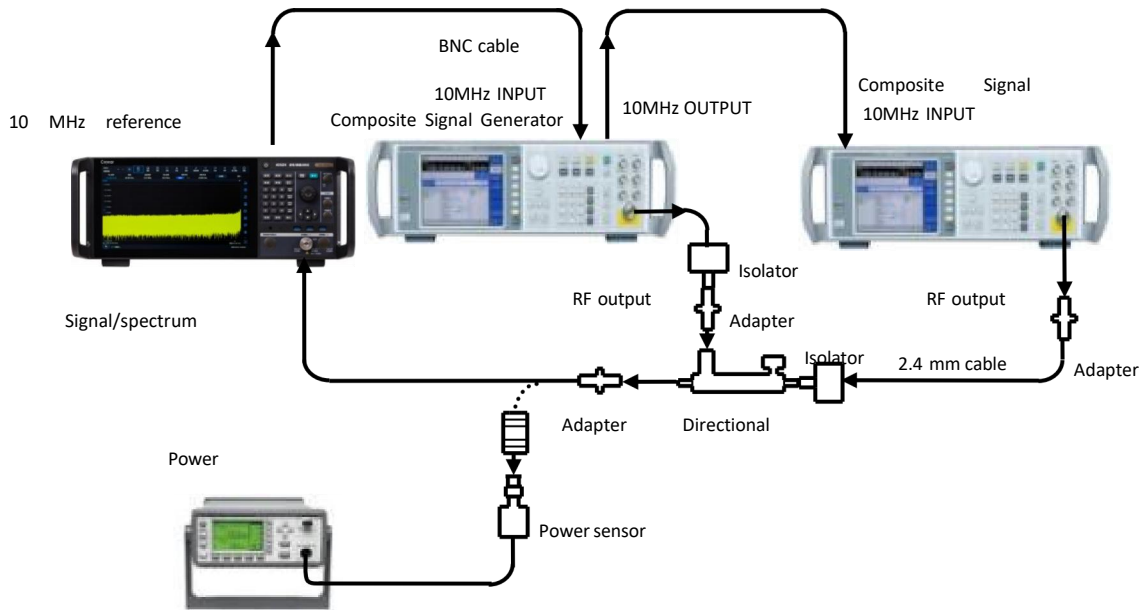

Figure 7.16 Third-order intermodulation distortion test (4 GHz-67 GHz)

**Third order intermodulation distortion (10MHz - 200MHz)**

- u) Connect the instrument as shown in Figure 16 and replace the RF directional coupler in Figure 16 with a millimeter wave directional coupler;
- v) Set frequency of composite signal generator #1 to 5GHz and power to +5dBm; set RF Output to ON.
- w) Set frequency of composite signal generator #2 to 5.00005GHz and signal power to - 110dBm; set RF output OFF;
- x) Set power meter frequency to 5 GHz;
- y) Reset S4052 and set the center frequency to 5GHz;
- z) Repeat steps 6) ~ 15).

**Third order intermodulation distortion (10MHz - 200MHz)**

- aa) Set frequency of composite signal generator #1 to 10GHz and power to +5dBm; set RF Output to ON.
- bb) Set frequency of composite signal generator #2 to 10.00005GHz and signal power to - 110dBm; set RF output OFF;
- cc) Set power meter frequency to 35 GHz;
- dd) Reset S4052 and set the center frequency to 10GHz; ee) Repeat steps 6) ~ 15).

**Third order intermodulation distortion (10MHz - 200MHz)**

- ff) Set frequency of composite signal generator #1 to 35GHz and power to +5dBm; set RF Output to ON.
- gg) Set frequency of composite signal generator #2 to 35.00005GHz and signal power to - 110dBm; set RF output OFF;
- hh) Set power meter frequency to 35 GHz;
- ii) Reset S4052 and set the center frequency to 35GHz; jj) Repeat steps 6) ~ 15).
- d) Test record and data processing
  - 1) Select the maximum value of the third-order intermodulation distortion product  $\Delta A$  at the mixer level of  $L_0$  (-10dBm) from the high and low intermodulation distortion products at the same frequency point. Calculate the third order intercept point (TOI) according to Equation (19).

$$TOI = L_0 - \frac{\Delta A}{2} \dots\dots\dots (19.)$$

**7.5.1.27 Phase Noise**

- a) Description of the test items

**7.5 Performance characteristics test**

Phase noise is an indicator to represent the short-term stability of the LO signal frequency of the signal/spectrum analyzer. Measure the single sideband phase noise at the frequency offset of 1GHz, 100Hz, 1kHz, 10kHz, 100kHz, and 1MHz on the carrier. In order to reduce the measurement error, the phase noise index at each frequency offset of the input carrier signal shall be at least 6dB-10dB higher than that of the signal/spectrum analyzer. During the testing process, if there is a parasitic response at the set frequency offset, it should be removed and measured near the frequency offset.

**B) Test equipment**

Composite signal generator..... Recommended E8257D (including high-purity options) or specialized test tooling

**c) Test steps**

a) Connect the instrument as shown in Figure 17 and set the signal generator as follows;

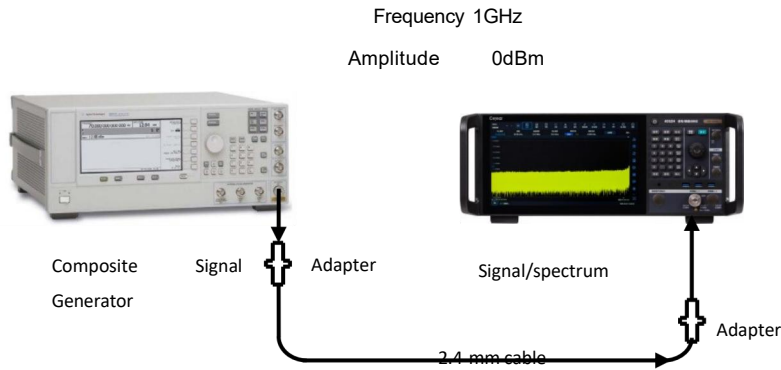

Figure 7.17 Schematic diagram of phase noise test

- b) Reset S4052 and set the center frequency to 1GHz with a span of 100kHz; Reference level 0dB, attenuator 0dB, access [Measurement Settings], "More", pop up the measurement settings dialog box, select "Advanced", set the RF gain mode to "Sensitivity Priority"; Detection method: power average; Display method: average; Average frequency: 50; Noise marker ON;
- c) Reduce the span of S4052 and place the signal in the center of the screen, ultimately setting the bandwidth to 200Hz;
- d) Peak search, delta marker, set delta marker to 100Hz, single measurement; After the measurement is completed, read the difference amplitude value of the noise mark at the frequency offset 100Hz point as the phase noise at the +100Hz deviation point;
- e) Set the Delta Marker to -100Hz. After a single measurement, read the difference of the noise marker at the point of frequency deviation -100Hz as the phase noise at the deviation of -100Hz. Take the maximum value between the two as the phase noise at the frequency deviation of 100Hz and record it in the S4052 Record Sheet;
- f) Set the span of S4052 to 2kHz, 20kHz, 200kHz, and 2MHz in sequence, and test the phase noise at the deviation points of  $\pm 1\text{kHz}$ ,  $\pm 10\text{kHz}$ ,  $\pm 100\text{kHz}$ , and  $\pm 1\text{MHz}$  according to steps 4) to 5).

**7.5.1.28 IQ Data**

IQ byte length: 32-bit I, 32-bit Q, guaranteed by the design; Each pair of IQ data occupies 8 Bytes. In IQ analysis mode, select the current maximum analysis bandwidth, set the IQ data length to the maximum, and click Save. The saved IQ data size should not be less than 3.73GB. It is recorded as compliant.

**7.5.1.29 Mirror Response**

**a) Description of the test items**

During frequency mixing, two input signals can generate the same IF signal with that of the LO signal with the same frequency, with one signal frequency one IF lower than the LO and another signal frequency one IF higher than the LO. In this case, one of the signal is called the mirror frequency of the other. Each frequency of the LO has a mirror frequency of corresponding input signal, with the difference of two IFs between the signal and the mirror frequency.

The input signal is set to the same center frequency as S4052, and the reference amplitude is measured. Then, the composite signal generator is tuned to a frequency that can cause mirror, multiple, or out-of-band response. The difference in signal amplitude displayed on S4052 is measured and recorded as the mirror response.

**7.5 Performance characteristics test**

## b) Testing equipment

Composite signal generator — E8257D and 1464 are recommended

## c) Test steps

**Third IF mirror response**

- 1) Connect the test equipment as shown in Figure 8. Reset the S4052.
- 2) Set the frequency of the composite signal generator to 1GHz, the power to -4dBm, the center frequency of S4052 to 1GHz, and the testing frequency of the power meter to 1GHz.
- 3) Set S4052 as follows:
 

Span .....	1 MHz
Reference level .....	0 dBm
Attenuator	0 dB
Resolution bandwidth .....	100Hz
Video bandwidth .....	10kHz
- 4) Adjust the power level of the composite signal generator to make the power meter reading closest to -10dBm.
- 5) S4052 performs peak search and Delta marking.
- 6) Set the frequency of the composite signal generator and power meter to the frequency point listed in the S4052 Record Sheet that corresponds to the occurrence of the third IF mirror response.
- 7) Adjust the output amplitude of the composite signal generator to make the power meter reading to be most close to -10dBm;
- 8) Record the amplitude value of the Delta Marker in the corresponding test item of the S4052 Record Sheet.
- 9) Set S4052, composite signal generator, and power meter according to the frequency points listed in the S4052 Record Sheet, and repeat steps 4 to 8.

**Second IF mirror response**

- 10) Set the frequency of the composite signal generator to 1GHz, the power to -4dBm, the center frequency of S4052 to 1GHz, and the testing frequency of the power meter to 1GHz.
- 11) S4052 performs peak search and Delta marking.
- 12) Set the frequency of the composite signal generator and power meter to the frequency point listed in the S4052 Record Sheet that corresponds to the occurrence of the second IF mirror response.
- 13) Adjust the output amplitude of the composite signal generator to make the power meter reading to be most close to -10dBm;
- 14) Record the amplitude value of the Delta Marker in the corresponding test item of the S4052 Record Sheet.
- 15) Set S4052, composite signal generator, and power meter according to the frequency points listed in the S4052 Record Sheet, and repeat steps 11 to 14.

**First IF mirror response**

- 16) Set the frequency of the composite signal generator to 1GHz, the power to -4dBm, the center frequency of S4052 to 1GHz, and the testing frequency of the power meter to 1GHz.
- 17) S4052 performs peak search and Delta marking.
- 18) Set the frequency of the composite signal generator and power meter to the frequency point listed in the S4052 Record Sheet that corresponds to the occurrence of the first IF mirror response.
- 19) Adjust the output amplitude of the composite signal generator to make the power meter reading to be most close to -10dBm;
- 20) Record the amplitude value of the Delta Marker in the corresponding test item of the S4052 Record Sheet.

Set S4052, composite signal generator, and power meter according to the frequency points listed in the S4052 Record Sheet, and repeat steps 17 to 21.

## 7.5 Performance characteristics test

### 7.5.2 Interfaces

#### 7.5.2.1 RF Input Interface

The signal input interface should comply with the requirements specified in 3.13.1 of this manual. The connector should be installed flexibly, conveniently, and in place.

#### 7.5.2.2 Communication Interface

The number of communication interface types should comply with the provisions of 3.13.2 of this manual and the following requirements:

- a) USB interface on the front panel: install a USB mouse. After being recognized by the system, slide the mouse and the marker moves normally.
- b) LAN interface: Use a host computer with a LAN interface to connect to the device under test through a LAN cable, and input "IDN?" in the programmable operator interface software of the host computer. The device under test should be able to return device information.
- c) 10 Gigabit Ethernet interface (option): Use the host computer with a 10GE fiber optic interface, connect it to the device under test through a 10GbE fiber optic cable, and input "IDN?" in the programmable operator interface software of the host computer. The device under test should be able to return device information.
- d) GPIB interface: use USB-GPIB cable to connect the spectrum analyzer and the host computer. The spectrum analyzer should be able to return device information by entering "IDN?" into the programmable operator interface software of the host computer.

#### 7.5.2.3 Audio and Video Interface

The audio and video interface should comply with the provisions of 3.13.3 of this manual and the following requirements:

- a) Earphone interface: standard 3.5 mm. Connect the earphones to the earphonejack. Use the player in the system to play a sound file. At this point, clear sound should be heard in the earphones;
- b) Video interface: DP (Display Port) display interface, connected to a liquid crystal display through a DP data cable (resolution should not be less than 1920 \* 1080), can display instrument panel information normally.

#### 7.5.2.4 Time Base Interfaces

The time base interface should comply with the provisions of 3.13.4 of this manual and the following requirements:

- a) 10MHz reference input: Visual inspection of interface type. Use two composite signal generators for testing and verification. Connect the RF output of composite signal generator 1# to the signal input port of the device under test, set the output frequency of the signal generator to 1GHz with an amplitude of -10dBm, and set the center frequency of the device under test to 1GHz with a span of 1kHz. Set the output frequency of composite signal generator 2# to point 10MHz with an amplitude of -5dBm, and connect the RF output to the "10MHz reference input" of the device under test. Set the device under test as an external 10MHz reference and use the marker function to adjust the signal to the center of the screen of the device under test. Fine tune the output frequency of composite signal generator 2#, such as changing 0.1Hz. At this time, the signal frequency value displayed by the device under test should change by about 10Hz, indicating that the external reference of the device under test is locked. Change the amplitude output of the composite signal generator until +10dBm, and the device under test should always be in a locked state.
- b) 100MHz reference input: Visual inspection of interface type. Use two composite signal generators for testing and verification. Connect the RF output of composite signal generator 1# to the signal input port of the device under test, set the output frequency of the signal generator to 1GHz with an amplitude of -10dBm, and set the center frequency of the device under test to 1GHz with a span of 1kHz. Set the output frequency of composite signal generator 2# to point 100MHz with an amplitude of -5dBm, and connect the RF output to the "100MHz reference input" of the device under test. Set the device under test as an external 10MHz reference and use the marker function to adjust the signal to the center of the screen of the device under test. Fine tune the output frequency of composite signal generator 2#, such as changing 0.1Hz. At this time, the signal frequency value displayed by the device under test should change by about 10Hz, indicating that the external reference of the device under test is locked. Change the amplitude output of the composite signal generator until +10dBm, and the device under test should always be in a locked state.
- c) 10MHz reference output: Visual inspection of interface type. Test with S4052F spectrum analyzer. Connect the "10MHz reference output" of the DUT to the signal input of the S4052F Spectrum Analyzer and test the 10MHz signal amplitude, which should be greater than 0dBm.

**7.5 Performance characteristics test**

- d) 100MHz reference output: Visual inspection of interface type. Test with S4052F spectrum analyzer. Connect the "10MHz reference output" of the DUT to the signal input of the S4052F Spectrum Analyzer and test the 10MHz signal amplitude, which should be greater than 0dBm.

**7.5.2.5 Trigger Interface**

The trigger interface should comply with the provisions of 3.13.5 of this manual and the following requirements:

- a) Trigger Input 1: Visual inspection of interface type. Please refer to the testing section of 4.6.15.7 External Trigger for the functional inspection method.
- b) Trigger Input 2: Visual inspection of interface type. Please refer to the testing section of 4.6.15.7 External Trigger for the functional inspection method.
- c) Trigger Output 1: Visual inspection of interface type. Set the device under test in spectrum analysis mode, set Trigger Output 1 to On through the Input/Output menu, and select the output signal as the sweep control signal. Connect the Trigger Output 1 port to the oscilloscope input port via a BNC cable and the corresponding digital pulse signal should be observed.
- d) Trigger Output 2: Visual inspection of interface type. Set the device under test in spectrum analysis mode, set Trigger Output 2 to On through the Input/Output menu, and select the output signal as the sweep control signal. Connect the Trigger Output 2 port to the oscilloscope input port via a BNC cable and the corresponding digital pulse signal should be observed.

**7.5.3 Performance Test Recording Sheet**

Table 7.2 Record sheet of S4052A/B signal/spectrum analyzer function performance test (Group A) (Type )

Instrument No.:

Test Personnel:

Test Condition:

Test Date:

No.	Test Item	Unit	Standard Requirement	Test result
1	Appearance	/	The appearance shall be clean and tidy, and the surface shall be free of rust, mildew, stains, peeling of plating coating and obvious scratches and burrs; plastic parts shall be free of bubble, crack or deformation; characters, symbols, marks and various signs shall be clean and firm. Structure members and control parts shall be integrate and free of any mechanical damage.	

7.5 Performance characteristics test

No.	Test Item		Unit	Standard Requirement	Test result
2	Function	Functional normality	/	After power on, it can work normally, and there is no fault prompt during self inspection, with clear display. The positioning of keys, switches, knobs, and connectors should be correct, with clear connections, flexible rotation, and firm installation.	
		Main Functions	/	Spectrum analysis measurement function, supporting continuous sweep, FFT step sweep, gated sweep and other sweep methods	
	Power kit measurement function, supporting power measurement functions such as channel power, occupied bandwidth, adjacent channel power, power statistics, burst power, spurious emission, Spectrum Emission Mask, harmonic distortion, third-order intermodulation, etc				
	IQ analysis				
	Self testing and self calibration function, supporting internal state monitoring function				
			Support remote control functions such as GPIB and LAN		
3	Frequency range:		/	DC coupling: 2Hz - upper limit of model frequency range	
				AC coupling: 10MHz - upper limit of model frequency range	
4	Frequency reference		/	Frequency accuracy: $\pm 9 \times 10^{-8}$	
5	Residual FM		Hz	2Hz - 4GHz (N=1): < 0.25	
				4GHz - 8GHz (N=1): < 0.25	
6	Frequency reading accuracy		kHz	1.5GHz (Span: 200kHz): $\pm 0.37$	
				1.5GHz (Span: 5MHz): $\pm 10.06$	
				1.5GHz (Span: 50MHz): $\pm 100.04$	
				1.5GHz (Span: 200MHz): $\pm 399.96$	
				1.5GHz (Span: 200MHz): $\pm 899.81$	
				1.5GHz (Span: 1GHz): $\pm 1650.0$	
				1.5GHz (Span: 50MHz): $\pm 0.43$	
				1.5GHz (Span: 5MHz): $\pm 10.12$	
				1.5GHz (Span: 50MHz): $\pm 100.10$	
				1.5GHz (Span: 200MHz): $\pm 400.02$	
				1.5GHz (Span: 200MHz): $\pm 899.87$	
				1.5GHz (Span: 1GHz): $\pm 1650.0$	

Table 7.2 (Continued)

No.	Test Item	Unit	Standard Requirement	Test result
7	Marker Counter	Hz	10MHz $\pm 0.100$	
			4GHz $\pm 0.100$	
			4GHz $\pm 0.100$	
8	Frequency bandwidth accuracy	Hz	Center frequency: 300.000004MHz Span: 10Hz $\pm 0.20\%$	
			Center frequency: 300.00004MHz Span: 100Hz $\pm 0.20\%$	
			Center frequency: 300.0004MHz Span: 1kHz $\pm 0.20\%$	
			Center frequency: 300.004MHz Span: 10kHz $\pm 0.20\%$	
			Center frequency: 300.04MHz Span: 100kHz $\pm 0.20\%$	
			Center frequency: 300.4MHz Span: 1MHz $\pm 0.20\%$	
			Center frequency: 304MHz Span: 10MHz $\pm 0.20\%$	
			Center frequency: 340MHz Span: 100MHz $\pm 0.20\%$	
			Center frequency: 700MHz Span: 1GHz $\pm 0.20\%$	
			Center frequency: 2000MHz Span: 4GHz $\pm 0.20\%$	
			Center frequency: 2000MHz Span: 4GHz $\pm 0.20\%$	

7 Technical indicators and testing methods

7.5 Performance characteristics test

No.	Test Item		Unit	Standard Requirement	Test result
9	RBW	Accuracy	/	20MHz: ±15.0%	
				10MHz: ±15.0%	
				5MHz: ±15.0%	
				3MHz: ±3.0%	
				2MHz: ±3.0%	
				1MHz: ±3.0%	
				500kHz: ±3.0%	
				300kHz: ±3.0%	
				200kHz: ±3.0%	
				100kHz: ±3.0%	
				50kHz: ±3.0%	
				30kHz: ±3.0%	
				20kHz: ±3.0%	
				10kHz: ±3.0%	
				5kHz: ±3.0%	
				3kHz: ±3.0%	
				2kHz: ±3.0%	
				1kHz: ±3.0%	
500Hz: ±3.0%					
300Hz: ±3.0%					

Table 7.2 (Continued)

No.	Test Item	Unit	Standard Requirement	Test result	
9	RBW	Accuracy	/	200Hz: ±3.0%	
			100Hz: ±3.0%		
			50Hz: ±3.0%		
			30Hz: ±3.0%		
			20Hz: ±3.0%		
			10Hz: ±3.0%		
			5Hz: ±3.0%		
			3Hz: ±3.0%		
			2Hz: ±3.0%		
		1Hz: ±3.0%			
		Selectivity	/	20MHz: 5.0:1	
			10MHz: 5.0:1		
			5MHz: 5.0:1		
			3MHz: 5.0:1		
			2MHz: 5.0:1		
			1MHz: 5.0:1		
			500kHz: 5.0:1		
			300kHz: 5.0:1		
			200kHz: 5.0:1		

7 Technical indicators and testing methods

7.5 Performance characteristics test

No.	Test Item	Unit	Standard Requirement	Test result
			100kHz: 5.0:1	
			50kHz: 5.0:1	
			30kHz: 5.0:1	
			20kHz: 5.0:1	
			10kHz: 5.0:1	
			5kHz: 5.0:1	
			3kHz: 5.0:1	
			2kHz: 5.0:1	
			1kHz: 5.0:1	
			500Hz: 5.0:1	
			300Hz: 5.0:1	
			200Hz: 5.0:1	
			100Hz: 5.0:1	
			50Hz: 5.0:1	
			30Hz: 5.0:1	

Table 7.2 (Continued)

No.	Test Item	Unit	Standard Requirement	Test result	
9	RBW	Selectivity	/	20Hz: 5.0:1	
				10Hz: 5.0:1	
				5Hz: 5.0:1	
				3Hz: 5.0:1	
				2Hz: 5.0:1	
				1Hz: 5.0:1	
10	Maximum analysis bandwidth	MHz			
11	Freq Resp. (Without preamplifier, or preamplifier OFF)		10MHz ~ 4GHz +0.40		
			10MHz ~ 4GHz -0.40		
			4GHz ~ 8GHz +0.70		
			4GHz ~ 8GHz -0.70		
	Freq Resp. (Preamplifier ON)	dB	10MHz ~ 4GHz +1.00		
			10MHz ~ 4GHz -1.00		
			4GHz ~ 8GHz +1.50		
			4GHz ~ 8GHz -1.50		
12	Overall absolute amplitude precision	dB	At 500MHz (calibration frequency) ±0.24		
13	RBW Conversion uncertainty	dB	20MHz: ±1.00		
			10MHz: ±0.30		
			5MHz: ±0.30		
13	RBW	dB	3MHz: ±0.30		

7 Technical indicators and testing methods

7.5 Performance characteristics test

No.	Test Item	Unit	Standard Requirement	Test result
	Conversion uncertainty		2MHz: $\pm 0.30$	
			1MHz: $\pm 0.10$	
			500kHz: $\pm 0.10$	
			300kHz: $\pm 0.10$	REF
			200kHz: $\pm 0.10$	
			100kHz: $\pm 0.10$	
			50kHz: $\pm 0.10$	
			30kHz: $\pm 0.10$	
			20kHz: $\pm 0.10$	
			10kHz: $\pm 0.10$	
			5kHz: $\pm 0.10$	

Table 7.2 (Continued)

No.	Test Item	Unit	Standard Requirement	Test result
13	RBW Conversion uncertainty	dB	3kHz: $\pm 0.10$	
			2kHz: $\pm 0.10$	
			1kHz: $\pm 0.10$	
			500Hz: $\pm 0.10$	
			300Hz: $\pm 0.10$	
			200Hz: $\pm 0.10$	
			100Hz: $\pm 0.10$	
			50Hz: $\pm 0.10$	
			30Hz: $\pm 0.10$	
			20Hz: $\pm 0.10$	
			10Hz: $\pm 0.10$	
			5Hz: $\pm 0.10$	
			3Hz: $\pm 0.10$	
			2Hz: $\pm 0.10$	
1Hz: $\pm 0.10$				
14	Reference level conversion error	dB	-10dBm: $\pm 0.20$	
			-20dBm: $\pm 0.20$	
			-30dBm: $\pm 0.20$	
			-40dBm: $\pm 0.20$	
			-50dBm: $\pm 0.20$	
			-60dBm: $\pm 0.20$	
			-70dBm: $\pm 0.20$	
15	Display scale fidelity	dB	Standard attenuator 10 dB $\pm 0.20$	
			Standard attenuator 10 dB $\pm 0.20$	
			Standard attenuator 10 dB $\pm 0.20$	

7 Technical indicators and testing methods

7.5 Performance characteristics test

			Standard attenuator 10 dB	$\pm 0.20$	
			Standard attenuator 10 dB	$\pm 0.20$	
			Standard attenuator 10 dB	$\pm 0.20$	
			Standard attenuator 10 dB	$\pm 0.20$	
16	1 dB gain compression	dBm	10MHz - 100MHz(30MHz)	$\geq 0$	
			10MHz - 100MHz(30MHz)	$\geq 0$	
			1GHz - 4GHz(2GHz)	$\geq 5.0$	
			4GHz - 8GHz(5GHz)	$\geq 5.0$	

Table 7.2 (Continued)

No.	Test Item	Unit	Standard Requirement	Test result
-----	-----------	------	----------------------	-------------

## 7.5 Performance characteristics test

17	Explicit average noise level	Preamplifier off	dBm/Hz	10MHz ~ 1GHz	< -151.0	
				1GHz ~ 2GHz	< -149.0	
				1GHz ~ 2GHz	< -147.0	
				1GHz ~ 2GHz	< -144.0	
				1GHz ~ 2GHz	< -147.0	
				1GHz ~ 2GHz	< -145.0	
	Preamplifier on	dBm/Hz	10MHz ~ 50MHz	< -156.0		
			10MHz ~ 1GHz	< -161.0		
			1GHz ~ 2GHz	< -161.0		
			1GHz ~ 2GHz	< -157.0		
18	Residual response		dBm	10MHz ~ 50MHz	< -90.0	
19	Second harmonic distortion	dBc	Input frequency range	Distortion		
			10MHz ~ 2GHz(1.6GHz)	< -60.0		
			2 GHz ~ 4GHz(3.5GHz)	< -60.0		
20	Third-order intermodulation distortion	dBc	Input frequency range	Distortion		
			2 GHz ~ 4GHz(3.5GHz)	> +120		
			2 GHz ~ 4GHz(3.5GHz)	> +170		
			2 GHz ~ 4GHz(3.5GHz)	> +160		
21	Phase noise (1GHz carrier)	dBc/Hz	Frequency offset +100Hz	< -95.0		
			Frequency offset +100Hz	< -95.0		
			Frequency offset +100Hz	< -112.0		
			Frequency offset +100Hz	< -112.0		
			Frequency offset +10kHz	< -122.0		
			Frequency offset +10kHz	< -122.0		
			Frequency offset +100kHz	< -122.0		
			Frequency offset +100kHz	< -122.0		
			Frequency offset +100Hz	< -135.0		
			Frequency offset +100Hz	< -135.0		
22	Image response	Third IF mirror response	dBc	1GHz (Input 850MHz)	≤-80.0	
				3GHz (Input 2.85GHz)	≤-80.0	
				3GHz (Input 2.85GHz)	≤-80.0	
	Second IF	dBc	1GHz (Input 1.85GHz)	≤-80.0		

7.5 Performance characteristics test

		mirror response		3GHz (Input 3.85GHz)	≤-80.0		
				3GHz (Input 3.85GHz)	≤-80.0		
		First mirror response	IF	dBc	3GHz (Input 3.85GHz)		≤-80.0
					3GHz (Input 13.45GHz)		≤-80.0
					3GHz (Input 3.85GHz)		≤-80.0

Table 7.2 (Continued)

No.	Test Item	Unit	Standard Requirement	Test result	
23	Interface	RF Input Interface	/	S4052: Type A/B, N type (female)	
		Communication Interface	/	USB interface: A-type, 3 on the front panel and 3 on the rear panel	
				Video interface: DP interface, DVI interface	
		LAN interface: Standard RJ45 type, 1000Base-T			
23	Interface	Communication Interface	/	IEEE-488 bus connector, 24-way plug (GP-IB code: SH1, AH1, T6, L4, SR1, RL1, PP0, DC1, or C0)	
		Auxiliary input/output interface	/	Earphone interface: standard 3.5 mm.	
		Time base Interface	/	10MHz reference input: 50 Ω impedance, BNC female connector	
				10 MHz reference output: 50 Ω impedance, BNC female connector	
		Trigger Interface	/	Trigger input 1(front panel): BNC female connector	
				Trigger input 2(rear panel): BNC female connector	
				Trigger output 1: BNC female connector;	
		Trigger output 2: BNC female connector;			
24	Safety	Insulation resistance	MΩ	The insulation resistance between the power input end of the equipment and the casing should not be less than 100 MΩ under standard atmospheric conditions for testing.	

## 7.5 Performance characteristics test

	Dielectric strength	/	AC 1500V, there should be no phenomena such as breakdown, flashover, and flicker.	
	Leakage current	mA	≤ 3.5	
Comprehensive judgment				

Table 7.3 Record sheet of S4052C/D/E/F/G/H signal/spectrum analyzer function performance test (Group A) (Type )

Instrument No.:

Test Personnel:

Test Condition:

Test Date:

No.	Test Item		Unit	Standard Requirement	Test result
1	Appearance		/	The appearance shall be clean and tidy, and the surface shall be free of rust, mildew, stains, peeling of plating coating and obvious scratches and burrs; plastic parts shall be free of bubble, crack or deformation; characters, symbols, marks and various signs shall be clean and firm. Structure members and control parts shall be integrate and free of any mechanical damage.	
2	Function	Functional normality	/	After power on, it can work normally, and there is no fault prompt during self inspection, with clear display. The positioning of keys, switches, knobs, and connectors should be correct, with clear connections, flexible rotation, and firm installation.	
		Main Functions	/	Spectrum analysis measurement function, supporting continuous sweep, FFT step sweep, gated sweep and other sweep methods	
	/		Power kit measurement function, supporting power measurement functions such as channel power, occupied bandwidth, adjacent channel power, power statistics, burst power, spurious emission, Spectrum Emission Mask, harmonic distortion, third-order intermodulation, etc		
	/		IQ analysis		
	/		Self testing and self calibration function, supporting internal state monitoring function		
3	Frequency range:		/	DC coupling: 2Hz - upper limit of model frequency range	
			/	AC coupling: 10MHz - upper limit of model frequency range	
4	Frequency reference		/	Frequency accuracy: $\pm 9 \times 10^{-8}$	

**7.5 Performance characteristics test**

No.	Test Item	Unit	Standard Requirement	Test result	
5	Residual FM	Hz	2Hz - 4GHz (N=1):	< 0.25	
			4GHz - 8GHz (N=1):	< 0.25	
			8GHz - 18GHz (N=2):	< 0.50	
			18GHz - 26.5GHz (N=4):	< 1.00	
			18GHz - 26.5GHz (N=4):	< 1.00	
			40GHz - 50GHz (N=8):	< 2.00	
6	Frequency reading accuracy	kHz	1.5GHz (Span: 200kHz):	$\pm 0.37$	
		kHz	1.5GHz (Span: 5MHz):	$\pm 10.06$	
		kHz	1.5GHz (Span: 50MHz):	$\pm 100.04$	
		kHz	1.5GHz (Span: 200MHz):	$\pm 399.96$	
		kHz	1.5GHz (Span: 200MHz):	$\pm 899.81$	
		kHz	1.5GHz (Span: 1GHz):	$\pm 1650.0$	
		kHz	1.5GHz (Span: 50MHz):	$\pm 0.43$	
		kHz	1.5GHz (Span: 5MHz):	$\pm 10.12$	
		kHz	1.5GHz (Span: 50MHz):	$\pm 100.10$	

Table 7.3 (Continued)

No.	Test Item	Unit	Standard Requirement	Test result	
6	Frequency reading accuracy	kHz	1.5GHz (Span: 200MHz): $\pm 400.02$		
		kHz	1.5GHz (Span: 200MHz): $\pm 899.87$		
		kHz	1.5GHz (Span: 1GHz): $\pm 1650.0$		
		kHz	1.5GHz (Span: 5MHz): $\pm 0.91$		
		kHz	15GHz (Span: 5MHz): $\pm 10.60$		
		kHz	1.5GHz (Span: 5MHz): $\pm 100.58$		
		kHz	1.5GHz (Span: 1GHz): $\pm 400.50$		
		kHz	1.5GHz (Span: 1GHz): $\pm 900.35$		
		kHz	15GHz (Span: 1GHz): $\pm 1650.0$		
		kHz	1.5GHz (Span: 5MHz): $\pm 1.31$		
		kHz	15GHz (Span: 5MHz): $\pm 11.00$		
		kHz	1.5GHz (Span: 5MHz): $\pm 100.98$		
		kHz	1.5GHz (Span: 1GHz): $\pm 400.90$		
		kHz	1.5GHz (Span: 1GHz): $\pm 900.75$		
		kHz	15GHz (Span: 1GHz): $\pm 1650.0$		
		kHz	1.5GHz (Span: 5MHz): $\pm 2.11$		
		kHz	15GHz (Span: 5MHz): $\pm 11.80$		
		kHz	1.5GHz (Span: 5MHz): $\pm 101.78$		
		kHz	1.5GHz (Span: 1GHz): $\pm 401.70$		
		kHz	1.5GHz (Span: 1GHz): $\pm 901.55$		
kHz	15GHz (Span: 1GHz): $\pm 1650.0$				
7	Marker Counter	Hz	10MHz	$\pm 0.100$	
			4GHz	$\pm 0.100$	
			4GHz	$\pm 0.100$	
			10MHz	$\pm 0.100$	
			26.5GHz	$\pm 0.100$	

7 Technical indicators and testing methods

7.5 Performance characteristics test

No.	Test Item	Unit	Standard Requirement	Test result
			10MHz ±0.100	
			10MHz ±0.100	
			10MHz ±0.100	
8	Frequency bandwidth accuracy	Hz	Center frequency: 300.000004MHz Span: 10Hz ± 0.20%	
			Center frequency: 300.00004MHz Span: 100Hz ± 0.20%	
			Center frequency: 300.0004MHz Span: 1kHz ± 0.20%	
			Center frequency: 300.004MHz Span: 10kHz ± 0.20%	
			Center frequency: 300.04MHz Span: 100kHz ± 0.20%	
			Center frequency: 2000MHz Span: 4GHz ± 0.20%	
			Center frequency: 304MHz Span: 10MHz ± 0.20%	
			Center frequency: 340MHz Span: 100MHz ± 0.20%	
			Center frequency: 700MHz Span: 1GHz ± 0.20%	

Table 7.3 (Continued)

No.	Test Item	Unit	Standard Requirement	Test result	
8	Frequency bandwidth accuracy	Hz	Center frequency: 700MHz Span: 1GHz $\pm$ 0.20%		
			Center frequency: 700MHz Span: 1GHz $\pm$ 0.20%		
			Center frequency: 340MHz Span: 100MHz $\pm$ 0.20%		
			Center frequency: 9000MHz Span: 18GHz $\pm$ 0.20%		
			Center frequency: 13250MHz Span: 26.5GHz $\pm$ 0.20%		
			Center frequency: 304MHz Span: 10MHz $\pm$ 0.20%		
			Center frequency: 304MHz Span: 10MHz $\pm$ 0.20%		
9	RBW	Accuracy	/	20MHz: $\pm$ 15.0%	
				10MHz: $\pm$ 15.0%	
				5MHz: $\pm$ 15.0%	
				3MHz: $\pm$ 3.0%	
				2MHz: $\pm$ 3.0%	
				1MHz: $\pm$ 3.0%	
				500kHz: $\pm$ 3.0%	
				300kHz: $\pm$ 3.0%	
				200kHz: $\pm$ 3.0%	
				100kHz: $\pm$ 3.0%	
				50kHz: $\pm$ 3.0%	
				30kHz: $\pm$ 3.0%	
				20kHz: $\pm$ 3.0%	
				10kHz: $\pm$ 3.0%	
				5kHz: $\pm$ 3.0%	
				3kHz: $\pm$ 3.0%	
				2kHz: $\pm$ 3.0%	
				1kHz: $\pm$ 3.0%	
				500Hz: $\pm$ 3.0%	
				300Hz: $\pm$ 3.0%	
200Hz: $\pm$ 3.0%					
100Hz: $\pm$ 3.0%					

7 Technical indicators and testing methods

7.5 Performance characteristics test

No.	Test Item	Unit	Standard Requirement	Test result
			50Hz: ±3.0%	
			30Hz: ±3.0%	
			20Hz: ±3.0%	
			10Hz: ±3.0%	

Table 7.3 (Continued)

No.	Test Item	Unit	Standard Requirement	Test result
-----	-----------	------	----------------------	-------------

## 7.5 Performance characteristics test

No.	Test Item		Unit	Standard Requirement		Test result
10	RBW	Accuracy	/	5Hz:	±3.0%	
				3Hz:	±3.0%	
				2Hz:	±3.0%	
				1Hz:	±3.0%	
		Selectivity	/	20MHz:	5.0:1	
				10MHz:	5.0:1	
				5MHz:	5.0:1	
				3MHz:	5.0:1	
				2MHz:	5.0:1	
				1MHz:	5.0:1	
				500kHz:	5.0:1	
				300kHz:	5.0:1	
				200kHz:	5.0:1	
				100kHz:	5.0:1	
				50kHz:	5.0:1	
				30kHz:	5.0:1	
				20kHz:	5.0:1	
				10kHz:	5.0:1	
				5kHz:	5.0:1	
				3kHz:	5.0:1	
				2kHz:	5.0:1	
				1kHz:	5.0:1	
				500Hz:	5.0:1	
				300Hz:	5.0:1	
200Hz:	5.0:1					
100Hz:	5.0:1					
50Hz:	5.0:1					
30Hz:	5.0:1					
20Hz:	5.0:1					
10Hz:	5.0:1					
5Hz:	5.0:1					

7 Technical indicators and testing methods

7.5 Performance characteristics test

No.	Test Item	Unit	Standard Requirement	Test result
			3Hz: 5.0:1	
			2Hz: 5.0:1	
			1Hz: 5.0:1	

Table 7.3 (Continued)

No.	Test Item	Unit	Standard Requirement	Test result
10	Maximum analysis bandwidth	MHz		

## 7.5 Performance characteristics test

No.	Test Item	Unit	Standard Requirement	Test result	
11	Freq Resp. (Without preamplifier, or preamplifier OFF)		10MHz ~ 4GHz	+0.40	
			10MHz ~ 4GHz	-0.40	
			4GHz ~ 8GHz	+0.70	
			4GHz ~ 8GHz	-0.70	
			8GHz ~ 18GHz	+2.00	
			8GHz ~ 18GHz	-2.00	
			18GHz ~ 26.5GHz	+2.50	
			18GHz ~ 26.5GHz	-2.50	
			26.5GHz ~ 40GHz	+2.80	
			26.5GHz ~ 40GHz	-2.80	
			40GHz ~ 50GHz	+3.20	
			40GHz ~ 50GHz	-3.00	
	Freq Resp. (Preamplifier ON)	dB	10MHz ~ 4GHz	+1.00	
			10MHz ~ 4GHz	-1.00	
			4GHz ~ 8GHz	+1.50	
			4GHz ~ 8GHz	-1.50	
			8GHz ~ 18GHz	+2.50	
			8GHz ~ 18GHz	-2.50	
			18GHz ~ 26.5GHz	+3.00	
			18GHz ~ 26.5GHz	-3.00	
			26.5GHz ~ 40GHz	+3.00	
			26.5GHz ~ 40GHz	-3.00	
			40GHz ~ 45GHz	+3.50	
			40GHz ~ 45GHz	-3.50	
45GHz ~ 50GHz	+3.50				
45GHz ~ 50GHz	-3.50				
12	Overall absolute amplitude precision	dB	At 500MHz (calibration frequency)	$\pm 0.24$	
13	RBW Conversion uncertainty	dB	20MHz:	$\pm 1.00$	
			10MHz:	$\pm 0.30$	
			5MHz:	$\pm 0.30$	

7.5 Performance characteristics test

Table 7.3 (Continued)

No.	Test Item	Unit	Standard Requirement	Test result
13	RBW Conversion uncertainty	dB	3MHz: $\pm 0.30$	
			2MHz: $\pm 0.30$	
			1MHz: $\pm 0.10$	
			500kHz: $\pm 0.10$	
			300kHz: $\pm 0.10$	REF

## 7.5 Performance characteristics test

			200kHz:	$\pm 0.10$	
			100kHz:	$\pm 0.10$	
			50kHz:	$\pm 0.10$	
			30kHz:	$\pm 0.10$	
			20kHz:	$\pm 0.10$	
			10kHz:	$\pm 0.10$	
			5kHz:	$\pm 0.10$	
			3kHz:	$\pm 0.10$	
			2kHz:	$\pm 0.10$	
			1kHz:	$\pm 0.10$	
			500Hz:	$\pm 0.10$	
			300Hz:	$\pm 0.10$	
			200Hz:	$\pm 0.10$	
			100Hz:	$\pm 0.10$	
			50Hz:	$\pm 0.10$	
			30Hz:	$\pm 0.10$	
			20Hz:	$\pm 0.10$	
			10Hz:	$\pm 0.10$	
			5Hz:	$\pm 0.10$	
			3Hz:	$\pm 0.10$	
			2Hz:	$\pm 0.10$	
			1Hz:	$\pm 0.10$	
14	Reference level conversion error	dB	-10dBm:	$\pm 0.20$	
			-20dBm:	$\pm 0.20$	
			-30dBm:	$\pm 0.20$	
			-40dBm:	$\pm 0.20$	
			-50dBm:	$\pm 0.20$	
			-60dBm:	$\pm 0.20$	
			-70dBm:	$\pm 0.20$	

7.5 Performance characteristics test

Table 7.3 (Continued)

No.	Test Item	Unit	Standard Requirement	Test result	
15	Display scale fidelity	dB	Standard attenuator 10 dB	± 0.20	
			Standard attenuator 10 dB	± 0.20	
			Standard attenuator 10 dB	± 0.20	
			Standard attenuator 10 dB	± 0.20	
			Standard attenuator 10 dB	± 0.20	
			Standard attenuator 10 dB	± 0.20	
			Standard attenuator 10 dB	± 0.20	
16	1 dB gain compression	dBm	10MHz - 100MHz(30MHz)	≥0	

## 7.5 Performance characteristics test

				10MHz - 100MHz(30MHz)	$\geq 0$	
				4GHz - 8GHz(5GHz)	$\geq 5.0$	
				4GHz - 8GHz(5GHz)	$\geq 5.0$	
				8GHz - 50GHz(15GHz)	$\geq 5.0$	
17	Explicit average noise level	Preamplifier off	dBm/Hz	10MHz ~ 1GHz	< -149.0	
				1GHz ~ 2GHz	< -147.0	
				2GHz ~ 3GHz	< -146.0	
				3GHz ~ 4GHz	< -141.0	
				4GHz ~ 6GHz	< -142.0	
				6GHz ~ 8GHz	< -139.0	
				8GHz ~ 18GHz	< -145.0	
				18GHz ~ 26.5GHz	< -141.0	
				26.5GHz ~ 40GHz	< -135.0	
				40GHz ~ 45GHz	< -134.0	
	45GHz ~ 50GHz	< -130.0				
		Preamplifier on	dBm/Hz	10MHz ~ 50MHz	< -156.0	
				50MHz ~ 4GHz	< -161.0	
				4GHz ~ 6GHz	< -161.0	
				6GHz ~ 8GHz	< -157.0	
				8GHz ~ 18GHz	< -157.0	
				18GHz ~ 26.5GHz	< -154.0	
				26.5GHz ~ 40GHz	< -151.0	
	40GHz ~ 50GHz			< -148.0		
18	Residual response		dBm	10MHz ~ 50MHz	< -90.0	
19	Second harmonic distortion		dBc	Input frequency range	Distortion	
				10MHz ~ 2GHz(1.6GHz)	< -60.0	
				2 GHz ~ 4GHz(3.5GHz)	< -60.0	
				4 GHz ~ 8GHz(8GHz)	< -70.0	
				8GHz ~ 25GHz(20GHz)	< -65.0	

## 7.5 Performance characteristics test

Table 7.3 (Continued)

No.	Test Item	Unit	Standard Requirement	Test result	
20	Third-order intermodulation distortion	dBc	Input frequency range	Distortion	
			10MHz ~ 200MHz(50MHz)	> +120	
			200MHz ~ 4GHz(1.5GHz)	> +170	
			4GHz ~ 8GHz(5GHz)	> +160	
			8GHz ~ 26.5GHz(10GHz)	> +160	
			26.5GHz ~ 50GHz(35GHz)	> +160	
21	Phase noise (1GHz carrier)	dBc/Hz	Frequency offset +100Hz	<-95.0	
			Frequency offset +100Hz	<-95.0	
			Frequency offset +1kHz	<-112.0	
			Frequency offset +1kHz	<-112.0	
			Frequency offset +10kHz	<-122.0	
			Frequency offset +10kHz	<-122.0	
			Frequency offset +100kHz	<-122.0	
			Frequency offset +100kHz	<-122.0	
			Frequency offset +1MHz	<-135.0	
			Frequency offset +1MHz	<-135.0	

## 7.5 Performance characteristics test

22	Image response	Third IF mirror response	dBc	1GHz (Input 850MHz)	$\leq -80.0$	
				3GHz (Input 2.85GHz)	$\leq -80.0$	
				5GHz (Input 5.15GHz)	$\leq -80.0$	
				15GHz (Input 14.85GHz)	$\leq -80.0$	
				25GHz (Input 24.85GHz)	$\leq -80.0$	
				35GHz (Input 35.15GHz)	$\leq -80.0$	
				45GHz (Input 44.85GHz)	$\leq -76.0$	
		Second IF mirror response	dBc	1GHz (Input 1.85GHz)	$\leq -80.0$	
				3GHz (Input 3.85GHz)	$\leq -80.0$	
				5GHz (Input 4.15GHz)	$\leq -80.0$	
				15GHz (Input 15.85GHz)	$\leq -80.0$	
				25GHz (Input 25.85GHz)	$\leq -70.0$	
				35GHz (Input 34.15GHz)	$\leq -70.0$	
				45GHz (Input 45.85GHz)	$\leq -70.0$	
		First IF mirror response	dBc	1GHz (Input 11.45GHz)	$\leq -80.0$	
				3GHz (Input 13.45GHz)	$\leq -80.0$	
				5GHz (Input 8.95GHz)	$\leq -80.0$	

## 7.5 Performance characteristics test

Table 7.3 (Continued)

No.	Test Item		Unit	Standard Requirement	Test result
23	Interface	RF Input Interface	/	S4052: C/D type, N type (female) E-type, 3.5mm (male) F/G/H type, 2.4mm (male)	
		Communication Interface	/	USB interface: A-type, 3 on the front panel and 3 on the rear panel	
				Video interface: DP interface, DVI interface	
				LAN interface: Standard RJ45 type, 1000Base-T	
		IEEE-488 bus connector, 24-way plug (GP-IB code: SH1, AH1, T6, L4, SR1, RL1, PP0, DC1, or C0)			
23	Interface	Auxiliary input/output interface	/	Earphone interface: standard 3.5 mm.	
		Time base Interface	/	10MHz reference input: 50 $\Omega$ impedance, BNC female connector	
				10 MHz reference output: 50 $\Omega$ impedance, BNC female connector	
		Trigger Interface	/	Trigger input 1(front panel): BNC female connector	
				Trigger input 2(rear panel): BNC female connector	
				Trigger output 1: BNC female connector;	
				Trigger output 2: BNC female connector;	
24	Safety	Insulation resistance	M $\Omega$	The insulation resistance between the power input end of the equipment and the casing should not be less than 100 M $\Omega$ under standard atmospheric conditions for testing.	

## 7.5 Performance characteristics test

	Dielectric strength	/	AC 1500V, there should be no phenomena such as breakdown, flashover, and flicker.	
	Leakage current	mA	≤ 3.5	
Comprehensive judgment				

Table 7.5 Record sheet of S4052 signal/spectrum analyzer function performance test (Group B) (Type )

Instrument No.:

Test Personnel:

Test Condition:

Test Date:

No.	Test Item	Unit	Standard Requirement	Test result
1	Swp time and range	/	Span=0Hz 1μs - 16000s	
		/	Span≥ 10Hz 1ms - 16000s	
2	Sweep time accuracy (span=0 Hz)		1ms ±0.01%	
			20ms ±0.01%	
			100ms ±0.01%	
			200ms ±0.01%	
			1s ±0.01%	
3	Trigger mode	/	Free trigger, power trigger, video trigger, External Trigger 1/2, Time Trigger	
			Trigger delay: 0 ~ +500 ms	
			Trigger delay resolution: 0.1μs	
4	Number range of sweep points	/	101 - 120001	
5	Input attenuator range	/	Input mechanical attenuator range: 0-70dB, in 2dB steps	
		/	Input electronic attenuator range: 0-30dB, in 1dB steps (option)	
6	Maximum safe input level	/	Average total power: +30dBm (1W)	
7	Display range	/	Scale type: logarithmic, linear	
		/	Scale type: 0.1 ~ 20 dB/grid, resolution: 0.01 dB	
		/	Scale unit: dBm, dBmV, dBμV, dBmA, dBμA, V, W, or A	
	Input voltage standing	/	50MHz - 4GHz < 1.40:1	

7 Technical indicators and testing methods

7.5 Performance characteristics test

No.	Test Item	Unit	Standard Requirement	Test result
8	wave ratio		4GHz - 8GHz < 1.50:1	
			8GHz - 18GHz < 1.80:1	
			18MHz - 45GHz < 1.70:1	
			45GHz - 50GHz < 2.00:1	
9	Display scale fidelity	dB	±0.20	
10	Detector Mode	/	Normal, positive peak, negative peak, sampling, video averaging, power averaging, and voltage averaging	
11	I/Q data storage depth	/	Analysis bandwidth ≤ 40MHz: 500M IQ sampling points IQ byte length: 32 bit I+32 bit Q	
			Analysis bandwidth > 40MHz: 1000M IQ sampling points IQ byte length: 16 bit I+16 bit Q	
12	VBW	/	1Hz - 20MHz (in steps of 1, 2, 3, and 5) (rated value)	
Comprehensive judgment				
Remarks: "√" indicates compliant; "×" indicates non-compliant; Typing "/" indicates that there is no content in this cell or this test item is not available on the machine.				

7.5.4 Auxiliary Test Table

Auxiliary table for functional performance test of S4052 spectrum analyzer (Type )

Instrument No.:

Test Personnel:

Test Condition:

Test Date:

Figure 7.6 Frequency reference accuracy

Output nominal frequency of the signal generator	Spectrum analyzer Marker Counter Measurement value	Frequency reference accuracy

Table 7.7 Residual FM

Band number	Testing frequency (GHz)	$\Delta f$	$\Delta L$	S	$\Delta A$	$R_{FM}$
0	1					
0	2					
1	5					
2	15					
3	25					
4	35					
5	45					

Table 7.8 Marker counting

Input signal nominal frequency	S4052 Marker Counter Frequency Value	Theoretical error range	Counting accuracy
10MHz			
4GHz			
8GHz			
26.5GHz			
45GHz			
50GHz			

Table 7.9 Span accuracy

7 Technical indicators and testing methods

7.5 Performance characteristics test

S4052 center frequency (MHz)	Signal generator frequency value # 1 (MHz)	Signal generator frequency value # 2 (MHz)	S4052 span	Marker Delta Frequency	Frequency bandwidth accuracy
300.000004	300	300.000008	10Hz		
300.00004	300	300.00008	100Hz		
300.0004	300	300.0008	1kHz		
300.004	300	300.008	10kHz		
300.04	300	300.08	100kHz		
300.4	300	300.8	1MHz		
304	300	308	10MHz		
340	300	38	100MHz		
700	300	1100	1GHz		
2000	400	3600	4GHz		
4000	800	7200	8GHz		
6600	1320	11880	13.2GHz		
9000	1800	16200	18GHz		
13250	2650	23850	26.5GHz		
20000	4000	36000	40GHz		
25000	5000	45000	50GHz		

Table 7.10 Sweep time accuracy

Sweep time settings	Modulation frequency	Time difference $\Delta T$	Sweep time accuracy
1ms	10kHz		
20ms	500Hz		
100ms	100Hz		
200ms	50Hz		
1s	10Hz		

Table 7.11 Resolution bandwidth

RBW	3 dB bandwidth measurement value	RBW Accuracy	3 dB bandwidth measurement value	Resolution bandwidth selectivity
20MHz				
10MHz				
8MHz				
6MHz				
5MHz				
4MHz				

## 7.5 Performance characteristics test

3MHz				
2MHz				
1MHz				
500kHz				
300kHz				
200kHz				
100kHz				
50kHz				
30kHz				
20kHz				
10kHz				
5kHz				
3kHz				
2kHz				
1kHz				
500Hz				
300Hz				
200Hz				
100Hz				
50Hz				
30Hz				
20Hz				
10Hz				
5Hz				
3Hz				
2Hz				
1Hz				

Table 7.12 Maximum analysis bandwidth

Setting value of maximum analysis bandwidth	Left limit value $f_L$	Right limit value $f_R$	Measured value of maximum analysis bandwidth
10MHz			
40MHz			
200MHz			

7 Technical indicators and testing methods

7.5 Performance characteristics test

400MHz			
600MHz			

Table 7.13 Frequency response

Amplitude error (0-band, 10MHz - 4GHz)

Frequency (MHz)	S4052 Marker reading $L_2$ (dBm)	Power meter reading $L_1$ (dBm)	Amplitude error
10			
50			
100			
300			
500			
700			
900			
1100			
1300			
1500			
1700			
1900			
2100			
2300			
2500			
2700			
2900			
3100			
3300			
3500			
3700			
3900			

Amplitude error (2-band, 10MHz - 4GHz)

Frequency (GHz)	S4052 Marker reading $L_2$ (dBm)	Power meter reading $L_1$ (dBm)	Amplitude error
4.00			
4.50			
5.00			
5.50			
6.00			

**7.5 Performance characteristics test**

6.50			
7.00			
7.50			
8.00			

Amplitude error (3-band, 10MHz - 4GHz)

Frequency (GHz)	S4052 Marker reading $L_2$ (dBm)	Power meter reading $L_1$ (dBm)	Amplitude error
8.50			
10.00			
10.50			
11.00			
11.50			
12.00			
12.50			
13.00			
13.50			
14.00			
14.50			
15.00			
15.50			
16.00			
16.50			
17.00			
17.50			
18.00			

Amplitude error (4-band, 10MHz - 4GHz)

Frequency (GHz)	S4052 Marker reading $L_2$ (dBm)	Power meter reading $L_1$ (dBm)	Amplitude error
18.50			
19.00			
19.50			
20.00			
20.50			
21.00			
21.50			

7 Technical indicators and testing methods

7.5 Performance characteristics test

22.00			
22.50			
23.00			
23.50			
24.00			
24.50			
25.00			
25.50			
26.00			
26.50			

Amplitude error (5-band, 10MHz - 4GHz)

Frequency (GHz)	S4052 Marker reading $L_2$ (dBm)	Power meter reading $L_1$ (dBm)	Amplitude error
27.00			
27.50			
28.00			
28.50			
29.00			
29.50			
30.00			
30.50			
31.00			
31.50			
32.00			
32.50			
33.00			
33.50			
34.00			
34.50			
35.00			
35.50			
36.00			
36.50			
37.00			
37.50			

## 7.5 Performance characteristics test

Frequency (GHz)	S4052 Marker reading $L_2$ (dBm)	Power meter reading $L_1$ (dBm)	Amplitude error
38.00			
38.50			
39.00			
39.50			

## Amplitude error (6-band, 10MHz - 4GHz)

Frequency (GHz)	S4052 Marker reading $L_2$ (dBm)	Power meter reading $L_1$ (dBm)	Amplitude error
40.50			
41.00			
41.50			
42.00			
42.50			
43.00			
43.50			
44.00			
44.50			
45.00			
45.50			
46.00			
46.50			
47.00			
47.50			
48.00			
48.50			
49.00			
49.50			
50.00			

## Frequency response statistical results (without preamplifier or preamplifier OFF)

Frequency range:	Maximum amplitude error value $\Delta A_{max}$	Minimum amplitude error value $\Delta A_{min}$	Freq Resp.
10MHz~4GHz			
4GHz~8GHz			
8GHz~18GHz			
18GHz~26.5GHz			

7 Technical indicators and testing methods

7.5 Performance characteristics test

26.5GHz~45GHz			
45GHz~50GHz			

Frequency response statistical results (preamplifier ON)

Frequency range:	Maximum amplitude error value $\Delta A_{max}$	Minimum amplitude error value $\Delta A_{min}$	Freq Resp.
10MHz~4GHz			
4GHz~8GHz			
8GHz~18GHz			
18GHz~26.5GHz			
26.5GHz~45GHz			
45GHz~50GHz			

Table 7.14 Absolute amplitude accuracy

500MHz absolute amplitude accuracy

Frequency (MHz)	S4052 Marker reading L2 (dBm)	Power meter reading L1 (dBm)	Absolute amplitude accuracy
500			

Table 7.15 Conversion error of resolution bandwidth

RBW	Measurement value
20MHz	
10MHz	
5MHz	
3MHz	
2MHz	
1MHz	
500kHz	
300kHz	0 (ref)
200kHz	
100kHz	
50kHz	
30kHz	
20kHz	
10kHz	
5kHz	
3kHz	
2kHz	
1kHz	

## 7.5 Performance characteristics test

500Hz	
300Hz	
200Hz	
100Hz	
50Hz	
30Hz	
20Hz	
10Hz	
5Hz	
3Hz	
2Hz	
1Hz	

Table 7.16 Reference level conversion error

Ref Level	Standard attenuator		Delta marker reading $\Delta L$ (dB)	Conversion error (dB)
	Setting value (dB)	Calibration value $A_{ATT}$ (dB)		
0dBm	0	0dB	0 (ref)	0dB (ref)
-10dBm	10			
-20dBm	20			
-30dBm	30			
-40dBm	40			
-50dBm	50			
-60dBm	60			
-70dBm	70			

Table 7.17 Scale fidelity

Standard attenuator		Delta marker reading $\Delta L$ (dB)	Scale error (dB)
Setting value (dB)	Calibration value $A_{ATT}$ (dB)		
0	0dB	0 (ref)	0dB (ref)
10			
20			
30			
40			
50			
60			

## 7.5 Performance characteristics test

70			
----	--	--	--

Table 7.18 Residual response

Frequency range:	Frequency value	Response value
200kHz~8GHz		

## 7.5.5 Recommended instrument for performance characteristics test

Table 7.19 Recommended instrument for performance characteristics test

No.	Instrument	Main technical indicators	Recommended model
1	Composite Signal Generator	Frequency range: 250kHz~50GHz Power output: -100dBm to +15dBm Frequency accuracy:± 0.02% Power level can be calibrated and stored With internal and external AM mode	E8257D or E8257D 或 1465H L
2	Power meter host	Power range: -70dBm ~ +20dBm Calibration source amplitude: 0dBm	2438CB N1914A
3	Power probe	Frequency range: 9kHz~50GHz Power range: -30dBm ~ +20dBm	71710A (9kHz -12GHz; -30dBm to +20dBm), 71710L(50MHz - 67GHz; -30dBm to +20dBm) E9301B (10MHz - 6GHz; -30dBm to +44dBm)
4	Vector network analyzer	Frequency range: 50MHz~50GHz	3672D
5	Spectrum analyzer	Frequency range: 3Hz~40GHz	4051F
6	Power splitter	Frequency range: 50kHz~67GHz Insertion loss: 6dB Equivalent output VSWR:<1.22	11667C
7	Calibrate programmable step attenuator	10dB step, a total of 90dB, with calibration certificate	84906L
8	Attenuator switch controller	Voltage output: 5,15,&24V, GPIB,USB,LAN (LXIClass C)	11713C
9	RF directional coupler	Frequency range: 300kHz~4GHz	Homemade

## 7.5 Performance characteristics test

		Directivity: 35dB VSWR:<1.45	
10	Directional coupler/2.4mm bridge	Frequency range: 2GHz ~ 40GHz Coupling factor: 16 dB Maximum coupling deviation: ± 1dB Directivity: 35dB Flatness: 0.75dB Insertion loss:<1.3dB	70603/80622F
11	Low-pass filter	Ending frequency: 1.6GHz Insertion loss:<1.3dB Out-of-band inhibition: >65dB	Homemade
12	Low-pass filter	Ending frequency: 1.6GHz Insertion loss:<1.3dB Out-of-band inhibition: >65dB	Homemade
13	Low-pass filter	Ending frequency: 1.6GHz Insertion loss:<1.3dB Out-of-band inhibition: >65dB	Homemade
14	Low-pass filter	Ending frequency: 1.6GHz Insertion loss:<1.3dB Out-of-band inhibition: >65dB	Homemade
15	Low-pass filter	Ending frequency: 1.6GHz Insertion loss:<1.3dB Out-of-band inhibition: >65dB	Homemade
16	Isolator	Conduction frequency 3GHz ~ 6.8GHz Reverse isolation degree: 20dB	CTP-3060
17	Load	Impedance: 50Ω	SMA-50JR
18	Adapter	2.4 (f) to 3.5 (f)	Homemade
19	Isolator	Conduction frequency 3GHz ~ 6.8GHz Reverse isolation degree: 20dB	XTP-1218A
20	Low-loss cables	2.4mm cable (m-m) (2 cables required)	Homemade
21	Cable	BNC cable (two required)	Homemade
22	Vernier caliper	0 ~ 1000mm	41-A-54
23	platform scale	TGT-100	00000051
24	Computer	WinXP or Win7 platform	
25	Leakage current puncture tester	Leakage current 0.5 mA ~ 20mA, voltage 242V, 3kV and 5kV	CJ2673
26	Digital megohmmeter	FLUKE1508	FLUKE1508
27	Variable-frequency power source	Frequency 47Hz ~ 400Hz, voltage 0 ~ 3000V	AFC-1kW
28	Temperature & humidity chamber	Temperature -70°C ~ to +150°C, humidity (25-98)%RH	ESL-10P

## 7 Technical indicators and testing methods

### 7.5 Performance characteristics test

29	Temperature & humidity chamber	Temperature -70 °C~ to +80 °C , humidity ( 50-98)%RH	Y751C
30	Impact testbed	Maximum load 100kg, acceleration (50-400)m/s <sup>2</sup>	P-100
31	Electrodynamic vibration generator	Vertical generator: max. displacement 25mm, max. frequency 3000Hz Min. frequency 5Hz, max. load 200kg Horizontal table: maximum displacement 25mm, frequency range 5Hz -1000Hz Maximum load: 100kg	D-600-3

## Annex

Annex A Terminology Description .....	2 0 1
Annex B Zoom Table of SCPI Commands .....	2 1 0
Annex C Zoom Table of Failure Information.....	2 1 0

### Annex A Terminology

#### LO

The short for the local oscillator. In the signal/spectrum analyzer, the local oscillator frequency is mixed with the received signal to generate the IF signal of instrument.

#### Local oscillator feed-through

A significant defect of the superheterodyne signal/spectrum analyzer is the LO feedthrough. If the LO frequency is the same (or very close) to the intermediate frequency, the LO signal will appear in the measurement through the IF filter, and the vibration frequency corresponds to the 0Hz (DC) input frequency and can be used as a 0Hz frequency marker. Therefore, the LO feedthrough is also called DC response. For a finite bandwidth IF filter, the LO feedthrough extends from 0 Hz to approximately  $BW_{RES}/2$ , which has similar shape of the filter curve of the IF filter.

#### Waveform factor

The ratio of the 60dB (or 40dB) bandwidth to the 3dB bandwidth of the filter, also known as the rectangle coefficient, represents the steepness and selectivity of the filter. Waveform factor affects the resolution of unequal amplitude signals of the signal/spectrum analyzer.

#### Units of measurement

The common measurement units of signal/spectrum analyzer are shown in Table 1:

Table 1 Unit of measurement

Measurement parameters	Name of Unit	Unit Abbreviation
Frequency	Hertz	Hz
Power level	Decibel relative to milliwatt	dBm
Power ratio	Decibel	dB
Voltage	Volt	V
Time	S	s
Impedance (resistance)	Ohm	$\Omega$

#### Menus

The signal/spectrum analyzer function information prompted on the right side of the screen display area is activated by pressing the corresponding hard key or soft key on the front panel.

## Annex A Terminology

### Ref Level

Description: The vertical scale position that has been calibrated on the signal/spectrum analyzer screen is used as the reference of amplitude measurement. The reference level usually refers to the top scale line.

### Measuring range

The power ratio (dB) of the maximum signal (usually the maximum safe input level) and the minimum signal (displaying the average noise level) that can be measured at the input of the signal/spectrum analyzer within a given accuracy range, which is usually much larger than the dynamic range that can be achieved in a single measurement.

### Difference marker

One way of marking the marker, one of which is a fixed reference marker, and the other is an active marker that can be placed anywhere on the display trace, and the displayed data is the relative amplitude and frequency difference (or time difference) between the active marker and fixed reference marker.

### Impact bandwidth

According to the principle of voltage equivalence, the area enclosed by the voltage response curve of the actual signal/spectrum analyzer filter is equivalent to the voltage response curve of an ideal rectangular filter of the same area, and the height of the two curves is equal. The width of the rectangular filter is called the equivalent impulse bandwidth. It is different from signal bandwidth and noise bandwidth. In the signal/spectrum analyzer, the impact bandwidth is about 1.5 times of the 3dB bandwidth.

### Bandwidth selectivity

Bandwidth selectivity, also known as the rectangular coefficient, is an indicator for evaluating the ability of a signal/spectrum analyzer to resolve unequal amplitude signals, and usually defines the ratio of the 60dB bandwidth to the 3dB bandwidth of the filter. The bandwidth selectivity indicates the steepness of the filter edge.

### Dynamic range

The maximum power ratio between two or more signals present at the input of the signal/spectrum analyzer at the specified accuracy, expressed in dB, characterizes the ability to measure the difference in amplitude of two or more signals simultaneously. The dynamic range has multiple signal dynamic range, single signal dynamic range, instantaneous dynamic range, and safe dynamic range, which has different from the concept of displaying range and measurement range. Factors affecting the dynamic range include display average noise level, internal distortion, noise sidebands, input attenuators, logarithmic amplifiers, detectors and AD converters.

The optimal second- and third-order distortion-free measurement dynamic range can be calculated based on the following formula.

$$MDR_2 = \frac{1}{2} \times (SHI - DANL)$$

$$MDR_3 = \frac{2}{3} \times (TOI - DANL)$$

Where:

MDR2—the optimal second-order distortion-free measurement dynamic range

SHI—second-harmonic intercept point

DANL—Explicit average noise level

MDR3—the optimal third-order distortion-free measurement dynamic range

TOI —third-order distortion interception point

### Logarithmic scale display

The vertical scale on the display is displayed logarithmically. In the logarithmic mode, dBm, dBmV, dBμV, W and V can be used as the amplitude unit.

## Spurious response

The unexpected spurious signals on the signal/spectrum analyzer display. Spurious response consists of spurious response and residual response, the former refers to the abnormal response occurred in the signal/spectrum analyzer display along with the input signal, consisting of harmonic response, intermodulation response, mirror frequency response, multiple response and out-of-band response; the spurious response can also be divided into the harmonic response and non-harmonic response, and the later refers to the intermodulation response and residual response. The sub-items are described below:

a) Harmonic distortion

When the input signal amplitude increases to a level to let the mixer works in the non-linear status, the mixer will generate harmonic components of such input signal, and such components are called harmonic distortion.

b) Mirror frequency and multiple responses

During frequency mixing, two input signals can generate the same IF signal with that of the LO signal with the same frequency, with one signal frequency one IF lower than the LO and another signal frequency one IF higher than the LO. In this case, one of the signal is called the mirror frequency of the other. Each frequency of the LO has a mirror frequency of corresponding input signal, with the difference of two IFs between the signal and the mirror frequency.

Multiple responses refer to two or multiple responses caused by the input signal with signal frequency on the display, that is, to respond to two or multiple LO frequencies, the interval between the LO frequencies of such multiple responses is two times of the IF. Multiple responses occur only when the mixing mode overlaps and LO sweeps a sufficient range to make the input signal mixed in more than one mode. Different signal/spectrum analyzers have different principle structures, and the frequency causing mirror and multiple responses varies, too.

c) Residual response

Residual response indicates the discrete response observed on the display when the signal/spectrum analyzer does not receive any input signal.

## FFT

Abbreviation for Fast Fourier Transform. It performs a specific mathematical analysis of the time domain signal and gives the results of the frequency domain analysis.

## Resolution

Resolution is used to represent the capability of the signal/spectrum analyzer to clearly separate two input signals. It is subject to the influence of some factors such as IF filter bandwidth, rectangle coefficient, local-oscillator residual frequency modulation, phase noise and sweep time. Most signal/spectrum analyzers can be used to test different resolution bandwidths by using the LC filter, crystal filter, SAW, digital filter, etc.

## Amplitude accuracy

A parameter associated with the amplitude measurement result that characterizes the dispersion of the amplitude measurement value. Factors affecting amplitude measurement accuracy include frequency response, display fidelity, input attenuator conversion error, IF gain, scale factor and resolution bandwidth.

## Negative peak detection

A display detection method for signal energy, each displayed point corresponds to a plurality of detected sample data points of a video signal in a portion of a frequency span or time interval represented by the point, and the method for extracting the minimum of the data points is called negative peak detection.

## Trace

A trace consists of a series of data points containing frequency (time) and amplitude information, which are usually treated as a set.

## Annex A Terminology

Traces 1, 2, and 3 are the names of the traces often used by signal/spectrum analyzers.

### Intermodulation

If two or more signals are simultaneously loaded at the input of an active device (such as an amplifier or a mixer), multiple sum frequency and/or difference frequency component of each signal itself produces intermodulation products due to the nonlinearity of the active device and the harmonics of the generated signal. For signal/spectrum analyzers, these intermodulation products are interference signals, the lower the level, the better the result. The relationship between the level of the intermodulation product and level of the input signal is: if the amplitude of the two sinusoidal input signals varies by  $\Delta$  dB, the corresponding intermodulation product level will vary by  $n \cdot \Delta$  dB, where  $n$  is the order of the intermodulation product, and represents the sum of the sub-items of the contained frequencies, such as the frequency  $2 \cdot f_1 + 1 \cdot f_2$ , and the order is  $2+1=3$ . The intersection point when the amplitude of the signal and intermodulation product is equal is usually called the intercept point. In fact, this point does not exist because the output of the active device is compressed when the input signal is amplified to a certain extent. The intercept point can be defined by the input level or output level, so the nominal intercept point has an input and output intercept point, which refers to the input intercept point unless otherwise specified. The intercept point is usually expressed in dBm. The larger the intercept point, the better the linearity of the signal/spectrum analyzer, which is a prerequisite for obtaining a large dynamic range. In most cases, among the intermodulation products, the second-order products and the third-order products have the greatest impact on the measurement. The second-order intercept point is often defined as IP2 or SOI (Second Order Intercept), and the third-order intercept point is IP3 or TOI (Third Order Intercept). The calibration of interception point must specify the value of the input attenuator at the front end of the signal/spectrum analyzer (usually 0 dB) as the intercept point will also increase as the attenuation of the attenuator increases.

The linearity of active devices varies with the increase of current and power. In normal case, the current supplied by the amplifier is proportional to the LO power of the mixer, which will significantly improve the linearity, so the low power consumption of the signal/spectrum analyzer is often equivalent to poor linearity. However, it should be noted that this noise requirement is also contradictory. The input attenuator of the signal/spectrum analyzer can control the intermodulation products, and has a higher IP3 value under a higher noise factor, so IP3 and noise factor should be analyzed and compared in the same mode of operation. IP<sub>3</sub> is an important index to measure the linearity of the signal/spectrum analyzer, which reflects the Intermodulation of the signal/spectrum analyzer when subjected to strong signal interference.

### Active Function Zone

The screen area of activation function and its state display of signal/spectrum analyzer. The activation function is the function that is activated by the last time the signal/spectrum analyzer is pressed or by the last programmed command.

### Detector Mode

The mode in which the analog information is digitized and saved into the memory is mainly used as a display detection method for the signal energy in the signal/spectrum analyzer. This includes "positive peak", "negative peak", "normal", "sampling", and "average".

### Scale factor

The unit of value represented by each pattern on the vertical axis of the display.

### Zero span

The sweep LO of the signal/spectrum analyzer is fixed at a certain frequency, that is, the LO does not sweep (the span is equal to zero). At zero span, the signal/spectrum analyzer becomes a fixed-tuned receiver and the bandwidth of it is the resolution bandwidth.

### Drift

The local oscillator frequency is subject to the change in the sweep voltage, resulting in a slow change in signal position on the display.

If drift occurs, it may need to be re-adjusted without compromising the frequency resolution.

### Freq Resp.

The frequency response indicates the change of the amplitude with the frequency within the specified frequency span, that is, the dependency between the amplitude and the frequency. The frequency response is divided into an absolute frequency response and a relative frequency response. The absolute frequency response is the amplitude deviation of the remaining frequency points when the signal amplitude of a certain frequency point is used as a reference within a given frequency range. The relative frequency response, also known as the frequency response flatness, represents the difference or plus or minus one-half of the difference between the maximum amplitude and the minimum amplitude within one frequency range or the entire frequency range.

### Marker

A visible indicating marker that can be placed anywhere on the trace of the screen, showing the absolute value of the frequency and amplitude of the trace on the marker point with the number. Active markers are the markers located on the trace that can be moved directly by front panel control keys or programmed control commands.

### Span

The difference between the start frequency and the stop frequency on the signal/spectrum analyzer. The setting of the span determines the scale of the horizontal axis of the signal/spectrum analyzer display

### Frequency range:

The range between the min. frequency and max. frequency that can be measured by the signal/spectrum analyzer under the specified performance conditions. The frequency span and relevant frequency band division shall be specified in the product specifications.

### Frequency accuracy

The measured frequency shows how close the value is to the true value. It consists of absolute accuracy and relative accuracy. The former is the actual size of the readout frequency error, and the latter is the ratio of the readout frequency error to the ideal frequency value.

### Frequency stability

Refers to the extent to which the signal frequency remains constant in the short or long term. Short-term frequency stability is characterized by residual frequency or phase noise. Long-term frequency stability is characterized by the aging rate.

### Signal/spectrum analyzer

An instrument that can effectively display the individual spectral components (sine waves) that make up a time-domain signal in the frequency domain. Whether to retain phase information depends on the type and design principle of the analyzer.

### Flatness

Corresponding to the variation of the display amplitude of the measurement frequency range of the signal/spectrum analyzer, indicating the corresponding relationship between the displayed signal amplitude variation and the frequency.

### Sample detection method

A display detection method for signal energy, the value displayed at each point is the instantaneous value of the video signal at a certain time interval or time interval represented by the point.

## Annex A Terminology

### Swp Time

The time that the LO passes selected frequency interval. The sweep time directly affects the time it takes to complete a test, but does not include the dead time between completing one sweep and starting the next sweep. At zero span, the horizontal axis is only calibrated for time. At non-zero span, the horizontal axis calibrates both frequency and time. The sweep time typically varies with span, resolution bandwidth and video bandwidth.

### RF Attenuator

The step attenuator between the input connector of the signal/spectrum analyzer and the first mixer. The RF attenuator is used to adjust the signal level input to the first mixer.

### Residual FM

The inherent short-term frequency instability of the local oscillator signal without any modulation input. It generally refers to the peak or peak-to-peak value of the frequency jitter over a specified time interval for a specified test bandwidth. The residual frequency modulation will cause the spectral line to shake, reduce the actual resolution, and affect the frequency readout accuracy of the signal/spectrum analyzer.

### Video

The signal output from the detector in the signal/spectrum analyzer. The frequency range extends from 0Hz to a frequency far beyond the widest resolution bandwidth provided by the signal/spectrum analyzer. The setting of the video filter determines the final bandwidth of the video path.

### VBW

The bandwidth of the adjustable low-pass filter in the video circuit of the signal/spectrum analyzer. The video filter behind the detector is a low-pass filter determining the bandwidth of the video amplifier. With the noise smoothing function, it is used to average or smooth the trace; it can easily detect weak signals in noise. Change of the video bandwidth does not affect the frequency resolution of the signal/spectrum analyzer. However, if the selected video bandwidth is too narrow, the sweep time would be increased.

### Video amplifier

The DC coupled amplifier behind the detector in the signal/spectrum analyzer.

### Video filtering and video averaging

The signal/spectrum analyzer displays the measured signal plus its own internal noise. In order to reduce the influence of noise on measuring the amplitude of the small signal, the signal to be displayed is subject to video filtering or video averaging.

Video filtering is low-pass filtering after the envelope detector. If the video bandwidth is equal to or less than the resolution bandwidth, the video circuit cannot fully respond to the rapid fluctuation of the detector output, and then the display trace is smoothed. The degree of this average or smoothness is linked with the ratio of video bandwidth to resolution bandwidth.

Video averaging is averaged point by point during multiple sweeps. At each point, the newly measured data is averaged together with the previously measured data, and the display value is gradually become the average of several measurements. It is used only on digitally displayed analyzers, the calculation of the average is determined by the sweep times selected by the user. The averaging algorithm uses the weighting factor  $(1/n)$ ,  $n$  is the current number of sweeps) for the given point's amplitude of current sweep, and the other weighting factor  $[(n-1)/n]$  for the previously stored average, and then the two values are combined into the current average. After the specified number of sweeps is completed, the weighting coefficients remain unchanged and the display becomes dynamic average.

In most measurement situations, the video filtering and video average are essentially the same. But there is a difference between the two. Video filtering is a real-time average, and when measuring a signal that drifts over time, the difference between the two methods becomes significant, which may result in completely different results. When using video filtering, each sweep may give different average

values; Video averaging is achieved by using multiple sweep to achieve sufficient averaging, thus obtaining a result that is very close to the true average.

### Input amplitude range

The power ratio (dB) of the maximum signal (usually the maximum safe input level) and minimum signal (display average noise level) that can be measured at the input of the signal/spectrum analyzer within a given accuracy range, which is always much larger than the dynamic range that can be achieved in a single measurement.

### Input impedance

The terminal impedance of the signal/spectrum analyzer to signal source. The impedance of RF and microwave analyzer is typically 50Ω. The normal impedance of some systems (for example, the cable TV) is 75Ω. The mismatch degree between the rated impedance and actual one is expressed with the voltage standing wave ratio (VSWR).

### Refresh mode

Used to clear screen traces and sweep again after encountering triggering conditions. When the triggering conditions are met, new input signal data will be displayed.

### Display range

The difference between the maximum signal and the minimum signal can be observed simultaneously on the display. For the signal/spectrum analyzer with 10 amplitude scale intervals, the display range is the scale factor \* 10.

### Explicit average noise level

In case of minimum resolution bandwidth and minimum input attenuation, the video bandwidth is reduced to minimize the peak-to-peak fluctuation of the noise, and the level observed on the signal/spectrum analyzer display is the display average noise level, expressed in dBm. The displayed average noise level of the signal/spectrum analyzer can be equivalently called to the sensitivity of the signal/spectrum analyzer.

### Linear display

The vertical scale on the display is proportional to the input signal voltage. The bottom line of the screen represents 0V, and the top line represents the reference level (depending on a non-zero value of the specific signal/spectrum analyzer). For most signal/spectrum analyzers, the scale factor is equal to the reference level value divided by the number of cells. In the linear display mode, the amplitude of the signal/spectrum analyzer can be expressed in dBm, dBmV, dBuV, W and V.

### Relative amplitude precision

Amplitude measurement error. The amplitude of one of the signals is compared to the amplitude of the other, regardless of the absolute amplitude of either. Factors affecting relative amplitude accuracy include frequency response, display fidelity, change in input attenuation, IF gain, scale factor and resolution bandwidth.

### Preselector

The band pass filter with adjustable center frequency before the input mixer of signal/spectrum analyzer. It is used to eliminate the multiple response and mirror response of the superheterodyne signal/spectrum analyzer, and improve the dynamic range of the signal/spectrum analyzer. The preselector is generally used in frequency bands above 4GHz.

## Annex A Terminology

### Sensitivity

The ability of the signal/spectrum analyzer to measure the minimum level signal. Sensitivity is further divided into input signal level sensitivity and equivalent input noise sensitivity. The output produced by the former is approximately equal to twice of input signal level of average noise value, and the latter is the average level of internally generated noise converted to the input. The best sensitivity is obtained with the narrowest resolution bandwidth, minimum input attenuation, and adequate video filtering. Factors affecting sensitivity include input attenuators, preamplifier, insertion loss of front-end devices, bandwidth and noise sidebands of IF filters. Although video filters do not improve sensitivity, it can improve discriminability and repeatability of measurements at low signal-to-noise ratios. The best sensitivity may conflict with other measurement needs. For example, a smaller resolution bandwidth increases the sweep time; 0 dB input attenuation increases the input standing wave ratio (VSWR), which reduces the measurement accuracy; and the increase of preamplifiers will affect the dynamic range of the signal/spectrum analyzer. The relationship between sensitivity and resolution bandwidth is as follows:

$$PdBm = -174dBm + FdB + 10\text{Log}B$$

Where:

PdBm - Sensitivity of the signal/spectrum analyzer

FdB - Noise figure of the signal/spectrum analyzer

B - 3dB bandwidth of the signal/spectrum analyzer (in Hz)

### Noise marker

A marker that uses its value to represent the noise level within the 1 Hz equivalent noise bandwidth. If the noise marker is selected, the sample detection mode is initiated, average several trace points around the marker (number of points depends on the analyzer), which normalizes the power within the 1 Hz equivalent noise bandwidth.

### Phase noise (noise sideband)

The oscillator in the signal/spectrum analyzer is used to convert the input signals of different frequencies to the intermediate frequency. The phase noise represents the relative value of the noise power and carrier power in the 1 Hz equivalent noise bandwidth at a certain frequency offset of the carrier, which is commonly expressed in dBc/Hz. It is a measure of the oscillator's short-term frequency stability, which is caused by phase or frequency variations, and is expressed as a bell-like noise characteristic in the oscillator signal. It affects the measurement ability of the whole machine to the phase noise of the measured signal, and also affects the sensitivity and dynamic range of the whole machine.

### Harmonic mixing

The local oscillator harmonics "generated" in the mixer are used to participate in the mixing to expand the tuning measurement range of the signal/spectrum analyzer.

### Gain compression

If the input signal level is increased, the mixer circuit, amplifier and other unit circuits of the signal/spectrum analyzer may work close to the saturation point. At this time, the output signal component no longer changes linearly with the input signal, and the displayed signal level is low, which is caused by gain compression. A 1dB (or 0.5dB) expression point is expressed typically with the input level corresponding to the output linear value deviation of 1dB (or 0.5dB).

### Detector detection mode

Refers to a display detector for signal energy. Each displayed point corresponds to a plurality of detected sample data points of a video signal in a portion of a frequency span or time interval represented by the point, and extracts a maximum of the data points and the minimum value, the two points are connected by a vertical line when displaying the trace. Such a detector can intuitively analyze the fluctuation range of the noise signal, and the display noise band can be widened by extending the sweep time.

### Positive peak detection mode

A display detection method for signal energy, each displayed point corresponds to a plurality of detected sample data points of a video signal in a portion of a frequency span or time interval represented by the point, and then the maximum of the data points is extracted, which is called positive peak detection

### IF gain/IF attenuation

The IF gain/IF attenuation is an IF controller that adjusts the vertical position of the signal on the display without affecting the signal level on the input mixer. If the IF gain/IF attenuation is changed, the reference level also changes accordingly.

## Annex B Zoom table of SCPI commands

Table 2 Zoom table of common SCPI commands

Command	Function
*CLS	Clear the instrument status data structure
*ESE	Set the standard event status enable register
*ESE?	Query the standard event status enable register
*ESR?	Read the event status register value
*IDN?	Read the instrument identification information
*OPC	Set operation register bits
*OPC?	Synchronous command, waiting for the operation to complete and return 1
*RST	Reset to startup initialization state
*SRE	Set the service request register
*SRE?	Query the service request register
*STB?	Query state byte
*TST?	Perform self-test
*WAI	Synchronous command, usually used in conjunction with INIT
:CONFigure?	Query current measurement function
:CONFigure:SANalyzer ACPower HARMonics OBWidth PSTatistic SEMask SPURious TOI BPOWer	Switch between various measurement functions
:FORMat:TRACe[:DATA] ASCii INTEger,32 REAL,32 REAL,64	Set trace data type (remote control only)
:FORMat:TRACe[:DATA]?	Query trace data type (remote control only)
:INPut:COUPling AC DC	Set coupling type
:INPut:COUPling?	Query coupling type
:INSTrument:CATalog?	Option query
:INPut:IMPedance 50 75	Impedance setting
:INSTrument:CREate[:NEW] <S>, <S>	Create measurement function
:INSTrument:DELeTe <S>	Delete measurement function
:INSTrument:LIST?	Query all current functions
:INSTrument[:SELeCt] SA BASIC  PNOISE  CWLAN PULSE VSA TA :INSTrument[:SELeCt] <S> :INSTrument[:SELeCt]?	Two switching mode methods and queries
:MMEMory:LOAD:STATe <filename>	LoadStateFile
:MMEMory:STORe:STATe <filename>	Save state file

## Annex B Zoom table of SCPI commands

:MMEMory:LOAD:CORRection 1 2 3 4 5 6, <filename>	Call amplitude correction
:MMEMory:LOAD:TRACe:DATA TRACE1 TRACE2 TRACE3  TRACE4  TRACE5  TRACE6, <filename>	Trace file call
:MMEMory:STORe:CORRection 1 2 3 4 5 6, <filename>	Save amplitude correction
:MMEMory:STORe:SCReen <filename>	Save screen shot
:MMEMory:DATA? <filename>	File transmission
:MMEMory:DELeTe <filename>	Delete file
[:SENSe]:CORRection:CSET[1] 2 3 4 5 6[:STATe] ON OFF 1 0	Set amplitude correction current correction ON/OFF
[:SENSe]:CORRection:CSET[1] 2 3 4 5 6[:STATe]?	Query amplitude correction current correction ON/OFF
[:SENSe]:CORRection:CSET[1] 2 3 4 5 6:DELeTe	Delete current amplitude correction
[:SENSe]:CORRection:CSET:ALL[:STATe] ON OFF 1 0	Apply all correction ON/OFF
[:SENSe]:CORRection:CSET:ALL[:STATe]?	Query and apply all correction ON/OFF
[:SENSe]:CORRection:CSET:ALL:DELeTe	Delete all corrections
[:SENSe]:FEED RF AREFereNce	Set input port
[:SENSe]:FEED?	Query input port
[:SENSe]:FEED:AREFereNce REF500 REFCOMB REF4800 REF9600 OFF	Set calibration port
[:SENSe]:FEED:AREFereNce?	Query calibration port
[:SENSe]:ROSCillator:SOURce INTernal EXTernal E10 E100 E1000	Set frequency reference internal and external
[:SENSe]:ROSCillator:SOURce?	Query frequency reference internal and external
:STATus:OPERation:CONDition?	Operation register state query
:STATus:OPERation:ENABle <Addr> :STATus:OPERation:ENABle?	Operation register enable
:STATus:OPERation[:EVENt]?	Operation register event query
:STATus:OPERation:NTRansition <Addr> :STATus:OPERation:NTRansition?	Negative jump of operation register
:STATus:OPERation:PTRansition <Addr> :STATus:OPERation:PTRansition?	Positive jump of operation register
:STATus:QUEStionable:CONDition?	Question register state query
:STATus:QUEStionable:ENABle <Addr> :STATus:QUEStionable:ENABle?	Question register enable
:STATus:QUEStionable [:EVENt]?	Question register event query
:STATus:QUEStionable:NTRansition <Addr> :STATus:QUEStionable:NTRansition?	Negative jump of question register

**Annex B Zoom table of SCPI commands**

:STATus:QUESTionable:PTRansition <Addr> :STATus:QUESTionable:PTRansition?	Positive jump of question register
:STATus:QUESTionable: CALibration:CONDition?	Question calibration register state query
:STATus:QUESTionable: CALibration:ENABle <Addr> :STATus:QUESTionable: CALibration:ENABle?	Question calibration register enable
:STATus:QUESTionable: CALibration [:EVENT]?	Question calibration register event query
:STATus:QUESTionable:CALibration:NTRansition <Addr> :STATus:QUESTionable:CALibration:NTRansition?	Negative jump of question calibration register
:STATus:QUESTionable:CALibration:PTRansition <Addr> :STATus:QUESTionable:CALibration:PTRansition?	Positive jump of question calibration register
:STATus:QUESTionable:FREQuency:CONDition?	Question frequency register state query
:STATus:QUESTionable: FREQuency:ENABle <Addr> :STATus:QUESTionable: FREQuency:ENABle?	Question frequency register enable
:STATus:QUESTionable: FREQuency[:EVENT]?	Question frequency register event query
:STATus:QUESTionable: FREQuency:NTRansition <Addr> :STATus:QUESTionable: FREQuency:NTRansition?	Negative jump of question frequency register
:STATus:QUESTionable: FREQuency:PTRansition <Addr> :STATus:QUESTionable: FREQuency:PTRansition?	Positive jump of question frequency register
:STATus:QUESTionable:POWer:CONDition?	Question power register state query
:STATus:QUESTionable: POWer:ENABle <Addr> :STATus:QUESTionable: POWer:ENABle?	Question power register enable
:STATus:QUESTionable: POWer [:EVENT]?	Question power register event query
:STATus:QUESTionable: POWer:NTRansition <Addr> :STATus:QUESTionable: POWer:NTRansition?	Negative jump of question power register
:STATus:QUESTionable: POWer:PTRansition <Addr> :STATus:QUESTionable: POWer:PTRansition?	Positive jump of question power register
:SYSTem:CLOGging ON OFF	Set log file ON/OFF
:SYSTem:CLOGging?	Query log file ON/OFF
:SYSTem:COMMunicate:GPIB[:SELF]:ADDRess <integer>	Set the GPIB address
:SYSTem:COMMunicate:GPIB[:SELF]:ADDRess?	Query the GPIB address
:SYSTem:COMMunicate:TCPIP:CONTrol <value>	Set the network port number
:SYSTem:COMMunicate:TCPIP:CONTrol?	Query network port number
:SYSTem:ERRor[:NEXT]?	Query current error information
:SYSTem:LOFF	Turn off the instrument
:SYSTem:OPTions?	Option query

## Annex B Zoom table of SCPI commands

:SYSTem:PRESet	Function Reset
:SYSTem:PRESet:USER	Change the reset mode to user reset
:SYSTem:PRESet:USER:SAVE	Save user resetting state
:SYSTem:APPLication:CATalog:OPTion?	System option query
:SYSTem:PUP:PROcess	Restart the instrument
:SYSTem:REMOte:CANcel	Cancel remote control marker

Table 3 Zoom table of sweep frequency analysis SCIP commands

Command	Function
:CALCulate:BWIDth BANDwidth:NDB <rel_amp>	NdB setting
:CALCulate:BWIDth BANDwidth:NDB?	NdB setting query
:CALCulate:BWIDth BANDwidth[:STATe] OFF ON 0 1	NdB measurement ON/OFF
:CALCulate:BWIDth BANDwidth[:STATe]?	NdB measurement switch query
:CALCulate:BWIDth BANDwidth:RESult?	NdB results query
:CALCulate:MARKer:TRCKing[:STATe] OFF ON 0 1	Set signal tracking
:CALCulate:MARKer:TRCKing[:STATe]?	Query signal tracking
:CALCulate:MARKer[1] 2--12:MAXimum	Peak Search
:CALCulate:MARKer[1] 2--12:MAXimum:NEXT	Sub Peak
:CALCulate:MARKer[1] 2--12:MAXimum:RIGHT	Right Peak
:CALCulate:MARKer[1] 2-12:MAXimum:LEFT	Left Peak
:CALCulate:MARKer:PEAK:EXCursion <rel_amp>	Set peak definition
:CALCulate:MARKer:PEAK:EXCursion?	Query peak definition
:CALCulate:MARKer:PEAK:EXCursion:STATe OFF ON 0 1	Set peak definition ON/OFF
:CALCulate:MARKer:PEAK:EXCursion:STATe?	Query peak definition ON/OFF
:CALCulate:MARKer:PEAK:THReshold <ampl>	Set peak threshold
:CALCulate:MARKer:PEAK:THReshold?	Query peak threshold
:CALCulate:MARKer:PEAK:THReshold:STATe OFF ON 0 1	Set peak threshold ON/OFF
:CALCulate:MARKer:PEAK:THReshold:STATe?	Query peak threshold ON/OFF
:CALCulate:MARKer:PEAK:TABLE:STATe OFF ON 0 1	Set peak table ON/OFF
:CALCulate:MARKer:PEAK:TABLE:STATe?	Query peak table ON/OFF
:CALCulate:MARKer:PEAK:SORT FREquency AMPLitude	Set peak sort
:CALCulate:MARKer:PEAK:SORT?	Query peak sort

**Annex B Zoom table of SCPI commands**

:CALCulate:MARKer:PEAK:TABLE:READout ALL GTDLine LTDLine	Set peak readout
:CALCulate:MARKer:PEAK:TABLE:READout?	Query peak readout
:CALCulate:MARKer[1] 2--12:CPSearch[:STATe] ON OFF 1 0	Set peak tracking ON/OFF
:CALCulate:MARKer[1] 2--12:CPSearch[:STATe]?	Query peak tracking ON/OFF
:CALCulate:MARKer[1] 2--12:PTPeak	Peak-to-peak search
:CALCulate:MARKer[1] 2--12:MINimum	Minimum Search
:CALCulate:MARKer[1] 2--12:MODE POSition DELTA FIXed OFF	Set marker mode
:CALCulate:MARKer[1] 2--12:MODE?	Query marker mode
:CALCulate:MARKer[1] 2--12:X <freq>	Set marker X-axis position
:CALCulate:MARKer[1] 2--12:X?	Query marker X-axis position
:CALCulate:MARKer[1] 2--12:X:POSition <real>	Set marker X point
:CALCulate:MARKer[1] 2--12:X:POSition?	Query marker X point
:CALCulate:MARKer[1] 2--12:Y <real>	Set marker Y-axis position
:CALCulate:MARKer[1] 2--12:Y?	Query marker Y-axis position
:CALCulate:MARKer[1] 2--12:REference <integer>	Set marker reference
:CALCulate:MARKer[1] 2--12:REference?	Query marker reference
:CALCulate:MARKer[1] 2--12:TRACe 1 2 3 4 5 6	Set marker trace
:CALCulate:MARKer[1] 2--12:TRACe?	Query marker trace
:CALCulate:MARKer[1] 2--12:LINes[:STATe] OFF ON 0 1	Set marker line display ON/OFF
:CALCulate:MARKer[1] 2--12:LINes[:STATe]?	Query marker line display ON/OFF
:CALCulate:MARKer:TABLE[:STATe] OFF ON 0 1	Set marker report window ON/OFF
:CALCulate:MARKer:TABLE[:STATe]?	Query marker report window ON/OFF
:CALCulate:MARKer[1] 2--12:FCOunt[:STATe] OFF ON 0 1	Set Marker Counter ON/OFF
:CALCulate:MARKer[1] 2--12:FCOunt[:STATe]?	Query Marker Counter ON/OFF
:CALCulate:MARKer[1] 2--12:FCOunt:X?	Query Marker Counter value
:CALCulate:MARKer[1] 2--12:FCOunt:GATetime <time>	Set Marker Counter Gating Time
:CALCulate:MARKer[1] 2--12:FCOunt:GATetime?	Query Marker Counter Gating Time
:CALCulate:MARKer[1] 2--12:FCOunt:GATetime:AUTO OFF ON 0 1	Set Marker Counter Gating Time Auto/Manual ON/OFF
:CALCulate:MARKer[1] 2--12:FCOunt:GATetime:AUTO?	Query Marker Counter Gating Time Auto/Manual ON/OFF
:CALCulate:MARKer:COUPle[:STATe] OFF ON 0 1	Set marker association
:CALCulate:MARKer:COUPle[:STATe]?	Query Marker Association
:CALCulate:MARKer:AOFF	Set to turn off all markers
:CALCulate:MARKer[1] 2--12:FUNCTION NOISe BPOWer BDENsity OFF	Set marker function

## Annex B Zoom table of SCPI commands

:CALCulate:MARKer[1]2--12:FUNCTION?	Query marker function
:CALCulate:MARKer[1]2--12:FUNCTION:BAND:SPAN <freq>	Set bandwidth adjustment span
:CALCulate:MARKer[1]2--12:FUNCTION:BAND:SPAN?	Query bandwidth adjustment span
:CALCulate:MARKer[1]2--12:FUNCTION:BAND:LEFT <freq>	Set bandwidth adjustment start frequency
:CALCulate:MARKer[1]2--12:FUNCTION:BAND:LEFT?	Query bandwidth adjustment start frequency
:CALCulate:MARKer[1]2--12:FUNCTION:BAND:RIGHT <freq>	Set bandwidth adjustment stop frequency
:CALCulate:MARKer[1]2--12:FUNCTION:BAND:RIGHT?	Query bandwidth adjustment stop frequency
:CALCulate:MARKer[1]2--12 [:SET]:CENTER	Marker → Center
:CALCulate:MARKer[1]2--12 [:SET]:STEP	Marker->Freq Step
:CALCulate:MARKer[1]2--12 [:SET]:START	Marker → Start
:CALCulate:MARKer[1]2--12 [:SET]:STOP	Marker → Stop
:CALCulate:MARKer[1]2--12 [:SET]:DELTA:SPAN	Marker Delta->Span
:CALCulate:MARKer[1]2--12 [:SET]:DELTA:CENTER	Delta Marker → Center
:CALCulate:MARKer[1]2--12 [:SET]:RLEVEL	Marker → Ref
:CONFigure?	Query measurement function
:CONFigure:SANalyzer	Set as spectrum measurement
:CONFigure:SANalyzer:NDEFault	Enter spectrum measurement in default state
:COUPle ALL	Set Associate All
:DEModAM FMOFF	Set audio demodulation type
:DEMod?	Query audio demodulation type.
:DISPlay:WINDow[1]:TRACe:Y[:SCALE]:PDIVision <rel_ampl>	SetScalePDiv
:DISPlay:WINDow[1]:TRACe:Y[:SCALE]:PDIVision?	QueryScalePDiv
:DISPlay:WINDow[1]:TRACe:Y[:SCALE]:RLEVEL <real>	Set reference level
:DISPlay:WINDow[1]:TRACe:Y[:SCALE]:RLEVEL?	Query reference level
:DISPlay:WINDow[1]:TRACe:Y[:SCALE]:RLEVEL:OFFSet <rel_power>	Set reference level offset
:DISPlay:WINDow[1]:TRACe:Y[:SCALE]:RLEVEL:OFFSet?	Query reference level offset
:DISPlay:WINDow[1]:TRACe:Y[:SCALE]:SPACing LINear LOGarithmic	SetAmplitudeScaleType
:DISPlay:WINDow[1]:TRACe:Y[:SCALE]:SPACing?	QueryAmplitudeScaleType
:DISPlay:WINDow[1]:TRACe:Y:DLINe <ampl>	Set display line
:DISPlay:WINDow[1]:TRACe:Y:DLINe?	Query display line
:DISPlay:WINDow[1]:TRACe:Y:DLINe:STATe OFF ON 0 1	Set display line ON/OFF
:DISPlay:WINDow[1]:TRACe:Y:DLINe:STATe?	Query display line ON/OFF
:FETCh:SANalyzer[n]?	Return the measurement results, which vary depending on the value

## Annex B Zoom table of SCPI commands

	of n
:INITiate:CONTinuous OFF ON 0 1	Set Single/Continuous
:INITiate:CONTinuous?	Query Single/Continuous
:INITiate:SANalyzer	Spectrum analysis initialization
:INITiate[:IMMediate]	Refresh now
:INITiate:PAUS	Pause measurement
:INITiate:RES	Resume measurement
:INITiate:REStart	Restart
:INPut:FILTer:YIG[:STATe] OFF ON 0 1	Set preselector bypass ON/OFF
:INPut:FILTer:YIG[:STATe]?	Query preselector bypass ON/OFF
:MEASure:SANalyzer[n]?	Perform spectrum measurement in default state
:READ:SANalyzer[n]?	Return the measurement results, which vary depending on the value of n
[:SENSe]:ADC:DITHer[:STATe] OFF ON HIGH	Set ADC ON/OFF
[:SENSe]:ADC:DITHer[:STATe]?	Query ADC ON/OFF
[:SENSe]:ADC:DITHer:AUTO[:STATe] OFF ON 0 1	Set ADC Auto/Manual ON/OFF
[:SENSe]:ADC:DITHer:AUTO[:STATe]?	Query ADC Auto/Manual ON/OFF
[:SENSe] :ADJust:LEVel	Set amplitude automatic scale
[:SENSe]:AVERage:COUNT <integer>	Set average times
[:SENSe]:AVERage:COUNT?	Query average times
[:SENSe]:AVERage:CLEar	Current Average Times Zero
[:SENSe]:AVERage:TYPE:AUTO OFF ON 0 1	Average Type Auto ON/OFF
[:SENSe]:AVERage:TYPE:AUTO?	Query Average Type Auto ON/OFF
[:SENSe]:AVERage:TYPE RMS LOG SCALar	Set average type
[:SENSe]:AVERage:TYPE?	Query average type
[:SENSe]:BANDwidth BWIDth[:RESolution] <freq>	Set resolution bandwidth
[:SENSe]:BANDwidth BWIDth[:RESolution]?	Query resolution bandwidth
[:SENSe]:BANDwidth BWIDth[:RESolution]:AUTO OFF ON 0 1	Set the resolution bandwidth Auto/Manual ON/OFF
[:SENSe]:BANDwidth BWIDth[:RESolution]:AUTO?	Query the resolution bandwidth Auto/Manual ON/OFF
[:SENSe]:BANDwidth BWIDth:VIDeo <freq>	Set VBW
[:SENSe]:BANDwidth BWIDth:VIDeo?	Query VBW
[:SENSe]:BANDwidth BWIDth:VIDeo:AUTO OFF ON 0 1	Set VBW Auto/Manual
[:SENSe]:BANDwidth BWIDth:VIDeo:AUTO?	Query VBW Auto/Manual
[:SENSe]:BANDwidth BWIDth:VIDeo:RATio <real>	Set VBW/RBW

## Annex B Zoom table of SCPI commands

[:SENSe]:BANDwidth BWIDth:VIDeo:RATio?	Query VBW/RBW
[:SENSe]:BANDwidth BWIDth:VIDeo:RATio:AUTO OFF ON 0 1	Set VBW/RBW ON/OFF
[:SENSe]:BANDwidth BWIDth:VIDeo:RATio:AUTO?	Query VBW/RBW
[:SENSe]:BANDwidth BWIDth:SHAPE GAUSSian FLATtop EMI6db CISPr	Set the filter type
[:SENSe]:BANDwidth BWIDth:SHAPE?	Query filter type
[:SENSe]:BANDwidth BWIDth:TYPE DB3 DB6	Set filter bandwidth
[:SENSe]:BANDwidth BWIDth:TYPE?	Query filter bandwidth
[:SENSe]:CORRection:NOISe:FLOOr ON OFF 1 0	Set noise extension switch
[:SENSe]:CORRection:NOISe:FLOOr?	Query noise extension ON/OFF
[:SENSe]:DETEctor:TRACe[1] 2--6 AVERAge NEGAtive NORMal POSitive SAMPle QPEak EAVERage  RAVERage	Set trace detection mode
[:SENSe]:DETEctor:TRACe[1] 2--6?	Query trace detection method settings
[:SENSe]:DETEctor[:FUNCTion] NORMal AVERAge POSitive SAMPle NEGAtive QPEak EAVERage  EPOSitive MPOSitive RMS	Set trace detection method settings (Valid for all traces)
[:SENSe]:DETEctor[:FUNCTion]?	Query trace detection method settings (Valid for all traces)
[:SENSe]:DETEctor:TRACe[1] 2--6:AUTO ON OFF 1 0	Set detection Auto/Manual ON/OFF
[:SENSe]:DETEctor:TRACe[1] 2--6:AUTO?	Query detection Auto/Manual ON/OFF
[:SENSe]:DETEctor:AUTO ON OFF 1 0	Set detection mode Auto/Manual ON/OFF (for all traces)
[:SENSe]:DETEctor:AUTO?	Query detection mode Auto/Manual ON/OFF (for all trace)
[:SENSe]:FREQuency:TUNE:IMMEdiate	Perform automatic tuning
[:SENSe]:FREQuency:STARt <freq>	Set start frequency
[:SENSe]:FREQuency:STARt?	Query start frequency
[:SENSe]:FREQuency:STOP <freq>	Set stop frequency
[:SENSe]:FREQuency:STOP?	Query stop frequency
[:SENSe]:FREQuency:SPAN:BANDwidth[:RESolution]:RATio <integer>	Set Span/RBW
[:SENSe]:FREQuency:SPAN:BANDwidth[:RESolution]:RATio?	Query Span/RBW
[:SENSe]:FREQuency:SPAN:BANDwidth[:RESolution]:RATio:AUTO OFF ON 0 1	Set Span/RBW ON/OFF
[:SENSe]:FREQuency:SPAN:BANDwidth[:RESolution]:RATio:AUTO?	Query Span/RBW
[:SENSe]:FREQuency:SPAN <freq>	Set span
[:SENSe]:FREQuency:SPAN?	Query span

**Annex B Zoom table of SCPI commands**

[;SENSe]:FREQuency:SPAN:FULL	Set full span
[;SENSe]:FREQuency:SPAN:PREVious	Query Set Previous Span
[;SENSe]:POWer[:RF]:MW:PATH STD LNPath	Set low noise path ON/OFF
[;SENSe]:POWer[:RF]:MW:PATH?	Query low noise path ON/OFF
[;SENSe]:RF:GAIN:AUTO:RULEs RANGE	RF Gain Dynamic Range Priority
[;SENSe]:RF:GAIN:AUTO:RULEs SENSITIVITY	Set RF Gain to Sensitivity Priority
[;SENSe]:RF:GAIN:AUTO:RULEs?	Query RF gain allocation rules
[;SENSe]:RF:GAIN:AUTO[:STATe] OFF ON 0 1	Set RF gain Auto/Manual ON/OFF
[;SENSe]:RF:GAIN:AUTO[:STATe]?	Query RF gain Auto/Manual ON/OFF
[;SENSe]:SWEep:FFT:WIDTh <real>	Set FFT width
[;SENSe]:SWEep:FFT:WIDTh?	Query FFT width
[;SENSe]:SWEep:FFT:WIDTh:AUTO OFF ON 0 1	Set FFT width Auto/Manual ON/OFF
[;SENSe]:SWEep:FFT:WIDTh:AUTO?	Query FFT width Auto/Manual ON/OFF
[;SENSe]:SWEep:TIME <time>	Set SwpTime
[;SENSe]:SWEep:TIME?	QuerySwpTime
[;SENSe]:SWEep:TIME:AUTO OFF ON 0 1	Set sweep time ON/OFF
[;SENSe]:SWEep:TIME:AUTO?	QuerySwpTime
[;SENSe]:SWEep:TIME:AUTO:RULEs NORMAl ACCuracy SRESponse	Set sweep time rule
[;SENSe]:SWEep:TIME:AUTO:RULEs?	Query sweep time rule
[;SENSe]:SWEep:TYPE FFT SWEep	SetSwpType
[;SENSe]:SWEep:TYPE?	QuerySwpType
[;SENSe]:SWEep:TYPE:AUTO OFF ON 0 1	Set sweep type Auto/Manual
[;SENSe]:SWEep:TYPE:AUTO?	Query sweep type Auto/Manual
[;SENSe]:SWEep:TYPE:AUTO:RULEs AUTO SPEed DRANge	Set sweep type rule
[;SENSe]:SWEep:TYPE:AUTO:RULEs?	Query sweep type rule
[;SENSe]:SWEep:POINts <integer>	Set number of sweep points
[;SENSe]:SWEep:POINts?	Query number of sweep points
:TRACe[1]2-6:DISPlay[:STATe] ON OFF 0 1	Set trace display state ON/OFF
:TRACe[1]2-6:DISPlay[:STATe]?	Query trace display state ON/OFF
:TRACe:PRESet:ALL	Reset all traces
:TRACe[1]2-6:TYPE WRITe AVERAge MAXHold MINHold	Set trace display mode
:TRACe[1]2-6:TYPE?	Query trace display mode
:TRACe#:UPDate[:STATe] ON OFF 0 1	Set trace update state ON/OFF

## Annex B Zoom table of SCPI commands

:TRACe#:UPDate[:STATe]?	Query trace update state ON/OFF
:TRACe[:DATA]? TRACE1 TRACE2 TRACE3 TRACE4 TRACE5 TRACE6	Query trace data (remote control only)
:UNIT:POWer DBM DBMV DBMA V W A DBUV DBUA	Set Y-axis scale units
:UNIT:POWer?	Query Y-axis scale units
:INITiate:PAUSe	Pause sweep
:INITiate:RESume	Restore sweep
[:SENSe]:FREQuency:CENTer <freq>	Set center frequency
[:SENSe]:FREQuency:CENTer?	Query center frequency
[:SENSe]:FREQuency:CENTer:STEP[:INCRement] <freq>	Set the frequency step
[:SENSe]:FREQuency:CENTer:STEP[:INCRement]?	Query frequency step
[:SENSe]:FREQuency:CENTer:STEP:AUTO OFF ON 0 1	Set frequency step Auto/Manual ON/OFF
[:SENSe]:FREQuency:CENTer:STEP:AUTO?	Query frequency step Auto/Manual ON/OFF
[:SENSe]:FREQuency:OFFSet <freq>	Set frequency offset
[:SENSe]:FREQuency:OFFSet?	Query frequency offset
[:SENSe]:POWer[:RF]:ATTenuation <rel_ampl>	Set mechanical attenuation
[:SENSe]:POWer[:RF]:ATTenuation?	Query mechanical attenuation
[:SENSe]:POWer[:RF]:ATTenuation:AUTO OFF ON 0 1	Set mechanical attenuation Auto/Manual ON/OFF
[:SENSe]:POWer[:RF]:ATTenuation:AUTO?	Query mechanical attenuation Auto/Manual ON/OFF
[:SENSe]:POWer[:RF]:EATTenuation <rel_ampl>	Set electronic attenuation
[:SENSe]:POWer[:RF]:EATTenuation?	Query electronic attenuation
[:SENSe]:POWer[:RF]:EATTenuation:STATe OFF ON 0 1	Set electronic attenuator ON/OFF
[:SENSe]:POWer[:RF]:EATTenuation:STATe?	Query electronic attenuator ON/OFF
[:SENSe]:POWer[:RF]:EATTenuation <rel_ampl>	Set electronic attenuator
[:SENSe]:POWer[:RF]:EATTenuation?	Query electronic attenuator
[:SENSe]:POWer[:RF]:ATTenuation:STEP[:INCRement] 10dB 2dB	Set mechanical attenuation step
[:SENSe]:POWer[:RF]:ATTenuation:STEP[:INCRement]?	Query mechanical attenuation step
[:SENSe]:POWer[:RF]:MIXer:RANGe[:UPPer] <real>	Set maximum mixing level
[:SENSe]:POWer[:RF]:MIXer:RANGe[:UPPer]?	Query maximum mixing level
[:SENSe]:POWer[:RF]:GAIN[:STATe] OFF ON 0 1	SetPreAmpSwitch
[:SENSe]:POWer[:RF]:GAIN[:STATe]?	QueryPreAmpSwitch
[:SENSe]:SWEep:EGATe:HOLDoff <time>	Set trigger OFF time
[:SENSe]:SWEep:EGATe:HOLDoff?	Query trigger block time
[:SENSe]:SWEep:EGATe:HOLDoff:AUTO OFF ON 0 1	Set trigger block ON/OFF

**Annex B Zoom table of SCPI commands**

[;SENSe]:SWEep:EGATe:HOLDoff:AUTO?	Query trigger block ON/OFF
:TRIGger[:SEQuence]:EXTernal[1]2 3:DELay <time>	Set trigger delay ON/OFF of External Trigger 1, External Trigger 2, and External Trigger 3
:TRIGger[:SEQuence]:EXTernal[1]2 3:DELay?	Query trigger delay of External Trigger 1, External Trigger 2, and External Trigger 3
:TRIGger[:SEQuence]:EXTernal[1]2 3:DELay:STATe OFF ON 0 1	Set trigger delay ON/OFF of External Trigger 1, External Trigger 2, and External Trigger 3
:TRIGger[:SEQuence]:EXTernal[1]2 3:DELay:STATe?	Query trigger delay ON/OFF of External Trigger 1, External Trigger 2, and External Trigger 3
:TRIGger[:SEQuence]:EXTernal[1]2:LEVel <level>	Set trigger level of External Trigger 1 or External Trigger 2
:TRIGger[:SEQuence]:EXTernal[1]2:LEVel?	Query trigger level of External Trigger 1 or External Trigger 2
:TRIGger[:SEQuence]:EXTernal[1]2 3:SLOPe POSitive NEGative	Set the Trigger Slope of External Trigger 1, External Trigger 2, and External Trigger 3
:TRIGger[:SEQuence]:EXTernal[1]2 3:SLOPe?	Query the Trigger Slope of External Trigger 1, External Trigger 2, and External Trigger 3
:TRIGger[:SEQuence]:FRAMe:DELay <time>	Set Time Trigger delay
:TRIGger[:SEQuence]:FRAMe:DELay?	Query Time Trigger delay
:TRIGger[:SEQuence]:FRAMe:DELay:STATe OFF ON 0 1	Set Trigger Delay ON/OFF of Trigger Timer
:TRIGger[:SEQuence]:FRAMe:DELay:STATe?	Query Trigger Delay ON/OFF of Trigger Timer
:TRIGger[:SEQuence]:FRAMe:OFFSet <time>	Set Time Trigger Offset
:TRIGger[:SEQuence]:FRAMe:OFFSet?	Query Time Trigger Offset
:TRIGger[:SEQuence]:FRAMe:PERiod <time>	Set Time Trigger Cycle
:TRIGger[:SEQuence]:FRAMe:PERiod?	Query Time Trigger Cycle
:TRIGger[:SEQuence]:FRAMe:SYNC EXTernal1 EXTernal2 RFBurst OFF	Sync Source Selection
:TRIGger[:SEQuence]:FRAMe:SYNC?	Query Synchronization Source Selection
:TRIGger[:SEQuence]:FRAMe:SYNC:HOLDoff <time>	Set synchronization source blocking
:TRIGger[:SEQuence]:FRAMe:SYNC:HOLDoff?	Query synchronization source blocking
:TRIGger[:SEQuence]:LINE:DELay <time>	Set power trigger delay
:TRIGger[:SEQuence]:LINE:DELay?	Query power trigger delay
:TRIGger[:SEQuence]:LINE:DELay:STATe OFF ON 0 1	Set power trigger delay ON/OFF
:TRIGger[:SEQuence]:LINE:DELay:STATe?	Query power trigger delay ON/OFF
:TRIGger[:SEQuence]:LINE:SLOPe POSitive NEGative	Set Power Trigger Slope
:TRIGger[:SEQuence]:LINE:SLOPe?	Query Power Trigger Slope
:TRIGger[:SEQuence]:RFBurst:DELay <time>	Set trigger delay of burst signal

## Annex B Zoom table of SCPI commands

:TRIGger[:SEQuence]:RFBurst:DELay?	Query trigger delay of burst signal
:TRIGger[:SEQuence]:RFBurst:DELay:STATe OFF ON 0 1	Set trigger delay ON/OFF of burst signal
:TRIGger[:SEQuence]:RFBurst:DELay:STATe?	Query trigger delay ON/OFF of burst signal
:TRIGger[:SEQuence]:RFBurst:LEVel:ABSolute <ampl>	Set burst signal trigger level
:TRIGger[:SEQuence]:RFBurst:LEVel:ABSolute?	Query burst signal trigger level
:TRIGger[:SEQuence]:RFBurst:SLOPe POSitive NEGative	Set Trigger Slope of Burst Signal Trigger
:TRIGger[:SEQuence]:RFBurst:SLOPe?	Query Trigger Slope of Burst Signal Trigger
:TRIGger[:SEQuence]:SOURce EXTernal1 EXTernal2 EXTernal3 IMMediate LINE FRAME RFBurst VIDeo	Trigger Mode Selection
:TRIGger[:SEQuence]:SOURce?	Query Trigger Mode Selection
:TRIGger[:SEQuence]:VIDeo:DELay <time>	Set video trigger delay
:TRIGger[:SEQuence]:VIDeo:DELay?	Query video trigger delay
:TRIGger[:SEQuence]:VIDeo:DELay:STATe OFF ON 0 1	Set video trigger delay
:TRIGger[:SEQuence]:VIDeo:DELay:STATe?	Query video trigger delay
:TRIGger[:SEQuence]:VIDeo:LEVel <ampl>	Set video trigger level
:TRIGger[:SEQuence]:VIDeo:LEVel?	Query video trigger level
:TRIGger[:SEQuence]:VIDeo:SLOPe POSitive NEGative	Set Video Trigger Slope
:TRIGger[:SEQuence]:VIDeo:SLOPe?	Query Video Trigger Slope

Table 4 Zoom table of adjacent power SCPI commands

Command	Function
:CALCulate:ACPower:MARKer[1] 2--12:X:POSition <real>	Set marker X-axis value
:CALCulate:ACPower:MARKer:COUPl[e]:STATe OFF ON 0 1	Set Marker Association State
:CALCulate:ACPower:MARKer:COUPl[e]:STATe?	Query Marker Association State
:CALCulate:ACPower:MARKer:PEAK:EXCursion <rel_ampl>	Set peak definition
:CALCulate:ACPower:MARKer:PEAK:EXCursion:STATe OFF ON 0 1	Set peak definition state
:CALCulate:ACPower:MARKer:PEAK:EXCursion:STATe?	Query peak definition state
:CALCulate:ACPower:MARKer:PEAK:EXCursion?	Query peak definition
:CALCulate:ACPower:MARKer:PEAK:THReshold <ampl>	Set peak threshold
:CALCulate:ACPower:MARKer:PEAK:THReshold:STATe OFF ON 0 1	Set peak threshold state
:CALCulate:ACPower:MARKer:PEAK:THReshold:STATe?	Query peak threshold state
:CALCulate:ACPower:MARKer:PEAK:THReshold?	Query peak threshold
:CALCulate:ACPower:MARKer[1] 2--12:CPSearch[:STATe] ON OFF 1 0	Set continuous peak search state

**Annex B Zoom table of SCPI commands**

:CALCulate:ACPower:MARKer[1]2--12:CPSearch[:STATe]?	Query continuous peak search state
:CALCulate:ACPower:MARKer[1]2--12:LINes[:STATe] OFF ON 0 1	Set marker display line state
:CALCulate:ACPower:MARKer[1]2--12:LINes[:STATe]?	Query marker display line state
:CALCulate:ACPower:MARKer[1]2--12:MAXimum	Set peak search
:CALCulate:ACPower:MARKer[1]2--12:MAXimum:LEFT	Set left adjacent peak
:CALCulate:ACPower:MARKer[1]2--12:MAXimum:NEXT	Set sub peak
:CALCulate:ACPower:MARKer[1]2--12:MAXimum:RIGHT	Set right adjacent peak
:CALCulate:ACPower:MARKer[1]2--12:MINimum	Perform minimum search
:CALCulate:ACPower:MARKer[1]2--12:MODE DELTa	Setting delta markers
:CALCulate:ACPower:MARKer[1]2--12:MODE POSITION DELTA FIXed OFF	Set the type for the marker
:CALCulate:ACPower:MARKer[1]2--12:MODE?	Query the type for the marker
:CALCulate:ACPower:MARKer[1]2--12:MODE?	Query delta marker
:CALCulate:ACPower:MARKer[1]2--12:REFerence <integer>	Set reference marker
:CALCulate:ACPower:MARKer[1]2--12:REFerence?	Query reference marker
:CALCulate:ACPower:MARKer[1]2--12:TRACe 1 2 3 4 5 6	Set marker trace
:CALCulate:ACPower:MARKer[1]2--12:TRACe?	Query marker trace
:CALCulate:ACPower:MARKer[1]2--12:X <freq time>	Set marker X-axis value (frequency or time)
:CALCulate:ACPower:MARKer[1]2--12:X:POSITION?	Query marker X-axis value
:CALCulate:ACPower:MARKer[1]2--12:X?	Query marker X-axis value (frequency or time)
:CALCulate:ACPower:MARKer[1]2--12:Y <real>	Set marker Y-axis value
:CALCulate:ACPower:MARKer[1]2--12:Y?	Query the value of axis Y
:CALCulate:ACPower:MARKer[1]2--12[:SET]:CENTER	Set marker-to-center frequency
:CALCulate:ACPower:MARKer[1]2--12[:SET]:RLEVEL	Set marker-to-reference level
:CALCulate:MARKer[1]2--12:PTPeak	Perform peak to peak search
:CONFigure:ACPower	Enter adjacent channel power
:COUPle ALL	Set Auto All
:DISPlay:ACPower:VIEW:WINDow:BGRaph ON OFF 1 0	Set bar chart switch
:DISPlay:ACPower:VIEW:WINDow:BGRaph?	Query bar chart switch
:DISPlay:ACPower:WINDow:TRACe:Y:RLEVEL < ampl >	Set reference level
:DISPlay:ACPower:WINDow:TRACe:Y:RLEVEL?	Query reference level
:DISPlay:ACPower:WINDow[1]:TRACe:Y[:SCALE]:PDIVision <rel_ampl>	SetScalePDiv
:DISPlay:ACPower:WINDow[1]:TRACe:Y[:SCALE]:PDIVision?	QueryScalePDiv

## Annex B Zoom table of SCPI commands

:DISPlay:ACPower:WINDow[1]:TRACe:Y[:SCALe]:RLEVel:OFFSet?	Query reference level offset
:DISPlay:ACPower:WINDow[1]:TRACe:Y[:SCALe]:RLEVel:OFFSet <rel_ampl>	Set reference level offset
:DISPlay:WINDow[1]:TRACe:X:FLINe[1]2[...].6 <ampl>	Set frequency display line value
:DISPlay:WINDow[1]:TRACe:X:FLINe[1]2[...].6:STATe OFF ON 0 1	Set frequency display line state
:DISPlay:WINDow[1]:TRACe:X:FLINe[1]2[...].6:STATe?	Query frequency display line state
:DISPlay:WINDow[1]:TRACe:X:FLINe[1]2[...].6?	Query frequency display line value
:DISPlay:WINDow[1]:TRACe:X:TLINE[1]2[...].6 <ampl>	Set time display line value
:DISPlay:WINDow[1]:TRACe:X:TLINE[1]2[...].6:STATe OFF ON 0 1	Set time display line state
:DISPlay:WINDow[1]:TRACe:X:TLINE[1]2[...].6:STATe?	Query time display line state
:DISPlay:WINDow[1]:TRACe:X:TLINE[1]2[...].6?	Query time display line value
:DISPlay:WINDow[1]:TRACe:Y:DLINe[1]2[...].6 <ampl>	Set display line value
:DISPlay:WINDow[1]:TRACe:Y:DLINe[1]2[...].6:STATe OFF ON 0 1	Set selected display line state
:DISPlay:WINDow[1]:TRACe:Y:DLINe[1]2[...].6:STATe?	Query selected display line state
:DISPlay:WINDow[1]:TRACe:Y:DLINe[1]2[...].6?	Query display line value
:FETCh:ACPower[n]?	Fetch measurement results data
:INITiate:CONTInuous OFF ON 0 1	Set sweep mode as continuous sweep or single sweep
:INITiate:CONTInuous?	Query sweep mode
:MEASure:ACPower[n]?	Fetch measurement results data
:READ:ACPower[n]?	Fetch measurement results data
:TRACe[1]2--6:ACPower:DISPlay[:STATe] ON OFF 0 1	Set the Display Method of the Currently Selected Trace
:TRACe[1]2--6:ACPower:DISPlay[:STATe]?	Query the display method of the currently selected trace
:TRACe[1]2--6:ACPower:TYPE AVERAge	Set the Processing Method of the Currently Selected Trace to Average
:TRACe[1]2--6:ACPower:TYPE MAXHold	Set the Processing Method of the Currently Selected Trace to Max Hold
:TRACe[1]2--6:ACPower:TYPE MINHold	Set the Processing Method of the Currently Selected Trace to Min Hold
:TRACe[1]2--6:ACPower:TYPE WRITe	Set the Processing Method of the Currently Selected Trace to Refresh
:TRACe[1]2--6:ACPower:TYPE?	Query Set the Processing Method of the Currently Selected Trace
:TRACe[1]2--6:ACPower:UPDate[:STATe] ON OFF 0 1	Set the Update Method of the Currently Selected Trace
:TRACe[1]2--6:ACPower:UPDate[:STATe]?	Query the Update Method of the Currently Selected Trace
:UNIT:ACP:POWER?	Query vertical axis units

## Annex B Zoom table of SCPI commands

:UNIT:ACPower:POWer DBM DBMV DBMA V W A DBUV DBUA	Set vertical axis units
[:SENSe]:ACPower:ADC:DITHer:AUTO[:STATe] OFF ON 0 1	Set ADC Dither Auto/Manual
[:SENSe]:ACPower:ADC:DITHer:AUTO[:STATe]?	Query ADC Dither Auto/Manual
[:SENSe]:ACPower:ADC:DITHer[:STATe] OFF ON	Set ADC Dither
[:SENSe]:ACPower:ADC:DITHer[:STATe]?	Query ADC Dither
[:SENSe]:ACPower:ADJust:LEVel	Set automatic amplitude
[:SENSe]:ACPower:AVERAge:COUNt <integer>	Set average/hold times
[:SENSe]:ACPower:AVERAge:COUNt?	Query average/hold times
[:SENSe]:ACPower:AVERAge:TYPE RMS LOG SCALar	Set average type
[:SENSe]:ACPower:AVERAge:TYPE?	Query average type
[:SENSe]:ACPower:BANDwidth BWIDth:SHAPE GAUSSian FLATtop EMI6db CISPr	Set the filter type
[:SENSe]:ACPower:BANDwidth BWIDth:SHAPE?	Query filter type
[:SENSe]:ACPower:BANDwidth BWIDth:TYPE DB3 DB6	Set filter bandwidth
[:SENSe]:ACPower:BANDwidth BWIDth:TYPE?	Query filter bandwidth
[:SENSe]:ACPower:BANDwidth BWIDth:VIDeo <bandwidth>	Set VBW
[:SENSe]:ACPower:BANDwidth BWIDth:VIDeo:RATio <real>	Set VBW/RBW
[:SENSe]:ACPower:BANDwidth BWIDth:VIDeo:RATio:AUTO OFF ON 0 1	Set VBW/RBW Auto/Manual
[:SENSe]:ACPower:BANDwidth BWIDth:VIDeo:RATio:AUTO?	Query VBW/RBW Auto/Manual
[:SENSe]:ACPower:BANDwidth BWIDth:VIDeo:RATio?	Query VBW/RBW
[:SENSe]:ACPower:BANDwidth BWIDth:VIDeo?	Query VBW
[:SENSe]:ACPower:BANDwidth BWIDth[:RESolution] <bandwidth>	Set RBW
[:SENSe]:ACPower:BANDwidth BWIDth[:RESolution]?	Query RBW
[:SENSe]:ACPower:CARRier:COUNt <integer>	Set the number of carriers
[:SENSe]:ACPower:CARRier:COUNt?	Query the number of carriers
[:SENSe]:ACPower:CARRier:CPSD <real>	Set spectral density reference
[:SENSe]:ACPower:CARRier:CPSD?	Query spectral density reference
[:SENSe]:ACPower:CARRier:LIST:BANDwidth[:INTEgration] <freq>,...	Set carrier integral bandwidth
[:SENSe]:ACPower:CARRier:LIST:BANDwidth[:INTEgration]?	Query carrier integral bandwidth
[:SENSe]:ACPower:CARRier:LIST:FILTer:ALPHA <real>,...	Set carrier RRC filter a
[:SENSe]:ACPower:CARRier:LIST:FILTer:ALPHA?	Query carrier RRC filter a
[:SENSe]:ACPower:CARRier:LIST:FILTer[:RRC][:STATe]?	Querying carrier measurement methods
[:SENSe]:ACPower:CARRier:LIST:FILTer[:RRC][:STATe] ON OFF 1 0, ...	Set carrier measurement method

## Annex B Zoom table of SCPI commands

[[:SENSe]:ACPower:CARRier:LIST:WIDTh <bandwidth>,...	Set carrier spacing
[[:SENSe]:ACPower:CARRier:LIST:WIDTh?	Query carrier spacing
[[:SENSe]:ACPower:CARRier[:POWER] <real>	Set total power reference
[[:SENSe]:ACPower:CARRier[:POWER]?	Query total power reference
[[:SENSe]:ACPower:DETEctor[:FUNction] NORMal POSitive SAMPleNEGative AVERage RMS SCALar]	Set the Detection Type of the Currently Selected Trace
[[:SENSe]:ACPower:DETEctor[:FUNction]?	Query the Detection Type of the Currently Selected Trace
[[:SENSe]:ACPower:FREQuency:SPAN <frequency>	Set span
[[:SENSe]:ACPower:FREQuency:SPAN:BANDwidth[:RESolution]:RATio <integer>	Set Span/RBW
[[:SENSe]:ACPower:FREQuency:SPAN:BANDwidth[:RESolution]:RATio: AUTO OFF ON 0 1	Set Span/RBW Auto/Manual
[[:SENSe]:ACPower:FREQuency:SPAN:BANDwidth[:RESolution]:RATio: AUTO?	Query Span/RBW Auto/Manual
[[:SENSe]:ACPower:FREQuency:SPAN:BANDwidth[:RESolution]:RATio ?	Query Span/RBW
[[:SENSe]:ACPower:FREQuency:SPAN?	Query span
[[:SENSe]:ACPower:GAP:COUNT <integer>	Set the number of gaps
[[:SENSe]:ACPower:GAP:COUNT?	Query the number of gaps
[[:SENSe]:ACPower:GAP[1]]2--8:LIST:ABSolute <real>,...	Set gap channel absolute limit
[[:SENSe]:ACPower:GAP[1]]2--8:LIST:ABSolute?	Query gap channel absolute limit
[[:SENSe]:ACPower:GAP[1]]2--8:LIST:BANDwidth:RESolution <bandwidth>, ...	Set spacing channel resolution bandwidth
[[:SENSe]:ACPower:GAP[1]]2--8:LIST:BANDwidth:RESolution?	Query spacing channel resolution bandwidth
[[:SENSe]:ACPower:GAP[1]]2--8:LIST:BANDwidth:SHAPE GAUSSian FLATop,...	Set gap channel filter type
[[:SENSe]:ACPower:GAP[1]]2--8:LIST:BANDwidth:SHAPE?	Query gap channel filter type
[[:SENSe]:ACPower:GAP[1]]2--8:LIST:BANDwidth:TYPE DB3 DB6,...	Set gap channel filter bandwidth
[[:SENSe]:ACPower:GAP[1]]2--8:LIST:BANDwidth:TYPE?	Query gap channel filter bandwidth
[[:SENSe]:ACPower:GAP[1]]2--8:LIST:BANDwidth:VIDeo <freq>,...	Set gap channel video bandwidth
[[:SENSe]:ACPower:GAP[1]]2--8:LIST:BANDwidth:VIDeo?	Query gap channel video bandwidth
[[:SENSe]:ACPower:GAP[1]]2--8:LIST:BANDwidth[:INTegration] <bandwidth>,...	Set gap channel integral bandwidth
[[:SENSe]:ACPower:GAP[1]]2--8:LIST:BANDwidth[:INTegration]?	Query gap channel integral bandwidth
[[:SENSe]:ACPower:GAP[1]]2--8:LIST:FILTER:ALPHA <real>,...	Set gap channel RRC filter a

**Annex B Zoom table of SCPI commands**

[:SENSe]:ACPower:GAP[1]]2--8:LIST:FILTER:ALPHA?	Query gap channel RRC filter a
[:SENSe]:ACPower:GAP[1]]2--8:LIST:RCARrier <real>,...	Set gap channel relative limit
[:SENSe]:ACPower:GAP[1]]2--8:LIST:RCARrier?	Query gap channel relative limit
[:SENSe]:ACPower:GAP[1]]2--8:LIST:TEST ABSolute AND OR RELative,...	Set Gap Channel Limit Mask
[:SENSe]:ACPower:GAP[1]]2--8:LIST:TEST?	Query Gap Channel Limit Mask
[:SENSe]:ACPower:GAP[1]]2--8:LIST[:FREQuency] <freq>,...	Set gap channel offset frequency
[:SENSe]:ACPower:GAP[1]]2--8:LIST[:FREQuency]?	Query gap channel offset frequency
[:SENSe]:ACPower:GAP[1]]2--8:LOCation <integer>	Set gap position
[:SENSe]:ACPower:GAP[1]]2--8:LOCation?	Query gap position
[:SENSe]:ACPower:METHod IBW FAST RBW IBWRange	Set measurement method
[:SENSe]:ACPower:METHod?	Query measurement method
[:SENSe]:ACPower:MODE NORMAl MULTI	Set measurement mode
[:SENSe]:ACPower:MODE?	Query measurement mode
[:SENSe]:ACPower:OFFSet:LIST:ABSolute <real>,...	Set offset channel absolute limit
[:SENSe]:ACPower:OFFSet:LIST:ABSolute?	Query offset channel absolute limit
[:SENSe]:ACPower:OFFSet:LIST:BANDwidth:RESolution <bandwidth>, ...	Set offset channel RBW
[:SENSe]:ACPower:OFFSet:LIST:BANDwidth:RESolution?	Query offset channel RBW
[:SENSe]:ACPower:OFFSet:LIST:BANDwidth:SHAPE GAUSSian FLATtop,...	Set offset channel filter type
[:SENSe]:ACPower:OFFSet:LIST:BANDwidth:SHAPE?	Query offset channel filter type
[:SENSe]:ACPower:OFFSet:LIST:BANDwidth:TYPE DB3 DB6,...	Set offset channel filter bandwidth
[:SENSe]:ACPower:OFFSet:LIST:BANDwidth:TYPE?	Query offset channel filter bandwidth
[:SENSe]:ACPower:OFFSet:LIST:BANDwidth:VIDeo <freq>,...	Set offset channel video bandwidth
[:SENSe]:ACPower:OFFSet:LIST:BANDwidth:VIDeo?	Query offset channel video bandwidth
[:SENSe]:ACPower:OFFSet:LIST:BANDwidth[:INTegration] <bandwidth>,...	Set offset channel integral bandwidth
[:SENSe]:ACPower:OFFSet:LIST:BANDwidth[:INTegration]?	Query offset channel integral bandwidth
[:SENSe]:ACPower:OFFSet:LIST:FILTER:ALPHA <real>,...	Set offset channel RRC filter a
[:SENSe]:ACPower:OFFSet:LIST:FILTER:ALPHA?	Query offset channel RRC filter a
[:SENSe]:ACPower:OFFSet:LIST:RCARrier <real>,...	Set offset channel relative limit
[:SENSe]:ACPower:OFFSet:LIST:RCARrier?	Query offset channel relative limit
[:SENSe]:ACPower:OFFSet:LIST:TEST ABSolute AND OR RELative,...	Set Offset Channel Limit Mask

## Annex B Zoom table of SCPI commands

[:SENSe]:ACPower:OFFSet:LIST:TEST?	Query Offset Channel Limit Mask
[:SENSe]:ACPower:OFFSet:LIST[:FREQUENCY] <freq>,...	Set offset channel offset frequency
[:SENSe]:ACPower:OFFSet:LIST[:FREQUENCY]?	Query offset channel offset frequency
[:SENSe]:ACPower:SWEep:POINts <integer>	Set number of sweep points
[:SENSe]:ACPower:SWEep:POINts?	Query number of sweep points
[:SENSe]:ACPower:SWEep:TIME <time>	Set the sweep time of the signal/spectrum analyzer
[:SENSe]:ACPower:SWEep:TIME:AUTO OFF ON 0 1	Set the sweep time Auto/Manual of the signal/spectrum analyzer
[:SENSe]:ACPower:SWEep:TIME:AUTO ON	Set auto sweep time
[:SENSe]:ACPower:SWEep:TIME:AUTO:RULEs NORMal ACCuracy SRESPonse	Set sweep time rule
[:SENSe]:ACPower:SWEep:TIME:AUTO:RULEs?	Query sweep time rule
[:SENSe]:ACPower:SWEep:TIME:AUTO?	Query signal/spectrum analyzer sweep time Auto/Manual
[:SENSe]:ACPower:SWEep:TIME?	Query sweep time of the signal/spectrum analyzer
[:SENSe]:ACPower:SWEep:TYPE FFT SWEep	SetSwpType
[:SENSe]:ACPower:SWEep:TYPE:AUTO OFF ON 0 1	Set sweep type Auto/Manual
[:SENSe]:ACPower:SWEep:TYPE:AUTO:RULEs SPEed DRANge	Set sweep type rule
[:SENSe]:ACPower:SWEep:TYPE:AUTO:RULEs:AUTO[:STATE] OFF ON 0 1	Set sweep type rules Auto/Manual
[:SENSe]:ACPower:SWEep:TYPE:AUTO:RULEs:AUTO[:STATE]?	Query sweep type rules Auto/Manual
[:SENSe]:ACPower:SWEep:TYPE:AUTO:RULEs?	Query sweep type rule
[:SENSe]:ACPower:SWEep:TYPE:AUTO?	Query sweep type Auto/Manual
[:SENSe]:ACPower:SWEep:TYPE?	QuerySwpType
[:SENSe]:ACPower:TX1: FREQuence <freq>	Set carrier 1 frequency
[:SENSe]:ACPower:TX1: FREQuence?	Query carrier 1 frequency
[:SENSe]:ACPower:TYPE TPreff PSDRef	SetMeasTarget
[:SENSe]:ACPower:TYPE?	QueryMeasTarget
[:SENSe]:CORRection:NOISe:FLOOr ON OFF 1 0	Set noise extension
[:SENSe]:CORRection:NOISe:FLOOr?	Query noise extension
[:SENSe]:FREQUENCY:CENTer <frequency>	Set center frequency
[:SENSe]:FREQUENCY:CENTer:STEP:AUTO OFF ON 0 1	Set Freq Step Auto/Man
[:SENSe]:FREQUENCY:CENTer:STEP:AUTO?	Query Freq Step Auto/Man
[:SENSe]:FREQUENCY:CENTer:STEP[:INCRement] <freq>	Set the frequency step
[:SENSe]:FREQUENCY:CENTer:STEP[:INCRement]?	Query frequency step

**Annex B Zoom table of SCPI commands**

[;SENSe]:FREQuency:CENTer?	Obtain center frequency
[;SENSe]:FREQuency:OFFSet <freq>	Set frequency offset
[;SENSe]:FREQuency:OFFSet?	Query frequency offset
[;SENSe]:POWer[:RF]:ATTenuation <rel_power>	Set mechanical attenuator
[;SENSe]:POWer[:RF]:ATTenuation:AUTO OFF ON 0 1	Set mechanical attenuator Auto/Manual
[;SENSe]:POWer[:RF]:ATTenuation:AUTO?	Query mechanical attenuator Auto/Manual
[;SENSe]:POWer[:RF]:ATTenuation:STEP[:INCRement] 10dB 2dB	Set mechanical attenuator step
[;SENSe]:POWer[:RF]:ATTenuation:STEP[:INCRement]?	Query mechanical attenuator step
[;SENSe]:POWer[:RF]:ATTenuation?	Query mechanical attenuator
[;SENSe]:POWer[:RF]:EATTenuation <rel_ampl>	Set attenuation amount of electronic attenuator
[;SENSe]:POWer[:RF]:EATTenuation:STATe OFF   ON   0   1	Set electronic attenuator ON/OFF
[;SENSe]:POWer[:RF]:EATTenuation:STATe?	Query electronic attenuator ON/OFF
[;SENSe]:POWer[:RF]:EATTenuation?	Query attenuation amount of electronic attenuator
[;SENSe]:POWer[:RF]:GAIN[:STATe] OFF ON 0 1	Set preamplifier
[;SENSe]:POWer[:RF]:GAIN[:STATe]?	Query preamplifier
[;SENSe]:POWer[:RF]:MIXer:RANGe[:UPPer] <real>	Set maximum mixing level
[;SENSe]:POWer[:RF]:MIXer:RANGe[:UPPer]?	Query maximum mixing level
[;SENSe]:RADio:STANdard:DEVIce BTS MS	Set wireless devices
[;SENSe]:RADio:STANdard:DEVIce?	Query wireless devices
[;SENSe]:RADio:STANdard[:SELEct] NONE S95a JST008 S95c C2000 W3GPP NADC PDC TETRa TDS  WL802DOT11A WL802DOT11B WL802DOT11G WL11N20M WL11N 40M WL11AC20M WL11AC40M WL11AC80M WL11AC160M WL11AC 80M80M  WL11AX20M WL11AX40M WL11AX80M WL11AX160M  LTEB1M4 LTEB3M LTEB5M LTEB10M LTEB15M LTEB20M  NR5GFR1B5M NR5GFR1B10M NR5GFR1B15M NR5GFR1B20M NR5G FR1B25M NR5GFR1B30M NR5GFR1B40M NR5GFR1B50M NR5GFR1 B60M NR5GFR1B70M NR5GFR1B80M NR5GFR1B90M NR5GFR1B10 0M  NR5GFR2B50M NR5GFR2B100M NR5GFR2B200M NR5GFR2B400M	Set wireless standards
[;SENSe]:RADio:STANdard[:SELEct]?	Query wireless standards

**Table 5 Zoom table of OBW SCPI commands**

Command	Function
:CALCulate:OBWwidth:LIMit:FBLimit <value>	Set limit bandwidth value

:CALCulate:OBWidth:LIMit:FBLimit?	Query limit bandwidth value
:CALCulate:OBWidth:LIMit[:TEST] ON OFF 1 0	Set the limit test ON/OFF
:CALCulate:OBWidth:LIMit[:TEST]?	Query limit test ON/OFF
:CALCulate:OBWidth:MARKer:AOff	Mkr All Off
:CALCulate:OBWidth:MARKer:COUple[:STATe] ON OFF 1 0	Set Marker Association ON/OFF
:CALCulate:OBWidth:MARKer:COUple[:STATe]?	Query Marker Association ON/OFF
:CALCulate:OBWidth:MARKer:PEAK:EXCursion <value>	Set peak accuracy
:CALCulate:OBWidth:MARKer:PEAK:EXCursion?	Query peak accuracy
:CALCulate:OBWidth:MARKer:PEAK:EXCursion:STATe ON OFF 1 0	Set peak accuracy ON/OFF
:CALCulate:OBWidth:MARKer:PEAK:EXCursion:STATe?	Query peak accuracy ON/OFF
:CALCulate:OBWidth:MARKer:PEAK:SEARch:MODE MAXimum PARameter	Set peak search mode
:CALCulate:OBWidth:MARKer:PEAK:SEARch:MODE?	Query peak search mode
:CALCulate:OBWidth:MARKer:PEAK:THReshold <value>	Set peak threshold
:CALCulate:OBWidth:MARKer:PEAK:THReshold?	Query peak threshold
:CALCulate:OBWidth:MARKer:PEAK:THReshold:STATe ON OFF 1 0	Set peak threshold ON/OFF
:CALCulate:OBWidth:MARKer:PEAK:THReshold:STATe?	Query peak threshold ON/OFF
:CALCulate:OBWidth:MARKer:TABLE[:STATe] ON OFF 1 0	Set marker report ON/OFF
:CALCulate:OBWidth:MARKer:TABLE[:STATe]?	Query marker report ON/OFF
:CALCulate:OBWidth:MARKer[1] 2--12:CPSearch[:STATe] ON OFF 1 0	Set the continuous search ON/OFF
:CALCulate:OBWidth:MARKer[1] 2--12:CPSearch[:STATe]?	Query the continuous search ON/OFF
:CALCulate:OBWidth:MARKer[1] 2--12:LINEs[:STATe] ON OFF 1 0	Set marker line display ON/OFF
:CALCulate:OBWidth:MARKer[1] 2--12:LINEs[:STATe]?	Query marker line display ON/OFF
:CALCulate:OBWidth:MARKer[1] 2--12:MAXimum	Peak Search
:CALCulate:OBWidth:MARKer[1] 2--12:MAXimum:LEFT	Left peak search
:CALCulate:OBWidth:MARKer[1] 2--12:MAXimum:NEXT	Sub-peak search
:CALCulate:OBWidth:MARKer[1] 2--12:MAXimum:RIGHT	Right peak search
:CALCulate:OBWidth:MARKer[1] 2--12:MINimum	Minimum Search
:CALCulate:OBWidth:MARKer[1] 2--12:MODE POSition DELTA FIXed OFF	Set the type for the marker
:CALCulate:OBWidth:MARKer[1] 2--12:MODE?	Query the type for the marker
:CALCulate:OBWidth:MARKer[1] 2--12:REFerence <value>	Set reference marker
:CALCulate:OBWidth:MARKer[1] 2--12:REFerence?	Query reference marker

## Annex B Zoom table of SCPI commands

:CALCulate:OBWidth:MARKer[1]2--12:STATe ON OFF 1 0	Set marker status
:CALCulate:OBWidth:MARKer[1]2--12:STATe?	Query marker state
:CALCulate:OBWidth:MARKer[1]2--12:X <value>	Set the marker X value
:CALCulate:OBWidth:MARKer[1]2--12:X?	Query the marker X value
:CALCulate:OBWidth:MARKer[1]2--12:X:POSition <value>	Set marker X- position
:CALCulate:OBWidth:MARKer[1]2--12:X:POSition?	Query marker X- position
:CALCulate:OBWidth:MARKer[1]2--12:Y <value>	Set marker Y value
:CALCulate:OBWidth:MARKer[1]2--12:Y?	Query the value of marker X.
:CONFigure:OBWidth	Enter occupied bandwidth function
:DISPlay:OBWidth:WINDow[1]:TRACe[1]:Y[:SCALe]:PDIVision <value>	Set scale/division
:DISPlay:OBWidth:WINDow[1]:TRACe[1]:Y[:SCALe]:PDIVision?	Query scale/division
:DISPlay:OBWidth:WINDow[1]:TRACe[1]:Y[:SCALe]:RLEVel <value>	Set reference level
:DISPlay:OBWidth:WINDow[1]:TRACe[1]:Y[:SCALe]:RLEVel?	Query reference level
:DISPlay:OBWidth:WINDow[1]:TRACe[1]:Y[:SCALe]:RLEVel:OFFSet <value>	Set reference level offset
:DISPlay:OBWidth:WINDow[1]:TRACe[1]:Y[:SCALe]:RLEVel:OFFSet?	Query reference level offset
:DISPlay[:WINDow[1]]:TRACe:X:FLINe[1]2--6 <value>	Set frequency display line
:DISPlay[:WINDow[1]]:TRACe:X:FLINe[1]2--6?	Query frequency display line
:DISPlay[:WINDow[1]]:TRACe:X:FLINe[1]2--6:STATe ON OFF 1 0	Set frequency display line ON/OFF
:DISPlay[:WINDow[1]]:TRACe:X:FLINe[1]2--6:STATe?	Query frequency display line ON/OFF
:DISPlay[:WINDow[1]]:TRACe:Y:DLINe[1]2--6 <value>	Set amplitude display line
:DISPlay[:WINDow[1]]:TRACe:Y:DLINe[1]2--6?	Query amplitude display line
:DISPlay[:WINDow[1]]:TRACe:Y:DLINe[1]2--6:STATe ON OFF 1 0	Set amplitude display line ON/OFF
:DISPlay[:WINDow[1]]:TRACe:Y:DLINe[1]2--6:STATe?	Query amplitude display line ON/OFF
:FETCh:OBWidth:FERRor?	Query frequency error results
:FETCh:OBWidth:OBWidth?	Query OBW result
:FETCh:OBWidth:XDB?	Query XDB bandwidth results
:FETCh:OBWidth[1]2--4?	Query measurement results
:INITiate:CONTInuous ON OFF 1 0	Set sweep mode
:INITiate:CONTInuous?	Query sweep mode
:INITiate:REStArt	Restart
:INITiate[:IMMEdiate]	Refresh now
:MEASure:OBWidth:FERRor?	Query frequency error results

## Annex B Zoom table of SCPI commands

:MEASure:OBWidth:OBWidth?	Query OBW result
:MEASure:OBWidth:XDB?	Query XDB bandwidth results
:MEASure:OBWidth[1]2--4?	Query measurement results
:READ:OBWidth:FERRor?	Query frequency error results
:READ:OBWidth:OBWidth?	Query OBW result
:READ:OBWidth:XDB?	Query XDB bandwidth results
:READ:OBWidth[1]2--4?	Query measurement results
:TRACe:OBWidth:DISPlay[:STATe] ON OFF 1 0	Set trace display ON/OFF
:TRACe:OBWidth:DISPlay[:STATe]?	Query trace display ON/OFF
:TRAC:OBWidth:TYPE WRITe AVERAge MAXHold MINHold	Set trace type
:TRAC:OBWidth:TYPE?	Query trace type
:TRAC:OBWidth:UPDate[:STATe] ON OFF 1 0	Set refresh ON/OFF
:TRAC:OBWidth:UPDate[:STATe]?	Query refresh ON/OFF
:TRIGger[:SEQuence]:HOLDoff <time>	Set trigger OFF time
:TRIGger[:SEQuence]:HOLDoff?	Query trigger block time
:TRIGger[:SEQuence]:HOLDoff:STATe OFF ON 0 1	Set trigger block ON/OFF
:TRIGger[:SEQuence]:HOLDoff:STATe?	Query trigger block ON/OFF
:TRIGger[:SEQuence]:EXTernal[1]2 3:DELay <time>	Set trigger delay ON/OFF of External Trigger 1, External Trigger 2, and External Trigger 3
:TRIGger[:SEQuence]:EXTernal[1]2 3:DELay?	Query trigger delay of External Trigger 1, External Trigger 2, and External Trigger 3
:TRIGger[:SEQuence]:EXTernal[1]2 3:DELay:STATe OFF ON 0 1	Set trigger delay ON/OFF of External Trigger 1, External Trigger 2, and External Trigger 3
:TRIGger[:SEQuence]:EXTernal[1]2 3:DELay:STATe?	Query trigger delay ON/OFF of External Trigger 1, External Trigger 2, and External Trigger 3
:TRIGger[:SEQuence]:EXTernal[1]2:LEVel <level>	Set trigger level of External Trigger 1 or External Trigger 2
:TRIGger[:SEQuence]:EXTernal[1]2:LEVel?	Query trigger level of External Trigger 1 or External Trigger 2
:TRIGger[:SEQuence]:EXTernal[1]2 3:SLOPe POSitive NEGative	Set the Trigger Slope of External Trigger 1, External Trigger 2, and External Trigger 3
:TRIGger[:SEQuence]:EXTernal[1]2 3:SLOPe?	Query the Trigger Slope of External Trigger 1, External Trigger 2, and External Trigger 3
:TRIGger[:SEQuence]:FRAMe:DELay <time>	Set Time Trigger delay
:TRIGger[:SEQuence]:FRAMe:DELay?	Query Time Trigger delay
:TRIGger[:SEQuence]:FRAMe:DELay:STATe OFF ON 0 1	Set Trigger Delay ON/OFF of Trigger Timer

**Annex B Zoom table of SCPI commands**

:TRIGger[:SEquence]:FRAME:DElay:STATe?	Query Trigger Delay ON/OFF of Trigger Timer
:TRIGger[:SEquence]:FRAME:OFFSet <time>	Set Time Trigger Offset
:TRIGger[:SEquence]:FRAME:OFFSet?	Query Time Trigger Offset
:TRIGger[:SEquence]:FRAME:PERiod <time>	Set Time Trigger Cycle
:TRIGger[:SEquence]:FRAME:PERiod?	Query Time Trigger Cycle
:TRIGger[:SEquence]:FRAME:SYNC EXTernal1 EXTernal2 RFBurst OFF	Sync Source Selection
:TRIGger[:SEquence]:FRAME:SYNC?	Query Synchronization Source Selection
:TRIGger[:SEquence]:FRAME:SYNC:HOLDoff <time>	Set synchronization source blocking
:TRIGger[:SEquence]:FRAME:SYNC:HOLDoff?	Query synchronization source blocking
:TRIGger[:SEquence]:LINE:DElay <time>	Set power trigger delay
:TRIGger[:SEquence]:LINE:DElay?	Query power trigger delay
:TRIGger[:SEquence]:LINE:DElay:STATe OFF ON 0 1	Set power trigger delay ON/OFF
:TRIGger[:SEquence]:LINE:DElay:STATe?	Query power trigger delay ON/OFF
:TRIGger[:SEquence]:LINE:SLOPe POSitive NEGative	Set Power Trigger Slope
:TRIGger[:SEquence]:LINE:SLOPe?	Query Power Trigger Slope
:TRIGger[:SEquence]:RFBurst:DElay <time>	Set trigger delay of burst signal
:TRIGger[:SEquence]:RFBurst:DElay?	Query trigger delay of burst signal
:TRIGger[:SEquence]:RFBurst:DElay:STATe OFF ON 0 1	Set trigger delay ON/OFF of burst signal
:TRIGger[:SEquence]:RFBurst:DElay:STATe?	Query trigger delay ON/OFF of burst signal
:TRIGger[:SEquence]:RFBurst:LEVel:ABSolute <ampl>	Set burst signal trigger level
:TRIGger[:SEquence]:RFBurst:LEVel:ABSolute?	Query burst signal trigger level
:TRIGger[:SEquence]:RFBurst:SLOPe POSitive NEGative	Set Trigger Slope of Burst Signal Trigger
:TRIGger[:SEquence]:RFBurst:SLOPe?	Query Trigger Slope of Burst Signal Trigger
:TRIGger[:SEquence]:SOURce EXTernal1 EXTernal2 EXTernal3 IMMediate LINE FRAME RFBurst VIDe o	Trigger Mode Selection
:TRIGger[:SEquence]:SOURce?	Query Trigger Mode Selection
:TRIGger[:SEquence]:VIDeo:DElay <time>	Set video trigger delay
:TRIGger[:SEquence]:VIDeo:DElay?	Query video trigger delay
:TRIGger[:SEquence]:VIDeo:DElay:STATe OFF ON 0 1	Set video trigger delay
:TRIGger[:SEquence]:VIDeo:DElay:STATe?	Query video trigger delay
:TRIGger[:SEquence]:VIDeo:LEVel <ampl>	Set video trigger level
:TRIGger[:SEquence]:VIDeo:LEVel?	Query video trigger level

## Annex B Zoom table of SCPI commands

:TRIGger[:SEquence]:VIdeo:SLOPe POSitive NEGative	Set Video Trigger Slope
:TRIGger[:SEquence]:VIdeo:SLOPe?	Query Video Trigger Slope
:UNIT:OBWidth:POWer DBM DBM DBMV DBMA V W A DBUV DBUA	Set vertical axis scale
:UNIT:OBWidth:POWer?	Query vertical axis scale
[:SENSe]:FREQuency:CENTer <value>	Set center frequency
[:SENSe]:FREQuency:CENTer?	Query center frequency
[:SENSe]:FREQuency:CENTer:STEP:AUTO ON OFF 1 0	Set the frequency step ON/OFF
[:SENSe]:FREQuency:CENTer:STEP:AUTO?	Query frequency step ON/OFF
[:SENSe]:FREQuency:CENTer:STEP[:INCRement] <value>	Set the frequency step
[:SENSe]:FREQuency:CENTer:STEP[:INCRement]?	Query frequency step
[:SENSe]:FREQuency:OFFSet <value>	Set frequency offset
[:SENSe]:FREQuency:OFFSet?	Query frequency offset
[:SENSe]:OBWidth:ADC:DITHer:AUTO[:STATe] ON OFF 1 0	Set ADC Dither ON/OFF
[:SENSe]:OBWidth:ADC:DITHer:AUTO[:STATe]?	Query ADC Dither ON/OFF
[:SENSe]:OBWidth:ADC:DITHer[:STATe] ON OFF HIGH	Set ADC Dither
[:SENSe]:OBWidth:ADC:DITHer[:STATe]?	Query ADC Dither
[:SENSe]:OBWidth:ADJust:LEVel	Auto Scaling
[:SENSe]:OBWidth:AVERage:COUnT <value>	Set average times
[:SENSe]:OBWidth:AVERage:COUnT?	Query average times
[:SENSe]:OBWidth:AVERage:TCONtrol EXPOntial  REPeat 1 0	Set the average mode
[:SENSe]:OBWidth:AVERage:TCONtrol?	Query average mode
[:SENSe]:OBWidth:AVERage[:STATe] ON OFF 1 0	SetAvgOn
[:SENSe]:OBWidth:AVERage[:STATe]?	QueryAvgOn
[:SENSe]:OBWidth:BANDwidth BWIDTH:SHAPE GAUSSian FLATtop	Set the filter type
[:SENSe]:OBWidth:BANDwidth BWIDTH:SHAPE?	Query filter type
[:SENSe]:OBWidth:BANDwidth BWIDTH:TYPE DB3 DB6	Set filter bandwidth
[:SENSe]:OBWidth:BANDwidth BWIDTH:TYPE?	Query filter bandwidth
[:SENSe]:OBWidth:BANDwidth BWIDTH:VIdeo <value>	Set VBW
[:SENSe]:OBWidth:BANDwidth BWIDTH:VIdeo?	QueryVBW
[:SENSe]:OBWidth:BANDwidth BWIDTH:VIdeo:AUTO ON OFF 1 0	Set VBW ON/OFF
[:SENSe]:OBWidth:BANDwidth BWIDTH:VIdeo:AUTO?	Query VBW ON/OFF
[:SENSe]:OBWidth:BANDwidth BWIDTH[:RESolution] <value>	Set RBW

**Annex B Zoom table of SCPI commands**

[:SENSe]:OBWidth:BAWidTh BWIDTh[:RESolution]?	Query RBW
[:SENSe]:OBWidth:BAWidTh BWIDTh[:RESolution]:AUTO ON OFF 1 0	Set RBW ON/OFF
[:SENSe]:OBWidth:BAWidTh BWIDTh[:RESolution]:AUTO?	Query RBW ON/OFF
[:SENSe]:OBWidth:DETEctor:AUTO ON OFF 1 0	Set detection mode ON/OFF
[:SENSe]:OBWidth:DETEctor:AUTO?	Query detection mode ON/OFF
[:SENSe]:OBWidth:DETEctor[:FUNCTION] NORMal AVERAge POSitive SAMPle NEGative RMS SCALar	Set detection mode
[:SENSe]:OBWidth:DETEctor[:FUNCTION]?	Query detector mode
[:SENSe]:OBWidth:FREQUency:SPAN <value>	Set span
[:SENSe]:OBWidth:FREQUency:SPAN?	Query span
[:SENSe]:OBWidth:FREQUency:SPAN:FULL	Set full span
[:SENSe]:OBWidth:FREQUency:SPAN:PREVious	Set Previous Span
[:SENSe]:OBWidth:PERCent <value>	Set power percentage
[:SENSe]:OBWidth:PERCent?	Query power percentage
[:SENSe]:OBWidth:SLIMits:LEFT <value>	Set search limit start
[:SENSe]:OBWidth:SLIMits:LEFT?	Query search limit start
[:SENSe]:OBWidth:SLIMits:RIGHT <value>	Set search limit stop
[:SENSe]:OBWidth:SLIMits:RIGHT?	Query search limit stop
[:SENSe]:OBWidth:SLIMits[:STATE] ON OFF 1 0	Set search limit ON/OFF
[:SENSe]:OBWidth:SLIMits[:STATE]?	Query search limit ON/OFF
[:SENSe]:OBWidth:SWEep:FFT:WIDTh <value>	Set FFT width
[:SENSe]:OBWidth:SWEep:FFT:WIDTh?	Query FFT width
[:SENSe]:OBWidth:SWEep:FFT:WIDTh:AUTO ON OFF 1 0	Set FFT width ON/OFF
[:SENSe]:OBWidth:SWEep:FFT:WIDTh:AUTO?	Query FFT width ON/OFF
[:SENSe]:OBWidth:SWEep:POINts <value>	Set number of sweep points
[:SENSe]:OBWidth:SWEep:POINts?	Query number of sweep points
[:SENSe]:OBWidth:SWEep:TIME <value>	Set SwpTime
[:SENSe]:OBWidth:SWEep:TIME?	QuerySwpTime
[:SENSe]:OBWidth:SWEep:TIME:AUTO ON OFF 1 0	Set sweep time ON/OFF
[:SENSe]:OBWidth:SWEep:TIME:AUTO?	Query sweep time ON/OFF
[:SENSe]:OBWidth:SWEep:TIME:AUTO:RULEs NORMal ACCuracy SRESPonse	Set sweep time AUTO rule
[:SENSe]:OBWidth:SWEep:TIME:AUTO:RULEs?	Query sweep time AUTO rule

## Annex B Zoom table of SCPI commands

[:SENSe]:OBWidth:SWEEP:TYPE FFT SWEEP	SetSwpType
[:SENSe]:OBWidth:SWEEP:TYPE?	QuerySwpType
[:SENSe]:OBWidth:SWEEP:TYPE:AUTO ON OFF 1 0	Set sweep type ON/OFF
[:SENSe]:OBWidth:SWEEP:TYPE:AUTO?	Query sweep type ON/OFF
[:SENSe]:OBWidth:SWEEP:TYPE:AUTO:RULES SPEED DRANGE	Set sweep type Auto rule
[:SENSe]:OBWidth:SWEEP:TYPE:AUTO:RULES?	Query sweep type Auto rule
[:SENSe]:OBWidth:SWEEP:TYPE:AUTO:RULES:AUTO[:STATE] ON OFF 1 0	Set sweep type rule ON/OFF
[:SENSe]:OBWidth:SWEEP:TYPE:AUTO:RULES:AUTO[:STATE]?	Query sweep type rule ON/OFF
[:SENSe]:OBWidth:XDB <value>	Set XDB
[:SENSe]:OBWidth:XDB?	Query XDB
[:SENSe]:POWER[:RF]:ATTENUATION <value>	Set attenuator
[:SENSe]:POWER[:RF]:ATTENUATION?	Query attenuator
[:SENSe]:POWER[:RF]:ATTENUATION:AUTO ON OFF 1 0	Set attenuator ON/OFF
[:SENSe]:POWER[:RF]:ATTENUATION:AUTO?	Query attenuator ON/OFF
[:SENSe]:POWER[:RF]:ATTENUATION:STEP[:INCREMENT]	Set attenuator step
[:SENSe]:POWER[:RF]:ATTENUATION:STEP[:INCREMENT]?	Query attenuator step
[:SENSe]:POWER[:RF]:EATTENUATION <value>	Set electronic attenuator
[:SENSe]:POWER[:RF]:EATTENUATION?	Query electronic attenuator
[:SENSe]:POWER[:RF]:EATTENUATION:STATE ON OFF 1 0	Set electronic attenuator ON/OFF
[:SENSe]:POWER[:RF]:EATTENUATION:STATE?	Query electronic attenuator ON/OFF
[:SENSe]:POWER[:RF]:GAIN[:STATE] ON OFF 1 0	Set gain ON/OFF
[:SENSe]:POWER[:RF]:GAIN[:STATE]?	Query gain ON/OFF
[:SENSe]:POWER[:RF]:MIXER:RANGE[:UPPER] <value>	Set the maximum mixer level
[:SENSe]:POWER[:RF]:MIXER:RANGE[:UPPER]?	Query maximum mixer level
[:SENSe]:POWER[:RF]:MIXER:RULES NORMAL TO COMPRESSION	Set maximum mixer level rule
[:SENSe]:POWER[:RF]:MIXER:RULES?	Query maximum mixer level rule
[:SENSe]:RADIO:STANDARD:DEVICE BTS MS	Set wireless devices type
[:SENSe]:RADIO:STANDARD:DEVICE?	Query wireless devices type

**Annex B Zoom table of SCPI commands**

[:SENSe]:RADio:STANdard[:SElect] NONE IS95a JST008 IS95c C2000 W3GPP NADC PDC TETRa TDS WL802DOT11A WL802DOT11B WL802DOT11G WL11N20M WL11N40M WL11AC20M WL11AC40M WL11AC80M WL11AC160M WL11AC80M80M WL11AX20M WL11AX40M WL11AX80M WL11AX160M LTEB1M4 LTEB3M LTEB5M LTEB10M LTEB15M LTEB20M NR5GFR1B5M NR5GFR1B10M NR5GFR1B15M NR5GFR1B20M NR5GFR1B25M NR5GFR1B30M NR5GFR1B40M NR5GFR1B50M NR5GFR1B60M NR5GFR1B70M NR5GFR1B80M NR5GFR1B90M NR5GFR1B100M NR5GFR2B50M NR5GFR2B100M NR5GFR2B200M NR5GFR2B400M	Set wireless standards
[:SENSe]:RADio:STANdard[:SElect]?	Query wireless standards

**Table 6 Zoom table of power statistics SCPI commands**

Command	Function
[:SENSe]:FREQuency:CENTer <frequency>	Set center frequency
[:SENSe]:FREQuency:CENTer?	Query center frequency
[:SENSe]:FREQuency:OFFSet <freq>	Set frequency offset
[:SENSe]:FREQuency:OFFSet?	Query frequency offset
[:SENSe]:FREQuency:CENTer:STEP[:INCRement] <freq>	Set the frequency step
[:SENSe]:FREQuency:CENTer:STEP[:INCRement]?	Query frequency step
[:SENSe]:FREQuency:CENTer:STEP:AUTO OFF ON 0 1	Set whether frequency step is Auto
[:SENSe]:FREQuency:CENTer:STEP:AUTO?	Query whether frequency step is Auto
[:SENSe]:POWer[:RF]:ATTenuation <rel_power>	Set mechanical attenuator
[:SENSe]:POWer[:RF]:ATTenuation?	Query mechanical attenuator
[:SENSe]:POWer[:RF]:ATTenuation:AUTO OFF ON 0 1	Set whether mechanical attenuator is automatic
[:SENSe]:POWer[:RF]:ATTenuation:AUTO?	Query whether mechanical attenuator is automatic
[:SENSe]:POWer[:RF]:ATTenuation:STEP[:INCRement] 10dB 2dB	Set mechanical attenuator step
[:SENSe]:POWer[:RF]:ATTenuation:STEP[:INCRement]?	Query mechanical attenuator step
[:SENSe]:POWer[:RF]:MIXer:RANGe[:UPPer] <power>	Set the maximum mixer level
[:SENSe]:POWer[:RF]:MIXer:RANGe[:UPPer]?	Query maximum mixer level
[:SENSe]:POWer[:RF]:GAIN[:STATe] OFF ON 0 1	Set preamplifier ON/OFF
[:SENSe]:POWer[:RF]:GAIN[:STATe]?	Query preamplifier ON/OFF
[:SENSe]:POWer[:RF]:EATTenuation <rel_ampl>	Set electronic attenuator
[:SENSe]:POWer[:RF]:EATTenuation?	Query electronic attenuator
:PStatistic:BANDwidth <bandwidth>	Set measurement bandwidth
:PStatistic:BANDwidth?	Query measurement bandwidth

## Annex B Zoom table of SCPI commands

:DISPlay:PStatistic:RTRace OFF ON 0 1	Set reference trace display
:DISPlay:PStatistic:RTRace?	Query reference trace display
:DISPlay:PStatistic:GAUSSian OFF ON 0 1	Set the display of Gaussian curves
:DISPlay:PStatistic:GAUSSian?	Query the display status of Gaussian curve
[:SENSe]:SWEep:EGATe:HOLDoff <time>	Set trigger OFF time
[:SENSe]:SWEep:EGATe:HOLDoff?	Query trigger block time
[:SENSe]:SWEep:EGATe:HOLDoff:AUTO OFF ON 0 1	Set trigger block ON/OFF
[:SENSe]:SWEep:EGATe:HOLDoff:AUTO?	Query trigger block ON/OFF
:TRIGger[:SEQuence]:EXTeRnal[1] 2 3:DElay <time>	Set trigger delay ON/OFF of External Trigger 1, External Trigger 2, and External Trigger 3
:TRIGger[:SEQuence]:EXTeRnal[1] 2 3:DElay?	Query trigger delay of External Trigger 1, External Trigger 2, and External Trigger 3
:TRIGger[:SEQuence]:EXTeRnal[1] 2 3:DElay:STATe OFF ON 0 1	Set trigger delay ON/OFF of External Trigger 1, External Trigger 2, and External Trigger 3
:TRIGger[:SEQuence]:EXTeRnal[1] 2 3:DElay:STATe?	Query trigger delay ON/OFF of External Trigger 1, External Trigger 2, and External Trigger 3
:TRIGger[:SEQuence]:EXTeRnal[1] 2:LEvel <level>	Set trigger level of External Trigger 1 or External Trigger 2
:TRIGger[:SEQuence]:EXTeRnal[1] 2:LEvel?	Query trigger level of External Trigger 1 or External Trigger 2
:TRIGger[:SEQuence]:EXTeRnal[1] 2 3:SLOPe POSitive NEGative	Set the Trigger Slope of External Trigger 1, External Trigger 2, and External Trigger 3
:TRIGger[:SEQuence]:EXTeRnal[1] 2 3:SLOPe?	Query the Trigger Slope of External Trigger 1, External Trigger 2, and External Trigger 3
:TRIGger[:SEQuence]:FRAMe:DElay <time>	Set Time Trigger delay
:TRIGger[:SEQuence]:FRAMe:DElay?	Query Time Trigger delay
:TRIGger[:SEQuence]:FRAMe:DElay:STATe OFF ON 0 1	Set Trigger Delay ON/OFF of Trigger Timer
:TRIGger[:SEQuence]:FRAMe:DElay:STATe?	Query Trigger Delay ON/OFF of Trigger Timer
:TRIGger[:SEQuence]:FRAMe:OFFSet <time>	Set Time Trigger Offset
:TRIGger[:SEQuence]:FRAMe:OFFSet?	Query Time Trigger Offset
:TRIGger[:SEQuence]:FRAMe:PERiod <time>	Set Time Trigger Cycle
:TRIGger[:SEQuence]:FRAMe:PERiod?	Query Time Trigger Cycle
:TRIGger[:SEQuence]:FRAMe:SYNC EXTeRnal1 EXTeRnal2 EXTeRnal3 RFBUrst OFF	Sync Source Selection
:TRIGger[:SEQuence]:FRAMe:SYNC?	Query Synchronization Source Selection
:TRIGger[:SEQuence]:FRAMe:SYNC:HOLDoff <time>	Set synchronization source blocking
:TRIGger[:SEQuence]:FRAMe:SYNC:HOLDoff?	Query synchronization source blocking

**Annex B Zoom table of SCPI commands**

:TRIGger[:SEquence]:LINE:DElay <time>	Set power trigger delay
:TRIGger[:SEquence]:LINE:DElay?	Query power trigger delay
:TRIGger[:SEquence]:LINE:DElay:STATe OFF ON 0 1	Set power trigger delay ON/OFF
:TRIGger[:SEquence]:LINE:DElay:STATe?	Query power trigger delay ON/OFF
:TRIGger[:SEquence]:LINE:SLOPe POSitive NEGative	Set Power Trigger Slope
:TRIGger[:SEquence]:LINE:SLOPe?	Query Power Trigger Slope
:TRIGger[:SEquence]:RFBurst:DElay <time>	Set trigger delay of burst signal
:TRIGger[:SEquence]:RFBurst:DElay?	Query trigger delay of burst signal
:TRIGger[:SEquence]:RFBurst:DElay:STATe OFF ON 0 1	Set trigger delay ON/OFF of burst signal
:TRIGger[:SEquence]:RFBurst:DElay:STATe?	Query trigger delay ON/OFF of burst signal
:TRIGger[:SEquence]:RFBurst:LEVel:ABSolute <ampl>	Set burst signal trigger level
:TRIGger[:SEquence]:RFBurst:LEVel:ABSolute?	Query burst signal trigger level
:TRIGger[:SEquence]:RFBurst:SLOPe POSitive NEGative	Set Trigger Slope of Burst Signal Trigger
:TRIGger[:SEquence]:RFBurst:SLOPe?	Query Trigger Slope of Burst Signal Trigger
:TRIGger[:SEquence]:SOURce EXTernal1 EXTernal2 EXTernal3 IMMediate LINE FRAME RFBurst VIDeo	Trigger Mode Selection
:TRIGger[:SEquence]:SOURce?	Query Trigger Mode Selection
:TRIGger[:SEquence]:VIDeo:DElay <time>	Set video trigger delay
:TRIGger[:SEquence]:VIDeo:DElay?	Query video trigger delay
:TRIGger[:SEquence]:VIDeo:DElay:STATe OFF ON 0 1	Set video trigger delay ON/OFF
:TRIGger[:SEquence]:VIDeo:DElay:STATe?	Query video trigger delay ON/OFF
:TRIGger[:SEquence]:VIDeo:LEVel <ampl>	Set video trigger level
:TRIGger[:SEquence]:VIDeo:LEVel?	Query video trigger level
:TRIGger[:SEquence]:VIDeo:SLOPe POSitive NEGative	Set Video Trigger Slope
:TRIGger[:SEquence]:VIDeo:SLOPe?	Query Video Trigger Slope
[:SENSe]:PSTatic:ADC:DITHer[:STATe] OFF ON 0 1	Set whether to turn on ADC Dither
[:SENSe]:PSTatic:ADC:DITHer[:STATe]?	Query whether ADC Dither is turned on
[:SENSe]:PSTatic:ADC:DITHer:AUTO[:STATe] OFF ON 0 1	Set whether to turn on automatic ADC Dither
[:SENSe]:PSTatic:ADC:DITHer:AUTO[:STATe]?	Query whether automatic ADC Dither is turned on
[:SENSe]:PSTatic:COUNts <integer>	Set accumulated number of data sampling points
[:SENSe]:PSTatic:COUNts?	Query accumulated number of data sampling points
[:SENSe]:PSTatic:SWEep:CYCLes <integer>	Set the number of loop measurements corresponding to cumulative points

## Annex B Zoom table of SCPI commands

[:SENSe]:PStatistic:SWEEp:CYCLes?	Query the number of loop measurements corresponding to cumulative points
[:SENSe]:PStatistic:SWEEp:TIME <time>	Set measurement time
[:SENSe]:PStatistic:SWEEp:TIME?	Query measurement time
:CALCulate:MARKer[1] 2--12:MODE Normal DELTA FIXed OFF	Set marker mode
:CALCulate:MARKer[1] 2--12:MODE?	Query marker mode
:CALCulate:PStatistic:MARKer[1] 2--12:REfERENCE <integer>	Set reference marker
:CALCulate:PStatistic:MARKer[1] 2--12:REfERENCE?	Query reference marker
:CALCulate:PStatistic:MARKer:AOff	Mkr All Off

Table 7 Zoom table burst power SCPI commands

Command	Function
:CALCulate:TXPower:BURSt:WIDTh <value>	Set burst width
:CALCulate:TXPower:BURSt:WIDTh?	Query burst width
:CALCulate:TXPower:MARKer:AOff	Mkr All Off
:CALCulate:TXPower:MARKer:COUple[:STATe] ON OFF 1 0	Set Marker Association ON/OFF
:CALCulate:TXPower:MARKer:COUple[:STATe]?	Query Marker Association ON/OFF
:CALCulate:TXPower:MARKer:PEAK:EXCurSION <value>	Set peak accuracy
:CALCulate:TXPower:MARKer:PEAK:EXCurSION?	Query peak accuracy
:CALCulate:TXPower:MARKer:PEAK:EXCurSION:STATe ON OFF 1 0	Set peak accuracy ON/OFF
:CALCulate:TXPower:MARKer:PEAK:EXCurSION:STATe?	Query peak accuracy ON/OFF
:CALCulate:TXPower:MARKer:PEAK:SEARCh:MODE MAXimum PARAmeter	Set peak search mode
:CALCulate:TXPower:MARKer:PEAK:SEARCh:MODE?	Query peak search mode
:CALCulate:TXPower:MARKer:PEAK:THReshold <value>	Set peak threshold
:CALCulate:TXPower:MARKer:PEAK:THReshold?	Query peak threshold
:CALCulate:TXPower:MARKer:PEAK:THReshold:STATe ON OFF 1 0	Set peak threshold ON/OFF
:CALCulate:TXPower:MARKer:PEAK:THReshold:STATe?	Query peak threshold ON/OFF
:CALCulate:TXPower:MARKer:TABLE[:STATe] ON OFF 1 0	Set marker report ON/OFF
:CALCulate:TXPower:MARKer:TABLE[:STATe]?	Query marker report ON/OFF
:CALCulate:TXPower:MARKer[1] 2--12:CPSeARch[:STATe] ON OFF 1 0	Set the continuous search ON/OFF
:CALCulate:TXPower:MARKer[1] 2--12:CPSeARch[:STATe]?	Query the continuous search ON/OFF
:CALCulate:TXPower:MARKer[1] 2--12:LINEs[:STATe] ON OFF 1 0	Set marker line display ON/OFF
:CALCulate:TXPower:MARKer[1] 2--12:LINEs[:STATe]?	Query marker line display ON/OFF

**Annex B Zoom table of SCPI commands**

:CALCulate:TXPower:MARKer[1]2--12:MAXimum	Peak Search
:CALCulate:TXPower:MARKer[1]2--12:MAXimum:LEFT	Left peak search
:CALCulate:TXPower:MARKer[1]2--12:MAXimum:NEXT	Sub-peak search
:CALCulate:TXPower:MARKer[1]2--12:MAXimum:RIGHT	Right peak search
:CALCulate:TXPower:MARKer[1]2--12:MINimum	Minimum Search
:CALCulate:TXPower:MARKer[1]2--12:MODE POSITION DELTA FIXed OFF	Set the type for the marker
:CALCulate:TXPower:MARKer[1]2--12:MODE?	Query the type for the marker
:CALCulate:TXPower:MARKer[1]2--12:REFERENCE <value>	Set reference marker
:CALCulate:TXPower:MARKer[1]2--12:REFERENCE?	Query reference marker
:CALCulate:TXPower:MARKer[1]2--12:STATE ON OFF 1 0	Set marker status
:CALCulate:TXPower:MARKer[1]2--12:STATE?	Query marker state
:CALCulate:TXPower:MARKer[1]2--12:X <value>	Set the marker X value
:CALCulate:TXPower:MARKer[1]2--12:X?	Query the marker X value
:CALCulate:TXPower:MARKer[1]2--12:X:POSITION <value>	Set marker X- position
:CALCulate:TXPower:MARKer[1]2--12:X:POSITION?	Query marker X- position
:CALCulate:TXPower:MARKer[1]2--12:Y <value>	Set marker Y value
:CALCulate:TXPower:MARKer[1]2--12:Y?	Query the value of marker X.
:CALCulate:TXPower:THReshold:TYPE ABSolute RELative	Set threshold type
:CALCulate:TXPower:THReshold:TYPE?	Query threshold type
:CONFigure:TXPower	Enter burst power measurement function
:DISPlay:TXPower:WINDow[1]:TRACe[1]:Y[:SCALE]:PDIVision <value>	Set scale/division
:DISPlay:TXPower:WINDow[1]:TRACe[1]:Y[:SCALE]:PDIVision?	Query scale/division
:DISPlay:TXPower:WINDow[1]:TRACe[1]:Y[:SCALE]:RLEVel <value>	Set reference level
:DISPlay:TXPower:WINDow[1]:TRACe[1]:Y[:SCALE]:RLEVel?	Query reference level
:DISPlay:TXPower:WINDow[1]:TRACe[1]:Y[:SCALE]:RLEVel:OFFSet <value>	Set reference level offset
:DISPlay:TXPower:WINDow[1]:TRACe[1]:Y[:SCALE]:RLEVel:OFFSet?	Query reference level offset
:DISPlay:WINDow[1]:TRACe:Y:DLINe[1]2--6 <value>	Set amplitude display line
:DISPlay:WINDow[1]:TRACe:Y:DLINe[1]2--6?	Query amplitude display line
:DISPlay:WINDow[1]:TRACe:Y:DLINe[1]2--6:STATE ON OFF 1 0	Set amplitude display line ON/OFF
:DISPlay:WINDow[1]:TRACe:Y:DLINe[1]2--6:STATE?	Query amplitude display line ON/OFF
:FETCh:TXPower[1]2--4?	Query measurement results
:INITiate:CONTInuous ON OFF 1 0	Set sweep mode

## Annex B Zoom table of SCPI commands

:INITiate:CONTInuous?	Query sweep mode
:INITiate:REStart	Restart
:INITiate[:IMMEDIATE]	Refresh now
:MEASure:TXPower[1]2--4?	Query measurement results
:READ:TXPower[1]2--4?	Query measurement results
:TRACe:TXPower:DISPlay[:STATe] ON OFF 1 0	Set trace display ON/OFF
:TRACe:TXPower:DISPlay[:STATe]?	Query trace display ON/OFF
:TRAC:TXPower:TYPE WRITe AVERAge MAXHold MINHold	Set trace type
:TRAC:TXPower:TYPE?	Query trace type
:TRAC:TXPower:UPDate[:STATe] ON OFF 1 0	Set refresh ON/OFF
:TRAC:TXPower:UPDate[:STATe]?	Query refresh ON/OFF
:TRIGger[:SEQuence]:HOLDoff <time>	Set trigger OFF time
:TRIGger[:SEQuence]:HOLDoff?	Query trigger block time
:TRIGger[:SEQuence]:HOLDoff:STATe OFF ON 0 1	Set trigger block ON/OFF
:TRIGger[:SEQuence]:HOLDoff:STATe?	Query trigger block ON/OFF
:TRIGger[:SEQuence]:EXTeRnal[1]2 3:DELAy <time>	Set trigger delay ON/OFF of External Trigger 1, External Trigger 2, and External Trigger 3
:TRIGger[:SEQuence]:EXTeRnal[1]2 3:DELAy?	Query trigger delay of External Trigger 1, External Trigger 2, and External Trigger 3
:TRIGger[:SEQuence]:EXTeRnal[1]2 3:DELAy:STATe OFF ON 0 1	Set trigger delay ON/OFF of External Trigger 1, External Trigger 2, and External Trigger 3
:TRIGger[:SEQuence]:EXTeRnal[1]2 3:DELAy:STATe?	Query trigger delay ON/OFF of External Trigger 1, External Trigger 2, and External Trigger 3
:TRIGger[:SEQuence]:EXTeRnal[1]2:LEVel <level>	Set trigger level of External Trigger 1 or External Trigger 2
:TRIGger[:SEQuence]:EXTeRnal[1]2:LEVel?	Query trigger level of External Trigger 1 or External Trigger 2
:TRIGger[:SEQuence]:EXTeRnal[1]2 3:SLOPe POSitive NEGative	Set the Trigger Slope of External Trigger 1, External Trigger 2, and External Trigger 3
:TRIGger[:SEQuence]:EXTeRnal[1]2 3:SLOPe?	Query the Trigger Slope of External Trigger 1, External Trigger 2, and External Trigger 3
:TRIGger[:SEQuence]:FRAMe:DELAy <time>	Set Time Trigger delay
:TRIGger[:SEQuence]:FRAMe:DELAy?	Query Time Trigger delay
:TRIGger[:SEQuence]:FRAMe:DELAy:STATe OFF ON 0 1	Set Trigger Delay ON/OFF of Trigger Timer
:TRIGger[:SEQuence]:FRAMe:DELAy:STATe?	Query Trigger Delay ON/OFF of Trigger Timer
:TRIGger[:SEQuence]:FRAMe:OFFSet <time>	Set Time Trigger Offset

**Annex B Zoom table of SCPI commands**

:TRIGger[:SEquence]:FRAME:OFFSet?	Query Time Trigger Offset
:TRIGger[:SEquence]:FRAME:PERiod <time>	Set Time Trigger Cycle
:TRIGger[:SEquence]:FRAME:PERiod?	Query Time Trigger Cycle
:TRIGger[:SEquence]:FRAME:SYNC EXTernal1 EXTernal2 RFBurst OFF	Sync Source Selection
:TRIGger[:SEquence]:FRAME:SYNC?	Query Synchronization Source Selection
:TRIGger[:SEquence]:FRAME:SYNC:HOLDoff <time>	Set synchronization source blocking
:TRIGger[:SEquence]:FRAME:SYNC:HOLDoff?	Query synchronization source blocking
:TRIGger[:SEquence]:LINE:DELay <time>	Set power trigger delay
:TRIGger[:SEquence]:LINE:DELay?	Query power trigger delay
:TRIGger[:SEquence]:LINE:DELay:STATe OFF ON 0 1	Set power trigger delay ON/OFF
:TRIGger[:SEquence]:LINE:DELay:STATe?	Query power trigger delay ON/OFF
:TRIGger[:SEquence]:LINE:SLOPe POSitive NEGative	Set Power Trigger Slope
:TRIGger[:SEquence]:LINE:SLOPe?	Query Power Trigger Slope
:TRIGger[:SEquence]:RFBurst:DELay <time>	Set trigger delay of burst signal
:TRIGger[:SEquence]:RFBurst:DELay?	Query trigger delay of burst signal
:TRIGger[:SEquence]:RFBurst:DELay:STATe OFF ON 0 1	Set trigger delay ON/OFF of burst signal
:TRIGger[:SEquence]:RFBurst:DELay:STATe?	Query trigger delay ON/OFF of burst signal
:TRIGger[:SEquence]:RFBurst:LEVel:ABSolute <ampl>	Set burst signal trigger level
:TRIGger[:SEquence]:RFBurst:LEVel:ABSolute?	Query burst signal trigger level
:TRIGger[:SEquence]:RFBurst:SLOPe POSitive NEGative	Set Trigger Slope of Burst Signal Trigger
:TRIGger[:SEquence]:RFBurst:SLOPe?	Query Trigger Slope of Burst Signal Trigger
:TRIGger[:SEquence]:SOURce EXTernal1 EXTernal2 EXTernal3 IMMediate LINE FRAME RFBurst VIDe o	Trigger Mode Selection
:TRIGger[:SEquence]:SOURce?	Query Trigger Mode Selection
:TRIGger[:SEquence]:VIDeo:DELay <time>	Set video trigger delay
:TRIGger[:SEquence]:VIDeo:DELay?	Query video trigger delay
:TRIGger[:SEquence]:VIDeo:DELay:STATe OFF ON 0 1	Set video trigger delay
:TRIGger[:SEquence]:VIDeo:DELay:STATe?	Query video trigger delay
:TRIGger[:SEquence]:VIDeo:LEVel <ampl>	Set video trigger level
:TRIGger[:SEquence]:VIDeo:LEVel?	Query video trigger level
:TRIGger[:SEquence]:VIDeo:SLOPe POSitive NEGative	Set Video Trigger Slope
:TRIGger[:SEquence]:VIDeo:SLOPe?	Query Video Trigger Slope

## Annex B Zoom table of SCPI commands

:UNIT:TXPower:POWer DBM DBM DBMV DBMA V W A DBUV DBUA	Set vertical axis scale
:UNIT:TXPower:POWer?	Query vertical axis scale
[:SENSe]:FREQuency:CENTer <value>	Set center frequency
[:SENSe]:FREQuency:CENTer?	Query center frequency
[:SENSe]:FREQuency:CENTer:STEP:AUTO ON OFF 1 0	Set the frequency step ON/OFF
[:SENSe]:FREQuency:CENTer:STEP:AUTO?	Query frequency step ON/OFF
[:SENSe]:FREQuency:CENTer:STEP[:INCRement] <value>	Set the frequency step
[:SENSe]:FREQuency:CENTer:STEP[:INCRement]?	Query frequency step
[:SENSe]:FREQuency:OFFSet <value>	Set frequency offset
[:SENSe]:FREQuency:OFFSet?	Query frequency offset
[:SENSe]:TXPower:ADC:DITHer:AUTO[:STATe] ON OFF 1 0	Set ADC Dither ON/OFF
[:SENSe]:TXPower:ADC:DITHer:AUTO[:STATe]?	Query ADC Dither ON/OFF
[:SENSe]:TXPower:ADC:DITHer[:STATe] ON OFF HIGH	Set ADC Dither
[:SENSe]:TXPower:ADC:DITHer[:STATe]?	Query ADC Dither
[:SENSe]:TXPower:ADJust.LEVel	Auto Scaling
[:SENSe]:TXPower:AVERAge:COUnT <value>	Set average times
[:SENSe]:TXPower:AVERAge:COUnT?	Query average times
[:SENSe]:TXPower:AVERAge:TCONtrol EXPonential  REPeat 1 0	Set the average mode
[:SENSe]:TXPower:AVERAge:TCONtrol?	Query average mode
[:SENSe]:TXPower:AVERAge[:STATe] ON OFF 1 0	SetAvgOn
[:SENSe]:TXPower:AVERAge[:STATe]?	QueryAvgOn
[:SENSe]:TXPower:BANDwidth BWiDth:SHAPE GAUSSian FLATtop	Set the filter type
[:SENSe]:TXPower:BANDwidth BWiDth:SHAPE?	Query filter type
[:SENSe]:TXPower:BANDwidth BWiDth:TYPE DB3 DB6	Set filter bandwidth
[:SENSe]:TXPower:BANDwidth BWiDth:TYPE?	Query filter bandwidth
[:SENSe]:TXPower:BANDwidth BWiDth:VIDeo <value>	Set VBW
[:SENSe]:TXPower:BANDwidth BWiDth:VIDeo?	QueryVBW
[:SENSe]:TXPower:BANDwidth BWiDth:VIDeo:AUTO ON OFF 1 0	Set VBW ON/OFF
[:SENSe]:TXPower:BANDwidth BWiDth:VIDeo:AUTO?	Query VBW ON/OFF
[:SENSe]:TXPower:BANDwidth BWiDth[:RESolution] <value>	Set RBW
[:SENSe]:TXPower:BANDwidth BWiDth[:RESolution]?	Query RBW

**Annex B Zoom table of SCPI commands**

[:SENSe]:TXPower:BANDwidth BWIDth[:RESolution]:AUTO ON OFF 1 0	Set RBW ON/OFF
[:SENSe]:TXPower:BANDwidth BWIDth[:RESolution]:AUTO?	Query RBW ON/OFF
[:SENSe]:TXPower:BURSt:AUTO ON OFF 1 0	Set burst width switch
[:SENSe]:TXPower:BURSt:AUTO?	Query burst width switch
[:SENSe]:TXPower:DETEctor:AUTO ON OFF 1 0	Set detection mode ON/OFF
[:SENSe]:TXPower:DETEctor:AUTO?	Query detection mode ON/OFF
[:SENSe]:TXPower:DETEctor[:FUNction] NORMal AVERage POSitive SAMPLe NEGative RMS SCALar	Set detection mode
[:SENSe]:TXPower:DETEctor[:FUNction]?	Query detector mode
[:SENSe]:TXPower:METhod THReshold BWIDth	Set measurement method
[:SENSe]:TXPower:METhod?	Query measurement method
[:SENSe]:TXPower:SWEEp:POINts <value>	Set number of sweep points
[:SENSe]:TXPower:SWEEp:POINts?	Query number of sweep points
[:SENSe]:TXPower:SWEEp:TIME <value>	Set SwpTime
[:SENSe]:TXPower:SWEEp:TIME?	QuerySwpTime
[:SENSe]:TXPower:SWEEp:TIME:AUTO ON OFF 1 0	Set sweep time ON/OFF
[:SENSe]:TXPower:SWEEp:TIME:AUTO?	Query sweep time ON/OFF
[:SENSe]:TXPower:THReshold <value>	Set threshold level
[:SENSe]:TXPower:THReshold?	Query threshold level
[:SENSe]:POWer[:RF]:ATTenuation <value>	Set attenuator
[:SENSe]:POWer[:RF]:ATTenuation?	Query attenuator
[:SENSe]:POWer[:RF]:ATTenuation:AUTO ON OFF 1 0	Set attenuator ON/OFF
[:SENSe]:POWer[:RF]:ATTenuation:AUTO?	Query attenuator ON/OFF
[:SENSe]:POWer[:RF]:ATTenuation:STEP[:INCRement]	Set attenuator step
[:SENSe]:POWer[:RF]:ATTenuation:STEP[:INCRement]?	Query attenuator step
[:SENSe]:POWer[:RF]:EATTenuation <value>	Set electronic attenuator
[:SENSe]:POWer[:RF]:EATTenuation?	Query electronic attenuator
[:SENSe]:POWer[:RF]:EATTenuation:STATe ON OFF 1 0	Set electronic attenuator ON/OFF
[:SENSe]:POWer[:RF]:EATTenuation:STATe?	Query electronic attenuator ON/OFF
[:SENSe]:POWer[:RF]:GAIN[:STATe] ON OFF 1 0	Set gain ON/OFF
[:SENSe]:POWer[:RF]:GAIN[:STATe]?	Query gain ON/OFF
[:SENSe]:POWer[:RF]:MIXer:RANGe[:UPPer] <value>	Set the maximum mixer level
[:SENSe]:POWer[:RF]:MIXer:RANGe[:UPPer]?	Query maximum mixer level

## Annex B Zoom table of SCPI commands

[:SENSe]:POWer[:RF]:MIXer:RULes NORMal TOI COMPression	Set maximum mixer level rule
[:SENSe]:POWer[:RF]:MIXer:RULes?	Query maximum mixer level rule

Table 8 Zoom table of harmonic distortion SCPI commands

Command	Function
:CONFigure:HARMonics	Enter Harmonic Distortion Measurement Function
:DISPlay:HARMonics:WINDow[1]:TRACe[1]:Y[:SCALe]:PDIVision <value>	Set scale/division
:DISPlay:HARMonics:WINDow[1]:TRACe[1]:Y[:SCALe]:PDIVision?	Query scale/division
:DISPlay:HARMonics:WINDow[1]:TRACe[1]:Y[:SCALe]:RLEVel <value>	Set reference level
:DISPlay:HARMonics:WINDow[1]:TRACe[1]:Y[:SCALe]:RLEVel?	Query reference level
:DISPlay:HARMonics:WINDow[1]:TRACe[1]:Y[:SCALe]:RLEVel:OFFSet <value>	Set reference level offset
:DISPlay:HARMonics:WINDow[1]:TRACe[1]:Y[:SCALe]:RLEVel:OFFSet ?	Query reference level offset
:DISPlay:WINDow[1]:TRACe:Y:DLINe[1]]2--6 <value>	Set amplitude display line
:DISPlay:WINDow[1]:TRACe:Y:DLINe[1]]2--6?	Query amplitude display line
:DISPlay:WINDow[1]:TRACe:Y:DLINe[1]]2--6:STATe ON OFF 1 0	Set amplitude display line ON/OFF
:DISPlay:WINDow[1]:TRACe:Y:DLINe[1]]2--6:STATe?	Query amplitude display line ON/OFF
:FETCh:HARMonics[1]]2?	Query measurement results
:FETCh:HARMonics:AMPLitude:ALL?	Query all amplitude results
:FETCh:HARMonics:AMPLitude[1]]2--10?	Query specified harmonic amplitude
:FETCh:HARMonics:FREQuency:ALL?	Query all frequency results
:FETCh:HARMonics:FREQuency[1]]2--10?	Query specified harmonic frequency
:FETCh:HARMonics:DISTortion?	Query harmonic distortion
:FETCh:HARMonics:FUNDamental?	Query fundamental wave frequency
:MEASure:HARMonics[1]]2?	Query measurement results
:MEASure:HARMonics:AMPLitude:ALL?	Query all amplitude results
:MEASure:HARMonics:AMPLitude[1]]2--10?	Query specified harmonic amplitude
:MEASure:HARMonics:FREQuency:ALL?	Query all frequency results
:MEASure:HARMonics:FREQuency[1]]2--10?	Query specified harmonic frequency
:MEASure:HARMonics:DISTortion?	Query harmonic distortion
:MEASure:HARMonics:FUNDamental?	Query fundamental wave frequency

**Annex B Zoom table of SCPI commands**

:READ:HARMonics[1]]2?	Query measurement results
:READ:HARMonics:AMPLitude:ALL?	Query all amplitude results
:READ:HARMonics:AMPLitude[1]]2--10?	Query specified harmonic amplitude
:READ:HARMonics:FREQuency:ALL?	Query all frequency results
:READ:HARMonics:FREQuency[1]]2--10?	Query specified harmonic frequency
:READ:HARMonics:DISToRtion?	Query harmonic distortion
:READ:HARMonics:FUNDamental?	Query fundamental wave frequency
:INITiate:CONTInuous ON OFF 1 0	Set sweep mode
:INITiate:CONTInuous?	Query sweep mode
:INITiate:REStart	Restart
:INITiate[:IMMEDIATE]	Refresh now
:TRACe:HARMonics:DISPlay[:STATe] ON OFF 1 0	Set trace display ON/OFF
:TRACe:HARMonics:DISPlay[:STATe]?	Query trace display ON/OFF
:TRAC:HARMonics:TYPE WRITe AVERAge MAXHold MINHold	Set trace type
:TRAC:HARMonics:TYPE?	Query trace type
:TRAC:HARMonics:UPDate[:STATe] ON OFF 1 0	Set refresh ON/OFF
:TRAC:HARMonics:UPDate[:STATe]?	Query refresh ON/OFF
:TRIGger[:SEQuence]:HOLDoff <time>	Set trigger OFF time
:TRIGger[:SEQuence]:HOLDoff?	Query trigger block time
:TRIGger[:SEQuence]:HOLDoff:STATe OFF ON 0 1	Set trigger block ON/OFF
:TRIGger[:SEQuence]:HOLDoff:STATe?	Query trigger block ON/OFF
:TRIGger[:SEQuence]:EXTernal[1]]2]3:DELay <time>	Set trigger delay ON/OFF of External Trigger 1, External Trigger 2, and External Trigger 3
:TRIGger[:SEQuence]:EXTernal[1]]2]3:DELay?	Query trigger delay of External Trigger 1, External Trigger 2, and External Trigger 3
:TRIGger[:SEQuence]:EXTernal[1]]2]3:DELay:STATe OFF ON 0 1	Set trigger delay ON/OFF of External Trigger 1, External Trigger 2, and External Trigger 3
:TRIGger[:SEQuence]:EXTernal[1]]2]3:DELay:STATe?	Query trigger delay ON/OFF of External Trigger 1, External Trigger 2, and External Trigger 3
:TRIGger[:SEQuence]:EXTernal[1]]2:LEVel <level>	Set trigger level of External Trigger 1 or External Trigger 2
:TRIGger[:SEQuence]:EXTernal[1]]2:LEVel?	Query trigger level of External Trigger 1 or External Trigger 2
:TRIGger[:SEQuence]:EXTernal[1]]2]3:SLOPe POSitive NEGative	Set the Trigger Slope of External Trigger 1, External Trigger 2, and External Trigger 3
:TRIGger[:SEQuence]:EXTernal[1]]2]3:SLOPe?	Query the Trigger Slope of External Trigger 1, External Trigger 2, and External Trigger 3

## Annex B Zoom table of SCPI commands

:TRIGger[:SEQuence]:FRAMe:DELay <time>	Set Time Trigger delay
:TRIGger[:SEQuence]:FRAMe:DELay?	Query Time Trigger delay
:TRIGger[:SEQuence]:FRAMe:DELay:STATe OFF ON 0 1	Set Trigger Delay ON/OFF of Trigger Timer
:TRIGger[:SEQuence]:FRAMe:DELay:STATe?	Query Trigger Delay ON/OFF of Trigger Timer
:TRIGger[:SEQuence]:FRAMe:OFFSet <time>	Set Time Trigger Offset
:TRIGger[:SEQuence]:FRAMe:OFFSet?	Query Time Trigger Offset
:TRIGger[:SEQuence]:FRAMe:PERiod <time>	Set Time Trigger Cycle
:TRIGger[:SEQuence]:FRAMe:PERiod?	Query Time Trigger Cycle
:TRIGger[:SEQuence]:FRAMe:SYNC EXTernal1 EXTernal2 RFBurst OFF	Sync Source Selection
:TRIGger[:SEQuence]:FRAMe:SYNC?	Query Synchronization Source Selection
:TRIGger[:SEQuence]:FRAMe:SYNC:HOLDoff <time>	Set synchronization source blocking
:TRIGger[:SEQuence]:FRAMe:SYNC:HOLDoff?	Query synchronization source blocking
:TRIGger[:SEQuence]:LINE:DELay <time>	Set power trigger delay
:TRIGger[:SEQuence]:LINE:DELay?	Query power trigger delay
:TRIGger[:SEQuence]:LINE:DELay:STATe OFF ON 0 1	Set power trigger delay ON/OFF
:TRIGger[:SEQuence]:LINE:DELay:STATe?	Query power trigger delay ON/OFF
:TRIGger[:SEQuence]:LINE:SLOPe POSitive NEGative	Set Power Trigger Slope
:TRIGger[:SEQuence]:LINE:SLOPe?	Query Power Trigger Slope
:TRIGger[:SEQuence]:RFBurst:DELay <time>	Set trigger delay of burst signal
:TRIGger[:SEQuence]:RFBurst:DELay?	Query trigger delay of burst signal
:TRIGger[:SEQuence]:RFBurst:DELay:STATe OFF ON 0 1	Set trigger delay ON/OFF of burst signal
:TRIGger[:SEQuence]:RFBurst:DELay:STATe?	Query trigger delay ON/OFF of burst signal
:TRIGger[:SEQuence]:RFBurst:LEVel:ABSolute <ampl>	Set burst signal trigger level
:TRIGger[:SEQuence]:RFBurst:LEVel:ABSolute?	Query burst signal trigger level
:TRIGger[:SEQuence]:RFBurst:SLOPe POSitive NEGative	Set Trigger Slope of Burst Signal Trigger
:TRIGger[:SEQuence]:RFBurst:SLOPe?	Query Trigger Slope of Burst Signal Trigger
:TRIGger[:SEQuence]:SOURce EXTernal1 EXTernal2 EXTernal3 IMMediate LINE FRAMe RFBurst VIDe o	Trigger Mode Selection
:TRIGger[:SEQuence]:SOURce?	Query Trigger Mode Selection
:TRIGger[:SEQuence]:VIDeo:DELay <time>	Set video trigger delay
:TRIGger[:SEQuence]:VIDeo:DELay?	Query video trigger delay
:TRIGger[:SEQuence]:VIDeo:DELay:STATe OFF ON 0 1	Set video trigger delay

**Annex B Zoom table of SCPI commands**

:TRIGger[:SEquence]:VIDeo:DElay:STATe?	Query video trigger delay
:TRIGger[:SEquence]:VIDeo:LEVel <ampl>	Set video trigger level
:TRIGger[:SEquence]:VIDeo:LEVel?	Query video trigger level
:TRIGger[:SEquence]:VIDeo:SLOPe POSitive NEGative	Set Video Trigger Slope
:TRIGger[:SEquence]:VIDeo:SLOPe?	Query Video Trigger Slope
:UNIT:HARMonics:POWer DBM DBM DBMV DBMA V W A DBUV DBUA	Set vertical axis scale
:UNIT:HARMonics:POWer?	Query vertical axis scale
[:SENSe]:HARMonics:FREQuency:CENTer:STEP:AUTO ON OFF 1 0	Set the frequency step ON/OFF
[:SENSe]:HARMonics:FREQuency:CENTer:STEP:AUTO?	Query frequency step ON/OFF
[:SENSe]:HARMonics:FREQuency:CENTer:STEP[:INCRement] <value>	Set the frequency step
[:SENSe] :HARMonics:FREQuency:CENTer:STEP[:INCRement]?	Query frequency step
[:SENSe]:FREQuency:OFFSet <value>	Set frequency offset
[:SENSe]:FREQuency:OFFSet?	Query frequency offset
[:SENSe]:HARMonics:ADC:DITHer:AUTO[:STATe] ON OFF 1 0	Set ADC Dither ON/OFF
[:SENSe]:HARMonics:ADC:DITHer:AUTO[:STATe]?	Query ADC Dither ON/OFF
[:SENSe]:HARMonics:ADC:DITHer[:STATe] ON OFF HIGH	Set ADC Dither
[:SENSe]:HARMonics:ADC:DITHer[:STATe]?	Query ADC Dither
[:SENSe]:HARMonics:ADJust:LEVel	Auto Scaling
[:SENSe]:HARMonics:AVERAge:COUNt <value>	Set average times
[:SENSe]:HARMonics:AVERAge:COUNt?	Query average times
[:SENSe]:HARMonics:AVERAge:TCONtrol EXPOntial  REPeat 1 0	Set the average mode
[:SENSe]:HARMonics:AVERAge:TCONtrol?	Query average mode
[:SENSe]:HARMonics:AVERAge[:STATe] ON OFF 1 0	SetAvgOn
[:SENSe]:HARMonics:AVERAge[:STATe]?	QueryAvgOn
[:SENSe]:HARMonics:BANDwidth BWIDth:VIDeo <value>	Set VBW
[:SENSe]:HARMonics:BANDwidth BWIDth:VIDeo?	QueryVBW
[:SENSe]:HARMonics:BANDwidth BWIDth:VIDeo:AUTO ON OFF 1 0	Set VBW ON/OFF
[:SENSe]:HARMonics:BANDwidth BWIDth:VIDeo:AUTO?	Query VBW ON/OFF
[:SENSe]:HARMonics:BANDwidth BWIDth[:RESolution] <value>	Set RBW
[:SENSe]:HARMonics:BANDwidth BWIDth[:RESolution]?	Query RBW
[:SENSe]:HARMonics:BANDwidth BWIDth[:RESolution]:AUTO ON OFF 1 0	Set RBW ON/OFF
[:SENSe]:HARMonics:BANDwidth BWIDth[:RESolution]:AUTO?	Query RBW ON/OFF

[;SENSe]:HARMonics:DETEctor:AUTO ON OFF 1 0	Set detection mode ON/OFF
[;SENSe]:HARMonics:DETEctor:AUTO?	Query detection mode ON/OFF
[;SENSe]:HARMonics:DETEctor[:FUNctIon] NORMal AVERAge POSitive SAMPle NEGative RMS SCALar	Set detection mode
[;SENSe]:HARMonics:DETEctor[:FUNctIon]?	Query detector mode
[;SENSe]:HARMonics:FREQuency:FUNDamental <value>	Set fundamental wave frequency
[;SENSe]:HARMonics:FREQuency:FUNDamental?	Query fundamental wave frequency
[;SENSe]:HARMonics:FREQuency:FUNDamental:AUTO ON OFF 1 0	Set the fundamental frequency ON/OFF state
[;SENSe]:HARMonics:FREQuency:FUNDamental:AUTO?	Query fundamental frequency ON/OFF
[;SENSe]:HARMonics:NUMBer <value>	Set quantity of harmonic waves
[;SENSe]:HARMonics:NUMBer?	Query the number of harmonics
[;SENSe]:HARMonics:RANGe[:LIST]:BANDwidth BWIDth:VIDeo <value>, <value> ...<value>	Set harmonic list video bandwidth
[;SENSe]:HARMonics:RANGe[:LIST]:BANDwidth BWIDth:VIDeo?	Query harmonic list video bandwidth
[;SENSe]:HARMonics:RANGe[:LIST]:BANDwidth BWIDth:VIDeo:AUTO ON OFF 1 0, ON OFF 1 0... ON OFF 1 0	Set harmonic list video bandwidth ON/OFF
[;SENSe]:HARMonics:RANGe[:LIST]:BANDwidth BWIDth:VIDeo:AUTO ?	Query harmonic list video bandwidth ON/OFF
[;SENSe]:HARMonics:RANGe[:LIST]:BANDwidth BWIDth[:RESolution] <value>, <value> ...<value>	Set harmonic list resolution bandwidth.
[;SENSe]:HARMonics:RANGe[:LIST]:BANDwidth BWIDth[:RESolution] ?	Query harmonic list resolution bandwidth.
[;SENSe]:HARMonics:RANGe[:LIST]:BANDwidth BWIDth[:RESolution] :AUTO ON OFF 1 0, ON OFF 1 0...ON OFF 1 0	Set harmonic list resolution bandwidth ON/OFF
[;SENSe]:HARMonics:RANGe[:LIST]:BANDwidth BWIDth[:RESolution] :AUTO?	Query harmonic list resolution bandwidth ON/OFF
[;SENSe]:HARMonics:RANGe[:LIST]:FREQuency <value>, <value> ...<value>	Set harmonic list frequency
[;SENSe]:HARMonics:RANGe[:LIST]:FREQuency?	Query harmonic list frequency
[;SENSe]:HARMonics:RANGe[:LIST]:STATe ON OFF 1 0, ON OFF 1 0...ON OFF 1 0 <value>, <value> ...<value>	Set harmonic list state
[;SENSe]:HARMonics:RANGe[:LIST]:STATe?	Query harmonic list state
[;SENSe]:HARMonics:RANGe[:LIST]:SWEeptime <value>, <value> ...<value>	Set harmonic list sweep time

**Annex B Zoom table of SCPI commands**

[;SENSe]:HARMonics:RANGe[:LIST]:SWEeptime?	Query harmonic list sweep time
[;SENSe]:HARMonics:RANGe[:LIST]:SWEeptime:AUTO ON OFF 1 0, ON OFF 1 0...ON OFF 1 0	Set harmonic list sweep time ON/OFF
[;SENSe]:HARMonics:RANGe[:LIST]:SWEeptime:AUTO?	Query harmonic list sweep time ON/OFF
[;SENSe]:HARMonics:RTABLE:FILL	Auto Fill List
[;SENSe]:HARMonics:RTABLE:STATe ON OFF 1 0	Set harmonic measurement methods
[;SENSe]:HARMonics:RTABLE:STATe?	Query harmonic measurement methods
[;SENSe]:HARMonics:SWEEp:POINts <value>	Set number of sweep points
[;SENSe]:HARMonics:SWEEp:POINts?	Query number of sweep points
[;SENSe]:HARMonics:SWEEp:TIME <value>	Set SwpTime
[;SENSe]:HARMonics:SWEEp:TIME?	QuerySwpTime
[;SENSe]:HARMonics:SWEEp:TIME:AUTO ON OFF 1 0	Set sweep time ON/OFF
[;SENSe]:HARMonics:SWEEp:TIME:AUTO?	Query sweep time ON/OFF
[;SENSe]:POWer[:RF]:ATTenuation <value>	Set attenuator
[;SENSe]:POWer[:RF]:ATTenuation?	Query attenuator
[;SENSe]:POWer[:RF]:ATTenuation:AUTO ON OFF 1 0	Set attenuator ON/OFF
[;SENSe]:POWer[:RF]:ATTenuation:AUTO?	Query attenuator ON/OFF
[;SENSe]:POWer[:RF]:ATTenuation:STEP[:INCRement]	Set attenuator step
[;SENSe]:POWer[:RF]:ATTenuation:STEP[:INCRement]?	Query attenuator step
[;SENSe]:POWer[:RF]:EATTenuation <value>	Set electronic attenuator
[;SENSe]:POWer[:RF]:EATTenuation?	Query electronic attenuator
[;SENSe]:POWer[:RF]:EATTenuation:STATe ON OFF 1 0	Set electronic attenuator ON/OFF
[;SENSe]:POWer[:RF]:EATTenuation:STATe?	Query electronic attenuator ON/OFF
[;SENSe]:POWer[:RF]:GAIN[:STATe] ON OFF 1 0	Set gain ON/OFF
[;SENSe]:POWer[:RF]:GAIN[:STATe]?	Query gain ON/OFF
[;SENSe]:POWer[:RF]:MIXer:RANGe[:UPPer] <value>	Set the maximum mixer level
[;SENSe]:POWer[:RF]:MIXer:RANGe[:UPPer]?	Query maximum mixer level
[;SENSe]:POWer[:RF]:MIXer:RULeS NORMal TOI COMPReSSion	Set maximum mixer level rule
[;SENSe]:POWer[:RF]:MIXer:RULeS?	Query maximum mixer level rule

**Table 9 Zoom table of third-order intermodulation SCPI commands**

Command	Function
:CALCulate:TOI:MARKer:AOff	Mkr All Off
:CALCulate:TOI:MARKer:COUPle[:STATe] ON OFF 1 0	Set Marker Association ON/OFF

## Annex B Zoom table of SCPI commands

:CALCulate:TOI:MARKer:COUple[:STATe]?	Query Marker Association ON/OFF
:CALCulate:TOI:MARKer:PEAK:EXCursion <value>	Set peak accuracy
:CALCulate:TOI:MARKer:PEAK:EXCursion?	Query peak accuracy
:CALCulate:TOI:MARKer:PEAK:EXCursion:STATe ON OFF 1 0	Set peak accuracy ON/OFF
:CALCulate:TOI:MARKer:PEAK:EXCursion:STATe?	Query peak accuracy ON/OFF
:CALCulate:TOI:MARKer:PEAK:SEARch:MODE MAXimum PARAmeter	Set peak search mode
:CALCulate:TOI:MARKer:PEAK:SEARch:MODE?	Query peak search mode
:CALCulate:TOI:MARKer:PEAK:THReshold <value>	Set peak threshold
:CALCulate:TOI:MARKer:PEAK:THReshold?	Query peak threshold
:CALCulate:TOI:MARKer:PEAK:THReshold:STATe ON OFF 1 0	Set peak threshold ON/OFF
:CALCulate:TOI:MARKer:PEAK:THReshold:STATe?	Query peak threshold ON/OFF
:CALCulate:TOI:MARKer:TABLE[:STATe] ON OFF 1 0	Set marker report ON/OFF
:CALCulate:TOI:MARKer:TABLE[:STATe]?	Query marker report ON/OFF
:CALCulate:TOI:MARKer[1]]2--12:CPSearch[:STATe] ON OFF 1 0	Set the continuous search ON/OFF
:CALCulate:TOI:MARKer[1]]2--12:CPSearch[:STATe]?	Query the continuous search ON/OFF
:CALCulate:TOI:MARKer[1]]2--12:LINEs[:STATe] ON OFF 1 0	Set marker line display ON/OFF
:CALCulate:TOI:MARKer[1]]2--12:LINEs[:STATe]?	Query marker line display ON/OFF
:CALCulate:TOI:MARKer[1]]2--12:MAXimum	Peak Search
:CALCulate:TOI:MARKer[1]]2--12:MAXimum:LEFT	Left peak search
:CALCulate:TOI:MARKer[1]]2--12:MAXimum:NEXT	Sub-peak search
:CALCulate:TOI:MARKer[1]]2--12:MAXimum:RIGHT	Right peak search
:CALCulate:TOI:MARKer[1]]2--12:MINimum	Minimum Search
:CALCulate:TOI:MARKer[1]]2--12:MODE POSition DELTA FIXed OFF	Set the type for the marker
:CALCulate:TOI:MARKer[1]]2--12:MODE?	Query the type for the marker
:CALCulate:TOI:MARKer[1]]2--12:REFerence <value>	Set reference marker
:CALCulate:TOI:MARKer[1]]2--12:REFerence?	Query reference marker
:CALCulate:TOI:MARKer[1]]2--12:STATe ON OFF 1 0	Set marker status
:CALCulate:TOI:MARKer[1]]2--12:STATe?	Query marker state
:CALCulate:TOI:MARKer[1]]2--12:X <value>	Set the marker X value
:CALCulate:TOI:MARKer[1]]2--12:X?	Query the marker X value
:CALCulate:TOI:MARKer[1]]2--12:X:POSition <value>	Set marker X- position
:CALCulate:TOI:MARKer[1]]2--12:X:POSition?	Query marker X- position
:CALCulate:TOI:MARKer[1]]2--12:Y <value>	Set marker Y value

**Annex B Zoom table of SCPI commands**

:CALCulate:TOI:MARKer[1]]2--12:Y?	Query the value of marker X.
:CONFigure:TOI	Enter Third-order Intermodulation Measurement Function
:DISPlay:TOI:WINDow[1]:TRACe[1]:Y[:SCALe]:PDIVision <value>	Set scale/division
:DISPlay:TOI:WINDow[1]:TRACe[1]:Y[:SCALe]:PDIVision?	Query scale/division
:DISPlay:TOI:WINDow[1]:TRACe[1]:Y[:SCALe]:RLEVel <value>	Set reference level
:DISPlay:TOI:WINDow[1]:TRACe[1]:Y[:SCALe]:RLEVel?	Query reference level
:DISPlay:TOI:WINDow[1]:TRACe[1]:Y[:SCALe]:RLEVel:OFFSet <value>	Set reference level offset
:DISPlay:TOI:WINDow[1]:TRACe[1]:Y[:SCALe]:RLEVel:OFFSet?	Query reference level offset
:DISPlay:WINDow[1]:TRACe:X:FLINe[1]]2--6 <value>	Set frequency display line
:DISPlay:WINDow[1]:TRACe:X:FLINe[1]]2--6?	Query frequency display line
:DISPlay:WINDow[1]:TRACe:X:FLINe[1]]2--6:STATe ON OFF 1 0	Set frequency display line ON/OFF
:DISPlay:WINDow[1]:TRACe:X:FLINe[1]]2--6:STATe?	Query frequency display line ON/OFF
:DISPlay:WINDow[1]:TRACe:Y:DLINe[1]]2--6 <value>	Set amplitude display line
:DISPlay:WINDow[1]:TRACe:Y:DLINe[1]]2--6?	Query amplitude display line
:DISPlay:WINDow[1]:TRACe:Y:DLINe[1]]2--6:STATe ON OFF 1 0	Set amplitude display line ON/OFF
:DISPlay:WINDow[1]:TRACe:Y:DLINe[1]]2--6:STATe?	Query amplitude display line ON/OFF
:FETCh:TOI:IP3?	Query third-order truncation results
:FETCh:TOI[0]]1--2?	Query measurement results
:INITiate:CONTInuous ON OFF 1 0	Set sweep mode
:INITiate:CONTInuous?	Query sweep mode
:INITiate:REStart	Restart
:INITiate[:IMMediate]	Refresh now
:MEASure:TOI:IP3?	Query third-order truncation results
:MEASure:TOI[1]]2--4?	Query measurement results
:READ:TOI:IP3?	Query frequency third-order truncation results
:READ:TOI[1]]2--4?	Query measurement results
:TRACe:TOI:DISPlay[:STATe] ON OFF 1 0	Set trace display ON/OFF
:TRACe:TOI:DISPlay[:STATe]?	Query trace display ON/OFF
:TRAC:TOI:TYPE WRITe AVERAge MAXHold MINHold	Set trace type
:TRAC:TOI:TYPE?	Query trace type
:TRAC:TOI:UPDate[:STATe] ON OFF 1 0	Set refresh ON/OFF
:TRAC:TOI:UPDate[:STATe]?	Query refresh ON/OFF
:TRIGger[:SEQuence]:HOLDoff <time>	Set trigger OFF time

## Annex B Zoom table of SCPI commands

:TRIGger[:SEQuence]:HOLDoff?	Query trigger block time
:TRIGger[:SEQuence]:HOLDoff:STATe OFF ON 0 1	Set trigger block ON/OFF
:TRIGger[:SEQuence]:HOLDoff:STATe?	Query trigger block ON/OFF
:TRIGger[:SEQuence]:EXTernal[1] 2 3:DELay <time>	Set trigger delay ON/OFF of External Trigger 1, External Trigger 2, and External Trigger 3
:TRIGger[:SEQuence]:EXTernal[1] 2 3:DELay?	Query trigger delay of External Trigger 1, External Trigger 2, and External Trigger 3
:TRIGger[:SEQuence]:EXTernal[1] 2 3:DELay:STATe OFF ON 0 1	Set trigger delay ON/OFF of External Trigger 1, External Trigger 2, and External Trigger 3
:TRIGger[:SEQuence]:EXTernal[1] 2 3:DELay:STATe?	Query trigger delay ON/OFF of External Trigger 1, External Trigger 2, and External Trigger 3
:TRIGger[:SEQuence]:EXTernal[1] 2:LEVel <level>	Set trigger level of External Trigger 1 or External Trigger 2
:TRIGger[:SEQuence]:EXTernal[1] 2:LEVel?	Query trigger level of External Trigger 1 or External Trigger 2
:TRIGger[:SEQuence]:EXTernal[1] 2 3:SLOPe POSitive NEGative	Set the Trigger Slope of External Trigger 1, External Trigger 2, and External Trigger 3
:TRIGger[:SEQuence]:EXTernal[1] 2 3:SLOPe?	Query the Trigger Slope of External Trigger 1, External Trigger 2, and External Trigger 3
:TRIGger[:SEQuence]:FRAMe:DELay <time>	Set Time Trigger delay
:TRIGger[:SEQuence]:FRAMe:DELay?	Query Time Trigger delay
:TRIGger[:SEQuence]:FRAMe:DELay:STATe OFF ON 0 1	Set Trigger Delay ON/OFF of Trigger Timer
:TRIGger[:SEQuence]:FRAMe:DELay:STATe?	Query Trigger Delay ON/OFF of Trigger Timer
:TRIGger[:SEQuence]:FRAMe:OFFSet <time>	Set Time Trigger Offset
:TRIGger[:SEQuence]:FRAMe:OFFSet?	Query Time Trigger Offset
:TRIGger[:SEQuence]:FRAMe:PERiod <time>	Set Time Trigger Cycle
:TRIGger[:SEQuence]:FRAMe:PERiod?	Query Time Trigger Cycle
:TRIGger[:SEQuence]:FRAMe:SYNC EXTernal1 EXTernal2 RFBurst OFF	Sync Source Selection
:TRIGger[:SEQuence]:FRAMe:SYNC?	Query Synchronization Source Selection
:TRIGger[:SEQuence]:FRAMe:SYNC:HOLDoff <time>	Set synchronization source blocking
:TRIGger[:SEQuence]:FRAMe:SYNC:HOLDoff?	Query synchronization source blocking
:TRIGger[:SEQuence]:LINE:DELay <time>	Set power trigger delay
:TRIGger[:SEQuence]:LINE:DELay?	Query power trigger delay
:TRIGger[:SEQuence]:LINE:DELay:STATe OFF ON 0 1	Set power trigger delay ON/OFF
:TRIGger[:SEQuence]:LINE:DELay:STATe?	Query power trigger delay ON/OFF
:TRIGger[:SEQuence]:LINE:SLOPe POSitive NEGative	Set Power Trigger Slope

**Annex B Zoom table of SCPI commands**

:TRIGger[:SEquence]:LINE:SLOPe?	Query Power Trigger Slope
:TRIGger[:SEquence]:RFBurst:DELAy <time>	Set trigger delay of burst signal
:TRIGger[:SEquence]:RFBurst:DELAy?	Query trigger delay of burst signal
:TRIGger[:SEquence]:RFBurst:DELAy:STATe OFF ON 0 1	Set trigger delay ON/OFF of burst signal
:TRIGger[:SEquence]:RFBurst:DELAy:STATe?	Query trigger delay ON/OFF of burst signal
:TRIGger[:SEquence]:RFBurst:LEVel:ABSolute <ampl>	Set burst signal trigger level
:TRIGger[:SEquence]:RFBurst:LEVel:ABSolute?	Query burst signal trigger level
:TRIGger[:SEquence]:RFBurst:SLOPe POSitive NEGative	Set Trigger Slope of Burst Signal Trigger
:TRIGger[:SEquence]:RFBurst:SLOPe?	Query Trigger Slope of Burst Signal Trigger
:TRIGger[:SEquence]:SOURce EXTErnal1 EXTErnal2 EXTErnal3 IMMediate LINE FRAME RFBurst VIDe o	Trigger Mode Selection
:TRIGger[:SEquence]:SOURce?	Query Trigger Mode Selection
:TRIGger[:SEquence]:VIDeo:DELAy <time>	Set video trigger delay
:TRIGger[:SEquence]:VIDeo:DELAy?	Query video trigger delay
:TRIGger[:SEquence]:VIDeo:DELAy:STATe OFF ON 0 1	Set video trigger delay
:TRIGger[:SEquence]:VIDeo:DELAy:STATe?	Query video trigger delay
:TRIGger[:SEquence]:VIDeo:LEVel <ampl>	Set video trigger level
:TRIGger[:SEquence]:VIDeo:LEVel?	Query video trigger level
:TRIGger[:SEquence]:VIDeo:SLOPe POSitive NEGative	Set Video Trigger Slope
:TRIGger[:SEquence]:VIDeo:SLOPe?	Query Video Trigger Slope
:UNIT:TOI:POWer DBM DBM DBMV DBMA V W A DBUV DBUA	Set vertical axis scale
:UNIT:TOI:POWer?	Query vertical axis scale
[[:SENSe]:FREQuency:CENTer <value>	Set center frequency
[[:SENSe]:FREQuency:CENTer?	Query center frequency
[[:SENSe]:FREQuency:CENTer:STEP:AUTO ON OFF 1 0	Set the frequency step ON/OFF
[[:SENSe]:FREQuency:CENTer:STEP:AUTO?	Query frequency step ON/OFF
[[:SENSe]:FREQuency:CENTer:STEP[:INCRement] <value>	Set the frequency step
[[:SENSe]:FREQuency:CENTer:STEP[:INCRement]?	Query frequency step
[[:SENSe]:FREQuency:OFFSet <value>	Set frequency offset
[[:SENSe]:FREQuency:OFFSet?	Query frequency offset
[[:SENSe]:FREQuency:SPAN:FULL	Full span
[[:SENSe]:FREQuency:SPAN:PREVious	Previous Span
[[:SENSe]:FREQuency:TUNE:IMMediate	Automatic tuning

## Annex B Zoom table of SCPI commands

[[:SENSe]:TOI:ADC:DITHer:AUTO[:STATe] ON OFF]1 0	Set ADC Dither ON/OFF
[[:SENSe]:TOI:ADC:DITHer:AUTO[:STATe]?	Query ADC Dither ON/OFF
[[:SENSe]:TOI:ADC:DITHer[:STATe] ON OFF]HIGH	Set ADC Dither
[[:SENSe]:TOI:ADC:DITHer[:STATe]?	Query ADC Dither
[[:SENSe]:TOI:ADJust:LEVel	Auto Scaling
[[:SENSe]:TOI:AVERAge:COUnT <value>	Set average times
[[:SENSe]:TOI:AVERAge:COUnT?	Query average times
[[:SENSe]:TOI:AVERAge:TCONtrol EXPOntial  REPeat]1 0	Set the average mode
[[:SENSe]:TOI:AVERAge:TCONtrol?	Query average mode
[[:SENSe]:TOI:AVERAge[:STATe] ON OFF]1 0	SetAvgOn
[[:SENSe]:TOI:AVERAge[:STATe]?	QueryAvgOn
[[:SENSe]:TOI:BANDwidth BWIDth:SHAPE GAUSSian FLATtop	Set the filter type
[[:SENSe]:TOI:BANDwidth BWIDth:SHAPE?	Query filter type
[[:SENSe]:TOI:BANDwidth BWIDth:TYPE DB3 DB6	Set filter bandwidth
[[:SENSe]:TOI:BANDwidth BWIDth:TYPE?	Query filter bandwidth
[[:SENSe]:TOI:BANDwidth BWIDth:VIDeo <value>	Set VBW
[[:SENSe]:TOI:BANDwidth BWIDth:VIDeo?	QueryVBW
[[:SENSe]:TOI:BANDwidth BWIDth:VIDeo:AUTO ON OFF]1 0	Set VBW ON/OFF
[[:SENSe]:TOI:BANDwidth BWIDth:VIDeo:AUTO?	Query VBW ON/OFF
[[:SENSe]:TOI:BANDwidth BWIDth:VIDeo:RATio <value>	Set VBW/RBW
[[:SENSe]:TOI:BANDwidth BWIDth:VIDeo:RATio?	Query VBW/RBW
[[:SENSe]:TOI:BANDwidth BWIDth:VIDeo:RATio:AUTO ON OFF]1 0	Set VBW/RBW ON/OFF
[[:SENSe]:TOI:BANDwidth BWIDth:VIDeo:RATio:AUTO?	Query VBW/RBW ON/OFF
[[:SENSe]:TOI:BANDwidth BWIDth[:RESolution] <value>	Set RBW
[[:SENSe]:TOI:BANDwidth BWIDth[:RESolution]?	Query RBW
[[:SENSe]:TOI:BANDwidth BWIDth[:RESolution]:AUTO ON OFF]1 0	Set RBW ON/OFF
[[:SENSe]:TOI:BANDwidth BWIDth[:RESolution]:AUTO?	Query RBW ON/OFF
[[:SENSe]:TOI:DETEctor:AUTO ON OFF]1 0	Set detection mode ON/OFF
[[:SENSe]:TOI:DETEctor:AUTO?	Query detection mode ON/OFF
[[:SENSe]:TOI:DETEctor[:FUNction] NORMal AVERAge POSitive SAMPle NEGative RMS SCALar	Set detection mode
[[:SENSe]:TOI:DETEctor[:FUNction]?	Query detector mode

**Annex B Zoom table of SCPI commands**

[;SENSe]:TOI:FREQuency:BASE:LOWer <value>	Set low-end fundamental frequency
[;SENSe]:TOI:FREQuency:BASE:LOWer?	Query low-end fundamental frequency
[;SENSe]:TOI:FREQuency:BASE:LOWer:AUTO ON OFF 1 0	Set low-end fundamental frequency ON/OFF state
[;SENSe]:TOI:FREQuency:BASE:LOWer:AUTO	Query low-end fundamental frequency ON/OFF
[;SENSe]:TOI:FREQuency:BASE:UPPer <value>	Set high-end fundamental frequency
[;SENSe]:TOI:FREQuency:BASE:UPPer?	Set high-end fundamental frequency
[;SENSe]:TOI:FREQuency:BASE:UPPer:AUTO ON OFF 1 0	Set high-end fundamental frequency ON/OFF
[;SENSe]:TOI:FREQuency:BASE:UPPer:AUTO?	Query high-end fundamental frequency ON/OFF
[;SENSe]:TOI:FREQuency:SPAN:BANDwidth[:RESolution]:RATio <value>	Set span/rbw
[;SENSe]:TOI:FREQuency:SPAN:BANDwidth[:RESolution]:RATio?	Query span/rbw
[;SENSe]:TOI:FREQuency:SPAN:BANDwidth[:RESolution]:RATio:AUTO ON OFF 1 0	Set span/rbw ON/OFF
[;SENSe]:TOI:FREQuency:SPAN:BANDwidth[:RESolution]:RATio:AUTO?	Query span/rbw ON/OFF
[;SENSe]:TOI:SWEep:FFT:WIDTh <value>	Set FFT width
[;SENSe]:TOI:SWEep:FFT:WIDTh?	Query FFT width
[;SENSe]:TOI:SWEep:FFT:WIDTh:AUTO ON OFF 1 0	Set FFT width ON/OFF
[;SENSe]:TOI:SWEep:FFT:WIDTh:AUTO?	Query FFT width ON/OFF
[;SENSe]:TOI:SWEep:POINts <value>	Set number of sweep points
[;SENSe]:TOI:SWEep:POINts?	Query number of sweep points
[;SENSe]:TOI:SWEep:TIME <value>	Set SwpTime
[;SENSe]:TOI:SWEep:TIME?	QuerySwpTime
[;SENSe]:TOI:SWEep:TIME:AUTO ON OFF 1 0	Set sweep time ON/OFF
[;SENSe]:TOI:SWEep:TIME:AUTO?	Query sweep time ON/OFF
[;SENSe]:TOI:SWEep:TIME:AUTO:RULEs NORMal ACCuracy SRESPonse	Set sweep time AUTO rule
[;SENSe]:TOI:SWEep:TIME:AUTO:RULEs?	Query sweep time AUTO rule
[;SENSe]:TOI:SWEep:TYPE FFT SWEep	SetSwpType
[;SENSe]:TOI:SWEep:TYPE?	QuerySwpType
[;SENSe]:TOI:SWEep:TYPE:AUTO ON OFF 1 0	Set sweep type ON/OFF
[;SENSe]:TOI:SWEep:TYPE:AUTO?	Query sweep type ON/OFF
[;SENSe]:TOI:SWEep:TYPE:AUTO:RULEs SPEed DRANge	Set sweep type Auto rule
[;SENSe]:TOI:SWEep:TYPE:AUTO:RULEs?	Query sweep type Auto rule

## Annex B Zoom table of SCPI commands

[;SENSe]:TOI:SWEp:TYPE:AUTO:RULEs:AUTO[;STATe] ON OFF 1 0	Set sweep type rule ON/OFF
[;SENSe]:TOI:SWEp:TYPE:AUTO:RULEs:AUTO[;STATe]?	Query sweep type rule ON/OFF
[;SENSe]:TOI:ZSPan:BANDwidth BWIDth <value>	Set zero span measurement bandwidth
[;SENSe]:TOI:ZSPan:BANDwidth BWIDth?	Query zero span measurement bandwidth
[;SENSe]:TOI:ZSPan:BANDwidth BWIDth:AUTO ON OFF 1 0	Set zero span measurement bandwidth ON/OFF
[;SENSe]:TOI:ZSPan:BANDwidth BWIDth:AUTO?	Query zero span measurement bandwidth ON/OFF
[;SENSe]:TOI:ZSPan:STATe ON OFF 1 0	Set zero span measurement ON/OFF
[;SENSe]:TOI:ZSPan:STATe?	Query zero span measurement ON/OFF
[;SENSe]:TOI:ZSPan:SWEp:TIME <value>	Set zero span measurement time
[;SENSe]:TOI:ZSPan:SWEp:TIME?	Query zero span measurement time
[;SENSe]:TOI:ZSPan:SWEp:TIME:AUTO ON OFF 1 0	Set zero span measurement time ON/OFF
[;SENSe]:TOI:ZSPan:SWEp:TIME:AUTO?	Query zero span measurement time ON/OFF
[;SENSe]:POWer[:RF]:GAIN[;STATe] ON OFF 1 0	Set gain ON/OFF
[;SENSe]:POWer[:RF]:GAIN[;STATe]?	Query gain ON/OFF
[;SENSe]:POWer[:RF]:MIXer:RANGe[:UPPer] <value>	Set the maximum mixer level
[;SENSe]:POWer[:RF]:MIXer:RANGe[:UPPer]?	Query maximum mixer level
[;SENSe]:POWer[:RF]:MIXer:RULEs NORMal TOI COMPReSSion	Set maximum mixer level rule
[;SENSe]:POWer[:RF]:MIXer:RULEs?	Query maximum mixer level rule

Table 10 Zoom table of spurious emission SCPI commands

Command	Function
:CALCulate:SPURious:MARKer:AOff	Mkr All Off
:CALCulate:SPURious:MARKer:COUPle[;STATe] ON OFF 1 0	Set Marker Association ON/OFF
:CALCulate:SPURious:MARKer:COUPle[;STATe]?	Query Marker Association ON/OFF
:CALCulate:SPURious:MARKer:PEAK:EXCURsion <value>	Set peak accuracy
:CALCulate:SPURious:MARKer:PEAK:EXCURsion?	Query peak accuracy
:CALCulate:SPURious:MARKer:PEAK:EXCURsion:STATe ON OFF 1 0	Set peak accuracy ON/OFF
:CALCulate:SPURious:MARKer:PEAK:EXCURsion:STATe?	Query peak accuracy ON/OFF
:CALCulate:SPURious:MARKer:PEAK:SEARch:MODE MAXimum PARAmeter	Set peak search mode
:CALCulate:SPURious:MARKer:PEAK:SEARch:MODE?	Query peak search mode
:CALCulate:SPURious:MARKer:PEAK:THReshold <value>	Set peak threshold
:CALCulate:SPURious:MARKer:PEAK:THReshold?	Query peak threshold
:CALCulate:SPURious:MARKer:PEAK:THReshold:STATe ON OFF 1 0	Set peak threshold ON/OFF

## Annex B Zoom table of SCPI commands

:CALCulate:SPURious:MARKer:PEAK:THReshold:STATe?	Query peak threshold ON/OFF
:CALCulate:SPURious:MARKer:TABLE[:STATe] ON OFF 1 0	Set marker report ON/OFF
:CALCulate:SPURious:MARKer:TABLE[:STATe]?	Query marker report ON/OFF
:CALCulate:SPURious:MARKer[1] 2--12:CPSearch[:STATe] ON OFF 1 0	Set the continuous search ON/OFF
:CALCulate:SPURious:MARKer[1] 2--12:CPSearch[:STATe]?	Query the continuous search ON/OFF
:CALCulate:SPURious:MARKer[1] 2--12:LINEs[:STATe] ON OFF 1 0	Set marker line display ON/OFF
:CALCulate:SPURious:MARKer[1] 2--12:LINEs[:STATe]?	Query marker line display ON/OFF
:CALCulate:SPURious:MARKer[1] 2--12:MAXimum	Peak Search
:CALCulate:SPURious:MARKer[1] 2--12:MAXimum:LEFT	Left peak search
:CALCulate:SPURious:MARKer[1] 2--12:MAXimum:NEXT	Sub-peak search
:CALCulate:SPURious:MARKer[1] 2--12:MAXimum:RIGHT	Right peak search
:CALCulate:SPURious:MARKer[1] 2--12:MINimum	Minimum Search
:CALCulate:SPURious:MARKer[1] 2--12:MODE POSition DELTA FIXed OFF	Set the type for the marker
:CALCulate:SPURious:MARKer[1] 2--12:MODE?	Query the type for the marker
:CALCulate:SPURious:MARKer[1] 2--12:REFerence <value>	Set reference marker
:CALCulate:SPURious:MARKer[1] 2--12:REFerence?	Query reference marker
:CALCulate:SPURious:MARKer[1] 2--12:STATe ON OFF 1 0	Set marker status
:CALCulate:SPURious:MARKer[1] 2--12:STATe?	Query marker state
:CALCulate:SPURious:MARKer[1] 2--12:X <value>	Set the marker X value
:CALCulate:SPURious:MARKer[1] 2--12:X?	Query the marker X value
:CALCulate:SPURious:MARKer[1] 2--12:X:POSition <value>	Set marker X- position
:CALCulate:SPURious:MARKer[1] 2--12:X:POSition?	Query marker X- position
:CALCulate:SPURious:MARKer[1] 2--12:Y <value>	Set marker Y value
:CALCulate:SPURious:MARKer[1] 2--12:Y?	Query the value of marker X.
:CONFigure:SPURious	Access to Spurious Emission Measurement Function
:CALCulate:SPURious[:RANGe][:LIST]:LIMit:ABSolute[:UPPer]:DATA:STOP <value>,<value> ...<value>	Set range list absolute stop limit
:CALCulate:SPURious[:RANGe][:LIST]:LIMit:ABSolute[:UPPer]:DATA:STOP?	Query range list absolute stop limit
:CALCulate:SPURious[:RANGe][:LIST]:LIMit:ABSolute[:UPPer]:DATA:STOP:AUTO ON OFF 1 0, ON OFF 1 0...ON OFF 1 0	Set range list absolute stop limit ON/OFF
:CALCulate:SPURious[:RANGe][:LIST]:LIMit:ABSolute[:UPPer]:DATA:STOP:AUTO?	Query range list absolute stop limit ON/OFF

## Annex B Zoom table of SCPI commands

:CALCulate:SPURious[:RANGe][:LIST]:LIMit:ABSolute[:UPPer]:DATA[:START] <value>, <value> ... <value>	Set range list absolute start limit
:CALCulate:SPURious[:RANGe][:LIST]:LIMit:ABSolute[:UPPer]:DATA[:START]?	Query range list absolute start limit
:DISPlay:SPURious:WINDow[1]:TRACe[1]:Y[:SCALe]:PDIVision <value>	Set scale/division
:DISPlay:SPURious:WINDow[1]:TRACe[1]:Y[:SCALe]:PDIVision?	Query scale/division
:DISPlay:SPURious:WINDow[1]:TRACe[1]:Y[:SCALe]:RLEVel <value>	Set reference level
:DISPlay:SPURious:WINDow[1]:TRACe[1]:Y[:SCALe]:RLEVel?	Query reference level
:DISPlay:SPURious:WINDow[1]:TRACe[1]:Y[:SCALe]:RLEVel:OFFSet <value>	Set reference level offset
:DISPlay:SPURious:WINDow[1]:TRACe[1]:Y[:SCALe]:RLEVel:OFFSet?	Query reference level offset
:DISPlay:WINDow[1]:TRACe:Y:DLINe[1]]2--6 <value>	Set amplitude display line
:DISPlay:WINDow[1]:TRACe:Y:DLINe[1]]2--6?	Query amplitude display line
:DISPlay:WINDow[1]:TRACe:Y:DLINe[1]]2--6:STATe ON OFF 1 0	Set amplitude display line ON/OFF
:DISPlay:WINDow[1]:TRACe:Y:DLINe[1]]2--6:STATe?	Query amplitude display line ON/OFF
:FETCh:SPURious[1]]2--42?	Query measurement results
:INITiate:CONTinuous ON OFF 1 0	Set sweep mode
:INITiate:CONTinuous?	Query sweep mode
:INITiate:REStart	Restart
:INITiate[:IMMediate]	Refresh now
:MEASure:SPURious[1]]2--42?	Query measurement results
:READ:SPURious[1]]2--42?	Query measurement results
:TRIGger[:SEQuence]:HOLDoff <time>	Set trigger OFF time
:TRIGger[:SEQuence]:HOLDoff?	Query trigger block time
:TRIGger[:SEQuence]:HOLDoff:STATe OFF ON 0 1	Set trigger block ON/OFF
:TRIGger[:SEQuence]:HOLDoff:STATe?	Query trigger block ON/OFF
:TRIGger[:SEQuence]:EXTernal[1]]2]3:DELay <time>	Set trigger delay ON/OFF of External Trigger 1, External Trigger 2, and External Trigger 3
:TRIGger[:SEQuence]:EXTernal[1]]2]3:DELay?	Query trigger delay of External Trigger 1, External Trigger 2, and External Trigger 3
:TRIGger[:SEQuence]:EXTernal[1]]2]3:DELay:STATe OFF ON 0 1	Set trigger delay ON/OFF of External Trigger 1, External Trigger 2, and External Trigger 3
:TRIGger[:SEQuence]:EXTernal[1]]2]3:DELay:STATe?	Query trigger delay ON/OFF of External Trigger 1, External Trigger 2, and External Trigger 3

**Annex B Zoom table of SCPI commands**

:TRIGger[:SEquence]:EXTernal[1] 2:LEVel <level>	Set trigger level of External Trigger 1 or External Trigger 2
:TRIGger[:SEquence]:EXTernal[1] 2:LEVel?	Query trigger level of External Trigger 1 or External Trigger 2
:TRIGger[:SEquence]:EXTernal[1] 2 3:SLOPe POSitive NEGative	Set the Trigger Slope of External Trigger 1, External Trigger 2, and External Trigger 3
:TRIGger[:SEquence]:EXTernal[1] 2 3:SLOPe?	Query the Trigger Slope of External Trigger 1, External Trigger 2, and External Trigger 3
:TRIGger[:SEquence]:FRAMe:DELay <time>	Set Time Trigger delay
:TRIGger[:SEquence]:FRAMe:DELay?	Query Time Trigger delay
:TRIGger[:SEquence]:FRAMe:DELay:STATe OFF ON 0 1	Set Trigger Delay ON/OFF of Trigger Timer
:TRIGger[:SEquence]:FRAMe:DELay:STATe?	Query Trigger Delay ON/OFF of Trigger Timer
:TRIGger[:SEquence]:FRAMe:OFFSet <time>	Set Time Trigger Offset
:TRIGger[:SEquence]:FRAMe:OFFSet?	Query Time Trigger Offset
:TRIGger[:SEquence]:FRAMe:PERiod <time>	Set Time Trigger Cycle
:TRIGger[:SEquence]:FRAMe:PERiod?	Query Time Trigger Cycle
:TRIGger[:SEquence]:FRAMe:SYNC EXTernal1 EXTernal2 RFBurst OFF	Sync Source Selection
:TRIGger[:SEquence]:FRAMe:SYNC?	Query Synchronization Source Selection
:TRIGger[:SEquence]:FRAMe:SYNC:HOLDoff <time>	Set synchronization source blocking
:TRIGger[:SEquence]:FRAMe:SYNC:HOLDoff?	Query synchronization source blocking
:TRIGger[:SEquence]:LINE:DELay <time>	Set power trigger delay
:TRIGger[:SEquence]:LINE:DELay?	Query power trigger delay
:TRIGger[:SEquence]:LINE:DELay:STATe OFF ON 0 1	Set power trigger delay ON/OFF
:TRIGger[:SEquence]:LINE:DELay:STATe?	Query power trigger delay ON/OFF
:TRIGger[:SEquence]:LINE:SLOPe POSitive NEGative	Set Power Trigger Slope
:TRIGger[:SEquence]:LINE:SLOPe?	Query Power Trigger Slope
:TRIGger[:SEquence]:RFBurst:DELay <time>	Set trigger delay of burst signal
:TRIGger[:SEquence]:RFBurst:DELay?	Query trigger delay of burst signal
:TRIGger[:SEquence]:RFBurst:DELay:STATe OFF ON 0 1	Set trigger delay ON/OFF of burst signal
:TRIGger[:SEquence]:RFBurst:DELay:STATe?	Query trigger delay ON/OFF of burst signal
:TRIGger[:SEquence]:RFBurst:LEVel:ABSolute <ampl>	Set burst signal trigger level
:TRIGger[:SEquence]:RFBurst:LEVel:ABSolute?	Query burst signal trigger level
:TRIGger[:SEquence]:RFBurst:SLOPe POSitive NEGative	Set Trigger Slope of Burst Signal Trigger
:TRIGger[:SEquence]:RFBurst:SLOPe?	Query Trigger Slope of Burst Signal Trigger

:TRIGger[:SEQuence]:SOURce EXternal1 EXternal2 EXternal3 IMMediate LINE FRAME RFBurst VIDeo	Trigger Mode Selection
:TRIGger[:SEQuence]:SOURce?	Query Trigger Mode Selection
:TRIGger[:SEQuence]:VIDeo:DELay <time>	Set video trigger delay
:TRIGger[:SEQuence]:VIDeo:DELay?	Query video trigger delay
:TRIGger[:SEQuence]:VIDeo:DELay:STATe OFF ON 0 1	Set video trigger delay
:TRIGger[:SEQuence]:VIDeo:DELay:STATe?	Query video trigger delay
:TRIGger[:SEQuence]:VIDeo:LEVel <ampl>	Set video trigger level
:TRIGger[:SEQuence]:VIDeo:LEVel?	Query video trigger level
:TRIGger[:SEQuence]:VIDeo:SLOPe POSitive NEGative	Set Video Trigger Slope
:TRIGger[:SEQuence]:VIDeo:SLOPe?	Query Video Trigger Slope
:UNIT:SPURious:POWer DBM DBM DBMV DBMA V W A DBUV DBUA	Set vertical axis scale
:UNIT:SPURious:POWer?	Query vertical axis scale
[:SENSe]:SPURious:ADC:DITHer:AUTO[:STATe] ON OFF 1 0	Set ADC Dither ON/OFF
[:SENSe]:SPURious:ADC:DITHer:AUTO[:STATe]?	Query ADC Dither ON/OFF
[:SENSe]:SPURious:ADC:DITHer[:STATe] ON OFF HIGH	Set ADC Dither
[:SENSe]:SPURious:ADC:DITHer[:STATe]?	Query ADC Dither
[:SENSe]:SPURious:ADJust:LEVel	Auto Scaling
[:SENSe]:SPURious:AVERage:COUNT <value>	Set average times
[:SENSe]:SPURious:AVERage:COUNT?	Query average times
[:SENSe]:SPURious:AVERage:TCONtrol EXPonential  REPeat 1 0	Set the average mode
[:SENSe]:SPURious:AVERage:TCONtrol?	Query average mode
[:SENSe]:SPURious:AVERage[:STATe] ON OFF 1 0	SetAvgOn
[:SENSe]:SPURious:AVERage[:STATe]?	QueryAvgOn
[:SENSe]:SPURious:REPT:MODE ALL LIMTest MMARgin	SetMeasTarget
[:SENSe]:SPURious:REPT:MODE?	QueryMeasTarget
[:SENSe]:SPURious:SWEep:TYPE FFT SWEep	SetSwpType
[:SENSe]:SPURious:SWEep:TYPE?	QuerySwpType
[:SENSe]:SPURious:SWEep:TYPE:AUTO ON OFF 1 0	Set sweep type Automatic ON/OFF
[:SENSe]:SPURious:SWEep:TYPE:AUTO?	Query sweep type Automatic ON/OFF
[:SENSe]:SPURious:SWEep:TYPE:AUTO:RULes SPEed DRANge	Set sweep type Auto rule

## Annex B Zoom table of SCPI commands

[;SENSe]:SPURious:SWEEP:TYPE:AUTO:RULEs?	Query sweep type Auto rule
[;SENSe]:SPURious:SWEEP:TIME:AUTO:RULEs NORMal ACCuracy SRESPonse	Set sweep time AUTO rule
[;SENSe]:SPURious:SWEEP:TIME:AUTO:RULEs?	Query sweep time AUTO rule
[;SENSe]:SPURious[:RANGE][:LIST]:ATTenuation <value>, <value> ...<value>	Set range list attenuation
[;SENSe]:SPURious[:RANGE][:LIST]:ATTenuation?	Query range list attenuation
[;SENSe]:SPURious[:RANGE][:LIST]:ATTenuation:AUTO ON OFF 1 0, ON OFF 1 0...ON OFF 1 0	Set range list attenuation ON/OFF
[;SENSe]:SPURious[:RANGE][:LIST]:ATTenuation:AUTO?	Query range list attenuation ON/OFF
[;SENSe]:SPURious[:RANGE][:LIST]:BANDwidth:SHAPE GAUSSian FLATtop, GAUSSian FLATtop...GAUSSian FLATtop	Set range list filter type
[;SENSe]:SPURious[:RANGE][:LIST]:BANDwidth:SHAPE?	Query range list filter type
[;SENSe]:SPURious[:RANGE][:LIST]:BANDwidth:VIDeo <value>, <value> ...<value>	Set range list video bandwidth
[;SENSe]:SPURious[:RANGE][:LIST]:BANDwidth:VIDeo?	Query range list video bandwidth
[;SENSe]:SPURious[:RANGE][:LIST]:BANDwidth:VIDeo:AUTO ON OFF 1 0, ON OFF 1 0...ON OFF 1 0	Set range list video bandwidth ON/OFF
[;SENSe]:SPURious[:RANGE][:LIST]:BANDwidth:VIDeo:AUTO?	Query range list video bandwidth ON/OFF
[;SENSe]:SPURious[:RANGE][:LIST]:BANDwidth[:RESolution] <value>, <value> ...<value>	Set range list resolution bandwidth
[;SENSe]:SPURious[:RANGE][:LIST]:BANDwidth[:RESolution]?	Query range list resolution bandwidth
[;SENSe]:SPURious[:RANGE][:LIST]:BANDwidth[:RESolution]:AUTO ON OFF 1 0, ON OFF 1 0...ON OFF 1 0	Set range list resolution bandwidth ON/OFF
[;SENSe]:SPURious[:RANGE][:LIST]:BANDwidth[:RESolution]:AUTO?	Query range list resolution bandwidth ON/OFF
[;SENSe]:SPURious[:RANGE][:LIST]:DETEctor[1][:FUNction] NORMal AVERage   POSitive SAMPle  NEGative  RMS SCALar, NORMal AVERage   POSitive SAMPle  NEGative  RMS SCALar ...NORMal AVERage   POSitive SAMPle  NEGative  RMS SCALar	Set range list detection method
[;SENSe]:SPURious[:RANGE][:LIST]:DETEctor[1][:FUNction]?	Query range list detection method
[;SENSe]:SPURious[:RANGE][:LIST]:FREQUENCY:START <value>, <value> ...<value>	Set range list start frequency
[;SENSe]:SPURious[:RANGE][:LIST]:FREQUENCY:START?	Query range list start frequency
[;SENSe]:SPURious[:RANGE][:LIST]:FREQUENCY:STOP <value>, <value> ...<value>	Set range list stop frequency
[;SENSe]:SPURious[:RANGE][:LIST]:FREQUENCY:STOP?	Query range list stop frequency

[:SENSe]:SPURious[:RANGe][:LIST]:PEAK:EXCursion <value>, <value> ...<value>	Set range list peak precision
[:SENSe]:SPURious[:RANGe][:LIST]:PEAK:EXCursion?	Query range list peak precision
[:SENSe]:SPURious[:RANGe][:LIST]:PEAK:THReshold <value>, <value> ...<value>	Set range list peak threshold
[:SENSe]:SPURious[:RANGe][:LIST]:PEAK:THReshold?	Query range list peak threshold
[:SENSe]:SPURious[:RANGe][:LIST]:STATe ON OFF 1 0, ON OFF 1 0...ON OFF 1 0	Set range list ON/OFF
[:SENSe]:SPURious[:RANGe][:LIST]:STATe?	Query range list ON/OFF
[:SENSe]:SPURious[:RANGe][:LIST]:SWEep:POINts <value>, <value> ...<value>	Set the range list sweep points
[:SENSe]:SPURious[:RANGe][:LIST]:SWEep:POINts?	Query the range list sweep points
[:SENSe]:SPURious[:RANGe][:LIST]:SWEep:POINts:AUTO ON OFF 1 0, ON OFF 1 0...ON OFF 1 0	Set the range list sweep points ON/OFF
[:SENSe]:SPURious[:RANGe][:LIST]:SWEep:POINts:AUTO?	Query range list sweep points ON/OFF
[:SENSe]:SPURious[:RANGe][:LIST]:SWEep:TIME <value>, <value> ...<value>	Set range list sweep time
[:SENSe]:SPURious[:RANGe][:LIST]:SWEep:TIME?	Query range list sweep time
[:SENSe]:SPURious[:RANGe][:LIST]:SWEep:TIME:AUTO ON OFF 1 0, ON OFF 1 0...ON OFF 1 0	Set range list sweep time ON/OFF
[:SENSe]:SPURious[:RANGe][:LIST]:SWEep:TIME:AUTO?	Query range list sweep time ON/OFF
[:SENSe]:POWer[:RF]:ATTenuation <value>	Set attenuator
[:SENSe]:POWer[:RF]:ATTenuation?	Query attenuator
[:SENSe]:POWer[:RF]:ATTenuation:AUTO ON OFF 1 0	Set attenuator ON/OFF
[:SENSe]:POWer[:RF]:ATTenuation:AUTO?	Query attenuator ON/OFF
[:SENSe]:POWer[:RF]:ATTenuation:STEP[:INCRement]	Set attenuator step
[:SENSe]:POWer[:RF]:ATTenuation:STEP[:INCRement]?	Query attenuator step
[:SENSe]:POWer[:RF]:EATTenuation <value>	Set electronic attenuator
[:SENSe]:POWer[:RF]:EATTenuation?	Query electronic attenuator
[:SENSe]:POWer[:RF]:EATTenuation:STATe ON OFF 1 0	Set electronic attenuator ON/OFF
[:SENSe]:POWer[:RF]:EATTenuation:STATe?	Query electronic attenuator ON/OFF
[:SENSe]:POWer[:RF]:GAIN[:STATe] ON OFF 1 0	Set gain ON/OFF
[:SENSe]:POWer[:RF]:GAIN[:STATe]?	Query gain ON/OFF
[:SENSe]:POWer[:RF]:MIXer:RANGe[:UPPer] <value>	Set the maximum mixer level
[:SENSe]:POWer[:RF]:MIXer:RANGe[:UPPer]?	Query maximum mixer level

**Annex B Zoom table of SCPI commands**

[;SENSe]:POWer[:RF]:MIXer:RULes NORMAl TOI COMPReSSion	Set maximum mixer level rule
[;SENSe]:POWer[:RF]:MIXer:RULes?	Query maximum mixer level rule

**Table 11 SCPI zoom table for spectrum emission mask**

Command	Function
:CONFigure:SEMask	Enter Measurement
:FETCh:SEMask<n>?	Query measurement results, trace, and mask trace data
:CALCulate:SEM:MARKer[1]2-12:MAXimum:LEFT	Set left adjacent peak
:CALCulate:SEMask:MARKer:AOFF	Mkr All Off
:CALCulate:SEMask:MARKer[1]2--12:MAXimum	Set peak
:CALCulate:SEMask:MARKer[1]2--12:MAXimum:NEXT	Set sub peak
:CALCulate:SEMask:MARKer[1]2--12:MAXimum:RIGHT	Set right adjacent peak
:CALCulate:SEMask:MARKer[1]2--12:MODE POSition  DELTA  FIXEd  OFF	Set the type for the marker
:CALCulate:SEMask:MARKer[1]2--12:MODE?	Query the type for the marker
:DISPlay:SEMask:WINDow[1]:TRACe:X:FLINe[1]2--6 <freq>	Set frequency display line value
:DISPlay:SEMask:WINDow[1]:TRACe:X:FLINe[1]2--6?	Query frequency display line value
:DISPlay:SEMask:SUBBlock[1]2--8:OFFSet[1]2--12:LIST:WINDow[1]:TRACe:Y[:SCALE]:RLEVel <ampl>	Set sub block offset channel reference level
:DISPlay:SEMask:SUBBlock[1]2--8:OFFSet[1]2--12:LIST:WINDow[1]:TRACe:Y[:SCALE]:RLEVel?	Query sub block offset channel reference level
:DISPlay:SEMask:SUBBlock[1]2--8:WINDow[1]:TRACe:Y[:SCALE]:RLEVel <ampl>	Set sub block reference channel reference level
:DISPlay:SEMask:SUBBlock[1]2--8:WINDow[1]:TRACe:Y[:SCALE]:RLEVel?	Query sub block reference channel reference level
:DISPlay:SEMask:WINDow[1]:TRACe:X:FLINe:STATe OFF ON 0 1	Set frequency display line ON/OFF
:DISPlay:SEMask:WINDow[1]:TRACe:X:FLINe:STATe?	Query frequency display line ON/OFF
:DISPlay:SEMask:WINDow[1]:TRACe:Y:DLINe[1]2--6 <ampl>	Set amplitude display line value
:DISPlay:SEMask:WINDow[1]:TRACe:Y:DLINe[1]2--6:STATe OFF ON 0 1	Set amplitude display line ON/OFF
:DISPlay:SEMask:WINDow[1]:TRACe:Y:DLINe[1]2--6:STATe?	Query amplitude display line ON/OFF
:DISPlay:SEMask:WINDow[1]:TRACe:Y:DLINe[1]2--6?	Query amplitude display line value
:DISPlay:SEMask:WINDow[1]:TRACe:Y:SPACing LINear LOGarithmic	SetAmplitudeScaleType
:DISPlay:SEMask:WINDow[1]:TRACe:Y:SPACing?	QueryAmplitudeScaleType
:DISPlay:SEMask:WINDow[1]:TRACe[1]:Y[:SCALE]:PDIVision <rel_ampl>	SetScalePDiv

## Annex B Zoom table of SCPI commands

:DISPlay:SEMask:WINDow[1]:TRACe[1]:Y[:SCALe]:PDIVision?	QueryScalePDiv
:INITiate:CONTInuous OFF ON 0 1	Setting sweep status
:INITiate:CONTInuous?	Query sweep state
:SEMask:SWEep:FFT:WIDTh <real>	Set FFT width
:SEMask:SWEep:FFT:WIDTh <real>?	Query FFT width
:SEMask:SWEep:FFT:WIDTh:AUTO OFF ON 0 1	Set FFT width Auto/Manual
:SEMask:SWEep:FFT:WIDTh:AUTO?	Query FFT width Auto/Manual
:SEMask:SWEep:TYPE:AUTO:RULes AUTO SPEEd DRANge	Set sweep type rule
:SEMask:SWEep:TYPE:AUTO:RULes?	Query sweep type rule
:TRACe:SEMask:TYPE AVERAge	Set Trace - Avgs
:TRACe:SEMask:TYPE WRITe	Set Trace - Refresh
:TRACe:SEMask:TYPE?	Query trace state
:UNIT:SEMask:POWer DBM DBM DBMA V W A DBUV DBUA	Set vertical axis units
:UNIT:SEMask:POWer?	Query vertical axis units
[[:SENSe]:SEMask:ADC:DITHer:AUTO[:STATe] OFF ON 0 1	Set ADC Dither Auto/Manual
[[:SENSe]:SEMask:ADC:DITHer:AUTO[:STATe]?	Query ADC Dither Auto/Manual
[[:SENSe]:SEMask:ADC:DITHer[:STATe] OFF ON HIGH	Set ADC Dither
[[:SENSe]:SEMask:ADC:DITHer[:STATe]?	Query ADC Dither
[[:SENSe]:AVERAge:COUNT <integer>	Set average times
[[:SENSe]:AVERAge:COUNT?	Query average times
[[:SENSe]:AVERAge:TYPE LOG   RMS   SCALAr	Set average type
[[:SENSe]:AVERAge:TYPE:AUTO OFF ON 0 1	Set Average Type Auto/Manual
[[:SENSe]:AVERAge:TYPE:AUTO?	Query Average Type Auto/Manual
[[:SENSe]:AVERAge:TYPE?	Query average type
[[:SENSe]:BANDwidth BWIDTh:SHAPE GAUSSian FLATtop	Set the filter type
[[:SENSe]:BANDwidth BWIDTh:SHAPE?	Query filter type
[[:SENSe]:DETEctor NORMAl   POSitive   SAMPlE   NEGAtive   AVERAge   RMS   SCALAr	Set detection mode
[[:SENSe]:DETEctor?	Query detector mode
[[:SENSe]:FREQuency:CENTer <frequency>	Set center frequency
[[:SENSe]:FREQuency:CENTer?	Query center frequency
[[:SENSe]:FREQuency:CENTer:STEP:AUTO OFF ON 0 1	Set Freq Step Auto/Man
[[:SENSe]:FREQuency:CENTer:STEP:AUTO?	Query Freq Step Auto/Man

## Annex B Zoom table of SCPI commands

[;SENSe]:FREQuency:CENTer:STEP[:INCRement] <freq>	Set the frequency step
[;SENSe]:FREQuency:CENTer:STEP[:INCRement]?	Query frequency step
[;SENSe]:FREQuency:OFFSet <freq>	Set frequency offset
[;SENSe]:FREQuency:OFFSet?	Query frequency offset
[;SENSe]:POWer[:RF]:EATTenuation <rel_power>	Set electronic attenuator
[;SENSe]:POWer[:RF]:EATTenuation:STATe OFF ON 0 1	Set electronic attenuator ON/OFF
[;SENSe]:POWer[:RF]:EATTenuation:STATe?	Query electronic attenuator ON/OFF
[;SENSe]:POWer[:RF]:EATTenuation?	Query electronic attenuator
[;SENSe]:POWer[:RF]:MIXer:RANGe[:UPPer] <ampl>	Set the maximum mixer level
[;SENSe]:POWer[:RF]:MIXer:RANGe[:UPPer]?	Query maximum mixer level
[;SENSe]:POWer[:RF]:MIXer:RULes NORMal TOI COMPression	Set maximum mixer level rule
[;SENSe]:POWer[:RF]:MIXer:RULes?	Query maximum mixer level rule
[;SENSe]:SEMAsk:ADJust:LEVel	Set auto scale
[;SENSe]:SEMAsk:SWEep:POINts <integer>	Set number of sweep points
[;SENSe]:SEMAsk:SWEep:POINts?	Query number of sweep points
[;SENSe]:SEMAsk:SWEep:TYPE	Query sweep type Auto/Manual
[;SENSe]:SEMAsk:SWEep:TYPE FFT SWEep	SetSwpType
[;SENSe]:SEMAsk:SWEep:TYPE?	QuerySwpType
[;SENSe]:SEMAsk:SWEep:TYPE:AUTO OFF ON 0 1	Set sweep type Auto/Manual
[;SENSe]:SEMAsk:SWEep:TYPE:AUTO?	Query sweep type Auto/Manual
[SENSe:]SEMAsk:SUBBlock[1] 2--8: BANDwidth:VIDeo <freq>	Set reference channel video bandwidth of sub-module
[SENSe:]SEMAsk:SUBBlock[1] 2--8: BANDwidth:VIDeo?	Query sub block reference channel video bandwidth
[SENSe:]SEMAsk:SUBBlock[1] 2--8: BANDwidth[:RESolution] <freq>	Set sub block reference channel resolution bandwidth
[SENSe:]SEMAsk:SUBBlock[1] 2--8: BANDwidth[:RESolution]?	Query sub block reference channel resolution bandwidth
[SENSe:]SEMAsk:SUBBlock[1] 2--8: FILTer[:RRC]:ALPHa <float>	Set sub block reference channel filter factor
[SENSe:]SEMAsk:SUBBlock[1] 2--8: FILTer[:RRC]:ALPHa?	Query sub block reference channel filter factor
[SENSe:]SEMAsk:SUBBlock[1] 2--8: FREQuency:CENTer <Frequency>	Set sub block reference channel center frequency
[SENSe:]SEMAsk:SUBBlock[1] 2--8: FREQuency:CENTer?	Query sub block reference channel center frequency
[SENSe:]SEMAsk:SUBBlock[1] 2--8: FREQuency:SPAN <freq>	Set reference channel bandwidth of sub-module
[SENSe:]SEMAsk:SUBBlock[1] 2--8: FREQuency:SPAN?	Query sub block reference channel bandwidth
[SENSe:]SEMAsk:SUBBlock[1] 2--8: OFFSet[1] 2--12: LIST: BANDwidth:VIDeo <freq>	Set sub block offset channel video bandwidth
[SENSe:]SEMAsk:SUBBlock[1] 2--8: OFFSet[1] 2--12: LIST: BANDwidth:VIDeo?	Query sub block offset channel video bandwidth

## Annex B Zoom table of SCPI commands

[SENSe:]SEMask:SUBBlock[1]2--8:OFFSet[1]2--12:LIST:BANDwidth[:RESolution] <freq>	Set sub block offset channel resolution bandwidth
[SENSe:]SEMask:SUBBlock[1]2--8:OFFSet[1]2--12:LIST:BANDwidth[:RESolution]?	Query sub block offset channel resolution bandwidth
[SENSe:]SEMask:SUBBlock[1]2--8:OFFSet[1]2--12:LIST:FREQuency:STARt <freq>	Set sub block offset channel start frequency
[SENSe:]SEMask:SUBBlock[1]2--8:OFFSet[1]2--12:LIST:FREQuency:STARt?	Query sub block offset channel start frequency
[SENSe:]SEMask:SUBBlock[1]2--8:OFFSet[1]2--12:LIST:FREQuency:STOP <freq>	Set sub block offset channel stop frequency
[SENSe:]SEMask:SUBBlock[1]2--8:OFFSet[1]2--12:LIST:FREQuency:STOP?	Query sub block offset channel stop frequency
[SENSe:]SEMask:SUBBlock[1]2--8:OFFSet[1]2--12:LIST:POWer[:RF]:ATTenuation <rel_power>	Set sub block offset channel attenuator
[SENSe:]SEMask:SUBBlock[1]2--8:OFFSet[1]2--12:LIST:POWer[:RF]:ATTenuation:AUTO OFF ON 0 1	Set sub block offset channel attenuator Auto/Manual
[SENSe:]SEMask:SUBBlock[1]2--8:OFFSet[1]2--12:LIST:POWer[:RF]:ATTenuation:AUTO?	Query sub block offset channel attenuator Auto/Manual
[SENSe:]SEMask:SUBBlock[1]2--8:OFFSet[1]2--12:LIST:POWer[:RF]:ATTenuation?	Query sub block offset channel attenuator
[SENSe:]SEMask:SUBBlock[1]2--8:OFFSet[1]2--12:LIST:POWer[:RF]:GAIN[:STATe] OFF ON 0 1	Set sub block offset channel preamplifier
[SENSe:]SEMask:SUBBlock[1]2--8:OFFSet[1]2--12:LIST:POWer[:RF]:GAIN[:STATe]?	Query sub block offset channel preamplifier
[SENSe:]SEMask:SUBBlock[1]2--8:OFFSet[1]2--12:LIST:STARt:ABSolute <ampl>	Set absolute start limit for sub block offset channel
[SENSe:]SEMask:SUBBlock[1]2--8:OFFSet[1]2--12:LIST:STARt:ABSolute?	Query absolute start limit for sub block offset channel
[SENSe:]SEMask:SUBBlock[1]2--8:OFFSet[1]2--12:LIST:STARt:RCA Rrier <rel_power>	Set relative start limit of sub block offset channel
[SENSe:]SEMask:SUBBlock[1]2--8:OFFSet[1]2--12:LIST:STARt:RCA Rrier?	Query relative start limit of sub block offset channel
[SENSe:]SEMask:SUBBlock[1]2--8:OFFSet[1]2--12:LIST:STOP:ABSolute <ampl>	Set absolute stop limit for sub block offset channel
[SENSe:]SEMask:SUBBlock[1]2--8:OFFSet[1]2--12:LIST:STOP:ABSolute?	Query absolute stop limit for sub block offset channel
[SENSe:]SEMask:SUBBlock[1]2--8:OFFSet[1]2--12:LIST:STOP:RCA Rrier <rel_power>	Set relative stop limit for sub block offset channel

## Annex B Zoom table of SCPI commands

[SENSe]:SEMAsk:SUBBlock[1]]2--8:OFFSet[1]]2--12:LIST:STOP:RCA Rrier?	Query relative stop limit for sub block offset channel
[SENSe]:SEMAsk:SUBBlock[1]]2--8:OFFSet[1]]2--12:LIST:SWEp:TIME <time>	Set sub block offset channel sweep time
[SENSe]:SEMAsk:SUBBlock[1]]2--8:OFFSet[1]]2--12:LIST:SWEp:TIME:AUTO OFF ON 0 1	Set sub block offset channel sweep time Auto/Manual
[SENSe]:SEMAsk:SUBBlock[1]]2--8:OFFSet[1]]2--12:LIST:SWEp:TIME:AUTO?	Query sub block offset channel sweep time Auto/Manual
[SENSe]:SEMAsk:SUBBlock[1]]2--8:OFFSet[1]]2--12:LIST:SWEp:TIME?	Query sub block offset channel sweep time
[SENSe]:SEMAsk:SUBBlock[1]]2--8:OFFSet[1]]2--12:LIST:TEST ABSolute AND OR RELative	Set Sub Block Offset Channel Limit Mask
[SENSe]:SEMAsk:SUBBlock[1]]2--8:OFFSet[1]]2--12:LIST:TEST?	Query Sub Block Offset Channel Limit Mask
[SENSe]:SEMAsk:SUBBlock[1]]2--8:OFFSet[1]]2--12:STATE OFF ON 0 1	Set sub block offset channel ON/OFF
[SENSe]:SEMAsk:SUBBlock[1]]2--8:OFFSet[1]]2--12:STATE?	Query sub block offset channel ON/OFF
[SENSe]:SEMAsk:SUBBlock[1]]2--8:POWEr:REFerence POWEr PEAK	Set sub block reference channel reference type
[SENSe]:SEMAsk:SUBBlock[1]]2--8:POWEr:REFerence?	Query sub block reference channel reference type
[SENSe]:SEMAsk:SUBBlock[1]]2--8:POWEr[:RF]:ATTenuation <rel_power>	Set sub block reference channel attenuator
[SENSe]:SEMAsk:SUBBlock[1]]2--8:POWEr[:RF]:ATTenuation:AUTO OFF ON 0 1	Set sub block reference channel attenuator Auto/Manual
[SENSe]:SEMAsk:SUBBlock[1]]2--8:POWEr[:RF]:ATTenuation:AUTO?	Query sub block reference channel attenuator Auto/Manual
[SENSe]:SEMAsk:SUBBlock[1]]2--8:POWEr[:RF]:ATTenuation?	Query sub block reference channel attenuator
[SENSe]:SEMAsk:SUBBlock[1]]2--8:POWEr[:RF]:GAIN[:STATE] OFF ON 0 1	Set sub block reference channel preamplifier
[SENSe]:SEMAsk:SUBBlock[1]]2--8:POWEr[:RF]:GAIN[:STATE]?	Query sub block reference channel preamplifier
[SENSe]:SEMAsk:SUBBlock[1]]2--8:SWEp:TIME <time>	Set sub block reference channel sweep time
[SENSe]:SEMAsk:SUBBlock[1]]2--8:SWEp:TIME:AUTO OFF ON 0 1	Set sub block reference channel sweep time Auto/Manual
[SENSe]:SEMAsk:SUBBlock[1]]2--8:SWEp:TIME:AUTO?	Query sub block reference channel sweep time Auto/Manual
[SENSe]:SEMAsk:SUBBlock[1]]2--8:SWEp:TIME?	Query sub block reference channel sweep time
SEMAsk:SUBBlock[1]]2--8:BANDwidth:INTEgration <freq>	Set reference channel integral bandwidth of sub-module
SEMAsk:SUBBlock[1]]2--8:BANDwidth:INTEgration?	Query sub block reference channel integral bandwidth
[;SENSe]:SWEp:EGATE:HOLDoff <time>	Set trigger OFF time
[;SENSe]:SWEp:EGATE:HOLDoff?	Query trigger block time
[;SENSe]:SWEp:EGATE:HOLDoff:AUTO OFF ON 0 1	Set trigger block ON/OFF

## Annex B Zoom table of SCPI commands

[:SENSe]:SWEep:EGATe:HOLDoff:AUTO?	Query trigger block ON/OFF
:TRIGger[:SEQuence]:EXTernal[1] 2 3:DELay <time>	Set trigger delay ON/OFF of External Trigger 1, External Trigger 2, and External Trigger 3
:TRIGger[:SEQuence]:EXTernal[1] 2 3:DELay?	Query trigger delay of External Trigger 1, External Trigger 2, and External Trigger 3
:TRIGger[:SEQuence]:EXTernal[1] 2 3:DELay:STATe OFF ON 0 1	Set trigger delay ON/OFF of External Trigger 1, External Trigger 2, and External Trigger 3
:TRIGger[:SEQuence]:EXTernal[1] 2 3:DELay:STATe?	Query trigger delay ON/OFF of External Trigger 1, External Trigger 2, and External Trigger 3
:TRIGger[:SEQuence]:EXTernal[1] 2:LEVel <level>	Set trigger level of External Trigger 1 or External Trigger 2
:TRIGger[:SEQuence]:EXTernal[1] 2:LEVel?	Query trigger level of External Trigger 1 or External Trigger 2
:TRIGger[:SEQuence]:EXTernal[1] 2 3:SLOPe POSitive NEGative	Set the Trigger Slope of External Trigger 1, External Trigger 2, and External Trigger 3
:TRIGger[:SEQuence]:EXTernal[1] 2 3:SLOPe?	Query the Trigger Slope of External Trigger 1, External Trigger 2, and External Trigger 3
:TRIGger[:SEQuence]:FRAMe:DELay <time>	Set Time Trigger delay
:TRIGger[:SEQuence]:FRAMe:DELay?	Query Time Trigger delay
:TRIGger[:SEQuence]:FRAMe:DELay:STATe OFF ON 0 1	Set Trigger Delay ON/OFF of Trigger Timer
:TRIGger[:SEQuence]:FRAMe:DELay:STATe?	Query Trigger Delay ON/OFF of Trigger Timer
:TRIGger[:SEQuence]:FRAMe:OFFSet <time>	Set Time Trigger Offset
:TRIGger[:SEQuence]:FRAMe:OFFSet?	Query Time Trigger Offset
:TRIGger[:SEQuence]:FRAMe:PERiod <time>	Set Time Trigger Cycle
:TRIGger[:SEQuence]:FRAMe:PERiod?	Query Time Trigger Cycle
:TRIGger[:SEQuence]:FRAMe:SYNC EXTernal1 EXTernal2 RFBurst OFF	Sync Source Selection
:TRIGger[:SEQuence]:FRAMe:SYNC?	Query Synchronization Source Selection
:TRIGger[:SEQuence]:FRAMe:SYNC:HOLDoff <time>	Set synchronization source blocking
:TRIGger[:SEQuence]:FRAMe:SYNC:HOLDoff?	Query synchronization source blocking
:TRIGger[:SEQuence]:LINE:DELay <time>	Set power trigger delay
:TRIGger[:SEQuence]:LINE:DELay?	Query power trigger delay
:TRIGger[:SEQuence]:LINE:DELay:STATe OFF ON 0 1	Set power trigger delay ON/OFF
:TRIGger[:SEQuence]:LINE:DELay:STATe?	Query power trigger delay ON/OFF
:TRIGger[:SEQuence]:LINE:SLOPe POSitive NEGative	Set Power Trigger Slope
:TRIGger[:SEQuence]:LINE:SLOPe?	Query Power Trigger Slope
:TRIGger[:SEQuence]:RFBurst:DELay <time>	Set trigger delay of burst signal

**Annex B Zoom table of SCPI commands**

:TRIGger[:SEquence]:RFBurst:DElay?	Query trigger delay of burst signal
:TRIGger[:SEquence]:RFBurst:DElay:STATe OFF ON 0 1	Set trigger delay ON/OFF of burst signal
:TRIGger[:SEquence]:RFBurst:DElay:STATe?	Query trigger delay ON/OFF of burst signal
:TRIGger[:SEquence]:RFBurst:LEVel:ABSolute <ampl>	Set burst signal trigger level
:TRIGger[:SEquence]:RFBurst:LEVel:ABSolute?	Query burst signal trigger level
:TRIGger[:SEquence]:RFBurst:SLOPe POSitive NEGative	Set Trigger Slope of Burst Signal Trigger
:TRIGger[:SEquence]:RFBurst:SLOPe?	Query Trigger Slope of Burst Signal Trigger
:TRIGger[:SEquence]:SOURce EXTernal1 EXTernal2 EXTernal3 IMMediate LINE FRAME RFBurst VIDeo	Trigger Mode Selection
:TRIGger[:SEquence]:SOURce?	Query Trigger Mode Selection
:TRIGger[:SEquence]:VIDeo:DElay <time>	Set video trigger delay
:TRIGger[:SEquence]:VIDeo:DElay?	Query video trigger delay
:TRIGger[:SEquence]:VIDeo:DElay:STATe OFF ON 0 1	Set video trigger delay
:TRIGger[:SEquence]:VIDeo:DElay:STATe?	Query video trigger delay
:TRIGger[:SEquence]:VIDeo:LEVel <ampl>	Set video trigger level
:TRIGger[:SEquence]:VIDeo:LEVel?	Query video trigger level
:TRIGger[:SEquence]:VIDeo:SLOPe POSitive NEGative	Set Video Trigger Slope
:TRIGger[:SEquence]:VIDeo:SLOPe?	Query Video Trigger Slope

**Table 12 Zoom table of IQ analysis SCIP commands**

Command	Function
:CALCulate[1]2--6:DELTaMarker[1]2--12:AOff	Turn off all delta markers
:CALCulate[1]2--6:DELTaMarker[1]2--12:FUNCTion:BPOWer:MODE POWer DENsity	Delta Marker Bandwidth Power Mode
:CALCulate[1]2--6:DELTaMarker[1]2--12:FUNCTion:BPOWer:MODE ?	Delta Marker Bandwidth Power Mode
:CALCulate[1]2--6:DELTaMarker[1]2--12:FUNCTion:BPOWer:RESult ?	Delta Marker Bandwidth Power Result
:CALCulate[1]2--6:DELTaMarker[1]2--12:FUNCTion:BPOWer:SPAN <freq>	Delta Marker Bandwidth Power Bandwidth Span
:CALCulate[1]2--6:DELTaMarker[1]2--12:FUNCTion:BPOWer:SPAN?	Delta Marker Bandwidth Power Bandwidth Span
:CALCulate[1]2--6:DELTaMarker[1]2--12:FUNCTion:BPOWer[:STATe] OFF ON 0 1	Delta Marker Bandwidth Power State
:CALCulate[1]2--6:DELTaMarker[1]2--12:FUNCTion:BPOWer[:STATe] ?	Delta Marker Bandwidth Power State

## Annex B Zoom table of SCPI commands

:CALCulate[1]2--6:DELTamarker[1]2--12:LINK OFF ON 0 1	Delta marker association
:CALCulate[1]2--6:DELTamarker[1]2--12:LINK?	Delta marker association
:CALCulate[1]2--6:DELTamarker[1]2--12:LINK:TO:MARKer[1]2--12 OFF ON 0 1	Delta Marker Associated to Marker 1
:CALCulate[1]2--6:DELTamarker[1]2--12:LINK:TO:MARKer[1]2--12 ?	Delta Marker Associated to Marker 1
:CALCulate[1]2--6:DELTamarker[1]2--12:MAXimum:AUTO OFF ON 0 1	Delta Marker Continuous Peak Search
:CALCulate[1]2--6:DELTamarker[1]2--12:MAXimum:AUTO?	Delta Marker Continuous Peak Search
:CALCulate[1]2--6:DELTamarker[1]2--12:MAXimum:LEFT	Delta Marker Left Neighbor Peak Search
:CALCulate[1]2--6:DELTamarker[1]2--12:MAXimum:NEXT	Delta Marker Sub Peak Search
:CALCulate[1]2--6:DELTamarker[1]2--12:MAXimum:RIGHT	Delta Marker Right Neighbor Peak Search
:CALCulate[1]2--6:DELTamarker[1]2--12:MAXimum[:PEAK]	Delta Marker Peak Search
:CALCulate[1]2--6:DELTamarker[1]2--12:MREFerence 1 2 3 4 5 6 7 8 9 10 11 12	Delta Marker Reference Selection
:CALCulate[1]2--6:DELTamarker[1]2--12:MREFerence?	Delta Marker Reference Selection
:CALCulate[1]2--6:DELTamarker[1]2--12:SPECTrogram:FRAME <Frame>	Marker Z (waterfall plot frame selection)
:CALCulate[1]2--6:DELTamarker[1]2--12:SPECTrogram:FRAME?	Marker Z (waterfall plot frame selection)
:CALCulate[1]2--6:DELTamarker[1]2--12:TRACe TRACE1 TRACE2 TRACE3 TRACE4 TRACE5 TRACE6	Delta marker trace
:CALCulate[1]2--6:DELTamarker[1]2--12:TRACe?	Delta marker trace
:CALCulate[1]2--6:DELTamarker[1]2--12:X <value>	Delta marker horizontal axis
:CALCulate[1]2--6:DELTamarker[1]2--12:X?	Delta marker horizontal axis
:CALCulate[1]2--6:DELTamarker[1]2--12:X:RELative <value>	Delta Marker Horizontal Axis Relative
:CALCulate[1]2--6:DELTamarker[1]2--12:X:RELative?	Delta Marker Horizontal Axis Relative
:CALCulate[1]2--6:DELTamarker[1]2--12:Y <value>	Delta Marker Y-axis Value
:CALCulate[1]2--6:DELTamarker[1]2--12:Y?	Delta Marker Y-axis Value
:CALCulate[1]2--6:DELTamarker[1]2--12[:STATe] OFF ON 0 1	Delta marker state
:CALCulate[1]2--6:DELTamarker[1]2--12[:STATe]?	Delta marker state
:CALCulate[1]2--6:MARKer[1]2--12:AOFF	All Mkr OFF
:CALCulate[1]2--6:MARKer[1]2--12:FUNCTION:BPOWER:AOFF	Turn Off All Bandwidth Power Markers
:CALCulate[1]2--6:MARKer[1]2--12:FUNCTION:BPOWER:MODE POWER DENSity	Delta Marker Bandwidth Power Mode
:CALCulate[1]2--6:MARKer[1]2--12:FUNCTION:BPOWER:MODE?	Delta Marker Bandwidth Power Mode

## Annex B Zoom table of SCPI commands

:CALCulate[1]2--6:MARKer[1]2--12:FUNction:BPOWer:RESult?	Delta Marker Bandwidth Power Result
:CALCulate[1]2--6:MARKer[1]2--12:FUNction:BPOWer:SPAN<Freq >	Delta Marker Bandwidth Power Bandwidth Span
:CALCulate[1]2--6:MARKer[1]2--12:FUNction:BPOWer:SPAN?	Delta Marker Bandwidth Power Bandwidth Span
:CALCulate[1]2--6:MARKer[1]2--12:FUNction:BPOWer[:STATe] OFF ON 0 1	Delta Marker Bandwidth Power State
:CALCulate[1]2--6:MARKer[1]2--12:FUNction:BPOWer[:STATe]?	Delta Marker Bandwidth Power State
:CALCulate[1]2--6:MARKer[1]2--12:FUNction:CENTer	Marker → Center
:CALCulate[1]2--6:MARKer[1]2--12:FUNction:REFerence	Marker → Ref
:CALCulate[1]2--6:MARKer[1]2--12:LINK:TO:MARKer[1]2--12 OFF ON 0 1	Marker Associated to Marker 1
:CALCulate[1]2--6:MARKer[1]2--12:LINK:TO:MARKer[1]2--12?	Marker Associated to Marker 1
:CALCulate[1]2--6:MARKer[1]2--12:MAXimum:AUTO OFF ON 0 1	Marker Continuous Peak Search
:CALCulate[1]2--6:MARKer[1]2--12:MAXimum:AUTO?	Marker Continuous Peak Search
:CALCulate[1]2--6:MARKer[1]2--12:MAXimum:LEFT	Mark the left adjacent peak search
:CALCulate[1]2--6:MARKer[1]2--12:MAXimum:NEXT	Mark the sub-peak search
:CALCulate[1]2--6:MARKer[1]2--12:MAXimum:RIGHT	Mark the right adjacent peak search
:CALCulate[1]2--6:MARKer[1]2--12:MAXimum[:PEAK]	Mark peak search
:CALCulate[1]2--6:MARKer[1]2--12:MINimum[:PEAK]	Mark the min. value search
:CALCulate[1]2--6:MARKer[1]2--12:PEXCursion <amp;>	Peak Definition Value
:CALCulate[1]2--6:MARKer[1]2--12:PEXCursion?	Peak Definition Value
:CALCulate[1]2--6:MARKer[1]2--12:SPECTrogram:FRAME <Frame>	Marker Z (waterfall plot frame selection)
:CALCulate[1]2--6:MARKer[1]2--12:SPECTrogram:FRAME?	Marker Z (waterfall plot frame selection)
:CALCulate[1]2--6:MARKer[1]2--12:TRACe TRACE1 TRACE2 TRACE3 TRACE4 TRACE5 TRACE6	Marker Trace
:CALCulate[1]2--6:MARKer[1]2--12:TRACe?	Marker Trace
:CALCulate[1]2--6:MARKer[1]2--12:X <value>	Marker Horizontal Axis
:CALCulate[1]2--6:MARKer[1]2--12:X?	Marker Horizontal Axis
:CALCulate[1]2--6:MARKer[1]2--12:Y <value>	Marker Y-axis Value
:CALCulate[1]2--6:MARKer[1]2--12:Y?	Marker Y-axis Value
:CALCulate[1]2--6:MARKer[1]2--12[:STATe] OFF ON 0 1	Marker State
:CALCulate[1]2--6:MARKer[1]2--12[:STATe]?	Marker State
:CALCulate[1]2--6:SGRam:CLEar[:IMMEdiate]	Clear Waterfall Plot
:CALCulate[1]2--6:SGRam:FRAME:SElect <Frame>	Marker Z (waterfall plot frame selection)

## Annex B Zoom table of SCPI commands

:CALCulate[1]2--6:SGRam:FRAME:SElect?	Marker Z (waterfall plot frame selection)
:CALCulate[1]2--6:SGRam:HDEPth <Frame>	Waterfall Plot Storage Depth
:CALCulate[1]2--6:SGRam:HDEPth?	Waterfall Plot Storage Depth
:CALCulate[1]2--6:SGRam:TRACe TRACE1 TRACE2 TRACE3 TRACE4 TRACE5 TRACE6	Waterfall Plot Trace
:CALCulate[1]2--6:SGRam:TRACe?	Waterfall Plot Trace
:CALCulate[1]2--6:SGRam[:STATe] OFF ON 0 1	Waterfall Plot State
:CALCulate[1]2--6:SGRam[:STATe]?	Waterfall Plot State
:CALCulate[1]2--6:SPECTrogram:CLEar[:IMMediate]	Clear Waterfall Plot
:CALCulate[1]2--6:SPECTrogram:FRAME:COUNT <Frame>	Waterfall Plot Single Measurement Frames
:CALCulate[1]2--6:SPECTrogram:FRAME:COUNT?	Waterfall Plot Single Measurement Frames
:CALCulate[1]2--6:SPECTrogram:FRAME:SElect <Frame>	Marker Z (waterfall plot frame selection)
:CALCulate[1]2--6:SPECTrogram:FRAME:SElect?	Marker Z (waterfall plot frame selection)
:CALCulate[1]2--6:SPECTrogram:HDEPth <Frame>	Waterfall Plot Storage Depth
:CALCulate[1]2--6:SPECTrogram:HDEPth?	Waterfall Plot Storage Depth
:CALCulate[1]2--6:SPECTrogram:TRACe TRACE1 TRACE2 TRACE3 TRACE4 TRACE5 TRACE6	Waterfall Plot Trace
:CALCulate[1]2--6:SPECTrogram:TRACe?	Waterfall Plot Trace
:CALCulate[1]2--6:SPECTrogram[:STATe] OFF ON 0 1	Waterfall Plot State
:CALCulate[1]2--6:SPECTrogram[:STATe]?	Waterfall Plot State
:CALCulate[1]2--6:THReshold <Value>	Peak Threshold Value
:CALCulate[1]2--6:THReshold?	Peak Threshold Value
:CALCulate[1]2--6:THReshold:STATE OFF ON 0 1	Peak Threshold ON/OFF
:CALCulate[1]2--6:THReshold:STATE?	Peak Threshold ON/OFF
:DISPlay[:WINDow[1]2--6]:MINFo[:STATe] OFF ON 0 1	Marker Information Display
:DISPlay[:WINDow[1]2--6]:MINFo[:STATe]?	Marker Information Display
:DISPlay[:WINDow[1]2--6]:MTABLE OFF ON 0 1	Marker Report
:DISPlay[:WINDow[1]2--6]:MTABLE?	Marker Report
:DISPlay[:WINDow[1]2--6]:TRACe[1]2--6:MODE WRITE AVERAge MAXHold MINHold VIEW BLANK	Marker Type
:DISPlay[:WINDow[1]2--6]:TRACe[1]2--6:MODE?	Marker Type
:DISPlay[:WINDow[1]2--6]:TRACe[1]2--6:Y[:SCALE] <value>	Reference Value
:DISPlay[:WINDow[1]2--6]:TRACe[1]2--6:Y[:SCALE]?	Reference Value
:DISPlay[:WINDow[1]2--6]:TRACe[1]2--6:Y[:SCALE]:AUTO ONCE	Auto Scaling

**Annex B Zoom table of SCPI commands**

:DISPlay[:WINDow[1]]2--6:TRACe[1]]2--6:Y[:SCALe]:PDIVision <value>	SC/RAS
:DISPlay[:WINDow[1]]2--6:TRACe[1]]2--6:Y[:SCALe]:PDIVision?	SC/RAS
:DISPlay[:WINDow[1]]2--6:TRACe[1]]2--6:Y[:SCALe]:RLEVel <value>	Ref Level
:DISPlay[:WINDow[1]]2--6:TRACe[1]]2--6:Y[:SCALe]:RLEVel?	Ref Level
:DISPlay[:WINDow[1]]2--6:TRACe[1]]2--6:Y[:SCALe]:RLEVel:OFFSet <value>	Ref level offset
:DISPlay[:WINDow[1]]2--6:TRACe[1]]2--6:Y[:SCALe]:RLEVel:OFFSet ?	Ref level offset
:DISPlay[:WINDow[1]]2--6:TRACe[1]]2--6:Y[:SCALe]:RPOStion UP Mid Down	Reference Position
:DISPlay[:WINDow[1]]2--6:TRACe[1]]2--6:Y[:SCALe]:RPOStion?	Reference Position
:DISPlay[:WINDow[1]]2--6:TRACe[1]]2--6:Y:SPACing LOGarithmic LINear	Scale type
:DISPlay[:WINDow[1]]2--6:TRACe[1]]2--6:Y:SPACing?	Scale type
:INITiate[1]]2--6:CONTInuous OFF ON 0 1	Measurement mode
:INITiate[1]]2--6:CONTInuous?	Measurement mode
:INITiate[1]]2--6[:IMMediate]	Single measurement
:INPut[1]]2:ATTenuation <value>	Mechanical Attenuator Value
:INPut[1]]2:ATTenuation?	Mechanical Attenuator Value
:INPut[1]]2:ATTenuation:AUTO OFF ON 0 1	Mechanical anttenuator Auto/Manual
:INPut[1]]2:ATTenuation:AUTO?	Mechanical anttenuator Auto/Manual
:INPut[1]]2:ATTenuation:AUTO:MODE 2dB 10dB	Mechanical Attenuator Mode
:INPut[1]]2:ATTenuation:AUTO:MODE?	Mechanical Attenuator Mode
:INPut[1]]2:EATT <value>	Electronic Attenuator Value
:INPut[1]]2:EATT?	Electronic Attenuator Value
:INPut[1]]2:EATT:STATe OFF ON 0 1	Electronic Attenuator ON/OFF
:INPut[1]]2:EATT:STATe?	Electronic Attenuator ON/OFF
:INPut[1]]2:GAIN:STATe OFF ON 0 1	Preamplifier ON/OFF
:INPut[1]]2:GAIN:STATe	Preamplifier ON/OFF
:LAYout:ADD[:WINDow] FREQ MAGN RIMAG VECT	Create a New Spectrogram
:LAYout:CATalog[:WINDow]?	Query window information
:LAYout:IDENTify[:WINDow]?	Query window name
:LAYout:REMOve[:WINDow] <Name>	Window OFF
:LAYout:WINDow[1]]2--6:ADD FREQ MAGN RIMAG VECT	Add Window

## Annex B Zoom table of SCPI commands

:LAYout:WINDow[1] 2--6:IDentify?	Query window name
:LAYout:WINDow[1] 2--6:REMove	Window OFF
:TRACe:IQ:BWIDth <value>	Measurement Bandwidth
:TRACe:IQ:BWIDth	Measurement Bandwidth
:TRACe:IQ:DATA?	IQ data acquisition (single, waiting, data retrieval)
:TRACe:IQ:DATA:FORMat COMPAtible IQBlock IQPair	IQ data format
:TRACe:IQ:DATA:FORMat	IQ data format
:TRACe:IQ:DATA:MEMory?	IQ data acquisition
:TRACe:IQ:EVL	IQ data analysis
:TRACe:IQ:EVL?	IQ data analysis
:TRACe:IQ:RENgth <value>	Measured length
:TRACe:IQ:RENgth?	Measured length
:TRACe:IQ:SET <SampleRate, Length>	Measurement parameter set
:TRACe:IQ:SRATe <value>	Sampling rate
:TRACe:IQ:SRATe?	Sampling rate
:TRACe[1] 2--6[:DATA]? TRACE1 TRACE2 TRACE3 TRACE4 TRACE5 TRACE6 SPECTrogram SGR am	Measurement results: trace data, peak list, waterfall plot, etc
:TRIGger[:SEQuence]:HOLDoff[:TIME] <Time>	Trigger delay time
:TRIGger[:SEQuence]:HOLDoff[:TIME]?	Trigger delay time
:TRIGger[:SEQuence]:IFPower:HOLDoff <Time>	Trigger Blocking
:TRIGger[:SEQuence]:IFPower:HOLDoff?	Trigger Blocking
:TRIGger[:SEQuence]:LEVel:IFPower <Level>	Trigger Level (Power Trigger)
:TRIGger[:SEQuence]:LEVel:IFPower?	Trigger Level (Power Trigger)
:TRIGger[:SEQuence]:LEVel:RFPower <Level>	Trigger Level (Burst Trigger)
:TRIGger[:SEQuence]:LEVel:RFPower?	Trigger Level (Burst Trigger)
:TRIGger[:SEQuence]:LEVel[:EXTErnal[1] 2--3] <Level>	Trigger Level (External Trigger 1, 2 & 3)
:TRIGger[:SEQuence]:LEVel[:EXTErnal[1] 2--3]?	Trigger Level (External Trigger 1, 2 & 3)
:TRIGger[:SEQuence]:SLOPe POSitive NEGative	Trigger polarity
:TRIGger[:SEQuence]:SLOPe?	Trigger polarity
:TRIGger[:SEQuence]:SOURce IMMEDIATE EXTErnal[1]  EXTErnal[2]  EXTErnal[3]  RFPower TIME VIDeo	Trigger mode
:TRIGger[:SEQuence]:SOURce?	Trigger mode
:TRIGger[:SEQuence]:TIME:RINTErnal <Time>	Cycle (cycle Time Trigger)

**Annex B Zoom table of SCPI commands**

:TRIGger[:SEquence]:TIME:RINterval?	Cycle (cycle Time Trigger)
[:SENSe[1]][2--6]:SWEep:TIME <Time>	Measurement time
[:SENSe[1]][2--6]:SWEep:TIME?	Measurement time
[:SENSe[1]][2--6]:SWEep:TIME:AUTO OFF ON 0 1	Measurement Time Auto State
[:SENSe[1]][2--6]:SWEep:TIME:AUTO?	Measurement Time Auto State
[:SENSe]:ADJust:FREQuency	Auto Frequency
[:SENSe]:ADJust:LEVel	Auto Amplitude
[:SENSe]:AVERAge[1]][2--6]:TYPE VIDEo LINear POWER	Average/hold mode
[:SENSe]:AVERAge[1]][2--6]:TYPE?	Average/hold mode
[:SENSe]:AVERAge[1]][2--6]:TYPE:AUTO OFF ON 0 1	Average/Hold State
[:SENSe]:AVERAge[1]][2--6]:TYPE:AUTO?	Average/Hold State
[:SENSe]:FREQuency:CENTer <Freq>	Center frequency
[:SENSe]:FREQuency:CENTer?	Center frequency
[:SENSe]:FREQuency:CENTer:STEP <Freq>	Frequency Step
[:SENSe]:FREQuency:CENTer:STEP?	Frequency Step
[:SENSe]:FREQuency:CENTer:STEP:AUTO OFF ON 0 1	Freq Step Auto/Man
[:SENSe]:FREQuency:CENTer:STEP:AUTO?	Freq Step Auto/Man
[:SENSe]:FREQuency:STARt <Freq>	Start Freq
[:SENSe]:FREQuency:STARt?	Start Freq
[:SENSe]:FREQuency:STOP <Freq>	Stop Freq
[:SENSe]:FREQuency:STOP?	Stop Freq
[:SENSe]:IQ:BANDwidth:MODE AUTO MANual FFT	RBW mode
[:SENSe]:IQ:BANDwidth:MODE?	RBW mode
[:SENSe]:IQ:BANDwidth:RESolution <Rbw>	RBW
[:SENSe]:IQ:BANDwidth:RESolution?	RBW
[:SENSe]:IQ:BWIDth:MODE AUTO MANual FFT	RBW mode
[:SENSe]:IQ:BWIDth:MODE?	RBW mode
[:SENSe]:IQ:BWIDth:RESolution <Rbw>	RBW
[:SENSe]:IQ:BWIDth:RESolution?	RBW
[:SENSe]:IQ:FFT:ALGorithm SINGLE AVERAge	FFT Calculation Method
[:SENSe]:IQ:FFT:ALGorithm?	FFT Calculation Method
[:SENSe]:IQ:FFT:LENGth <value>	FFT Length
[:SENSe]:IQ:FFT:LENGth?	FFT Length

## Annex B Zoom table of SCPI commands

[[:SENSe]:IQ:FFT:WINDow:LENGth <value>	FFT Window Length
[[:SENSe]:IQ:FFT:WINDow:LENGth?	FFT Window Length
[[:SENSe]:IQ:FFT:WINDow:OVERlap <value>	FFT Window Overlap Rate
[[:SENSe]:IQ:FFT:WINDow:OVERlap?	FFT Window Overlap Rate
[[:SENSe]:IQ:FFT:WINDow:TYPE FLATtop GAUSS RECTangular KAISer BLANKmanharris	FFT Window Type
[[:SENSe]:IQ:FFT:WINDow:TYPE?	FFT Window Type
[[:SENSe]:POWer[:RF]:MIXer:RANGe[:UPPer] <value>	Maximum Mixer Level
[[:SENSe]:POWer[:RF]:MIXer:RANGe[:UPPer]?	Maximum Mixer Level
[[:SENSe]:SWAPiq OFF ON 0 1	IQ Data Exchange
[[:SENSe]:SWAPiq?	IQ Data Exchange
[[:SENSe]:SWEep[:WINDow[1]]2--6[:POINts] <value>	Sweep Points
[[:SENSe]:SWEep[:WINDow[1]]2--6[:POINts]?	Sweep Points
[[:SENSe][:WINDow[1]]2--6[:DETector[1]]2--6[:FUNction] APEak NEGative POSitive SAMPle RMS AVERage	Detector Mode
[[:SENSe][:WINDow[1]]2--6[:DETector[1]]2--6[:FUNction]?	Detector Mode
[[:SENSe][:WINDow[1]]2--6[:DETector[1]]2--6[:FUNction]:AUTO OFF ON 0 1	Detection mode (ON/OFF)
[[:SENSe][:WINDow[1]]2--6[:DETector[1]]2--6[:FUNction]:AUTO?	Detection mode (ON/OFF)

Table 13 SCPI zoom table for phase noise testing

Command	Function
:CALCulate:LPLot:MARKer:AOff	Mkr All Off
:CALCulate:LPLot:MARKer[1 2 3 4 5 6 7 8 9 10 11 12]:BAND:LEFT <freq>	Set bandwidth start position for marker function
:CALCulate:LPLot:MARKer[1 2 3 4 5 6 7 8 9 10 11 12]:BAND:LEFT?	Query bandwidth start position for marker function
:CALCulate:LPLot:MARKer[1 2 3 4 5 6 7 8 9 10 11 12]:BAND:RIGHT <freq>	Set bandwidth stop position for marker function
:CALCulate:LPLot:MARKer[1 2 3 4 5 6 7 8 9 10 11 12]:BAND:RIGHT?	Query bandwidth stop position for marker function
:CALCulate:LPLot:MARKer[1 2 3 4 5 6 7 8 9 10 11 12]:BAND:SPAN <freq>	Set bandwidth span for marker function
:CALCulate:LPLot:MARKer[1 2 3 4 5 6 7 8 9 10 11 12]:BAND:SPAN?	Query bandwidth span for marker function
:CALCulate:LPLot:MARKer[1 2 3 4 5 6 7 8 9 10 11 12]:FUNction OFF RADian DEGRee SSBJITter RFM RMSNoise	Select marker function type
:CALCulate:LPLot:MARKer[1 2 3 4 5 6 7 8 9 10 11 12]:FUNction?	Query current marker function type

## Annex B Zoom table of SCPI commands

:CALCulate:LPLot:MARKer[1 2 3 4 5 6 7 8 9 10 11 12]:MODE POSITION DELTA OFF	Set the type for the marker
:CALCulate:LPLot:MARKer[1 2 3 4 5 6 7 8 9 10 11 12]:MODE?	Query the type for the marker
:CALCulate:LPLot:MARKer[1 2 3 4 5 6 7 8 9 10 11 12]:REFERENCE <integer>	Set reference markers for markers
:CALCulate:LPLot:MARKer[1 2 3 4 5 6 7 8 9 10 11 12]:REFERENCE?	Query reference marker for the marker
:CALCulate:LPLot:MARKer[1 2 3 4 5 6 7 8 9 10 11 12]:TRACE <integer>	Select the trace where the marker is located
:CALCulate:LPLot:MARKer[1 2 3 4 5 6 7 8 9 10 11 12]:TRACE?	Query the trace where the marker is located
:CALCulate:LPLot:MARKer[1 2 3 4 5 6 7 8 9 10 11 12]:X <freq>	Set X-axis frequency of the marker
:CALCulate:LPLot:MARKer[1 2 3 4 5 6 7 8 9 10 11 12]:X?	Query X-axis frequency of the marker
:CALCulate:LPLot:MARKer[1 2 3 4 5 6 7 8 9 10 11 12]:Y?	Query the value of marker axis Y
:CALCulate:LPLot:MARKer[1 2 3 4 5 6 7 8 9 10 11 12]:SPURious:MAXi mum[:PEAK]	Search for spurious peak
:CALCulate:LPLot:MARKer[1 2 3 4 5 6 7 8 9 10 11 12]:SPURious:MAXi mum:NEXT	Search for spurious sub peak
:CALCulate:LPLot:MARKer[1 2 3 4 5 6 7 8 9 10 11 12]:SPURious:MAXi mum:RIGHT	Search for spurious right peak
:CALCulate:LPLot:MARKer[1 2 3 4 5 6 7 8 9 10 11 12]:SPURious:MAXi mum:LEFT	Search for spurious left peak
:CALCulate:MARKer[1 2 3 4 5 6 7 8 9 10 11 12]:MINimum	Spurious Minimum Search
:DISPlay:LPLot:VIEW:WINDOW:TRACE:Y[:SCALE]:PDIVision <rel_ampl>	Set amplitude scale
:DISPlay:LPLot:VIEW:WINDOW:TRACE:Y[:SCALE]:PDIVision?	Query amplitude scale
:DISPlay:LPLot:VIEW:WINDOW:TRACE:Y[:SCALE]:RLEVEL <real>	Setting reference values
:DISPlay:LPLot:VIEW:WINDOW:TRACE:Y[:SCALE]:RLEVEL?	Query reference value
:INITiate:CONTInuous ON OFF 1 0	Perform continuous single switching of measurements
:INITiate:CONTInuous?	Query whether it is a continuous measurement
:INITiate:PAUSE	Pause measurement
:INITiate:REStart	Restart
:INITiate:RESume	Resume measurement
:FETCh:LPLot[n]?	Get measurement results
:MEASure:LPLot[n]?	Perform logarithmic curve measurement and obtain measurement results
:READ:LPLot[n]?	Read measurement results
[:SENSe]:BANDwidth BWIDth[:RESolution]:RATio <Ratio>	Set resolution bandwidth ratio

## Annex B Zoom table of SCPI commands

[:SENSe]:BANDwidth BWIDth[:RESolution]:RATio?	Query RBW ratio
[:SENSe]:DEFaults	Reset to default state
[:SENSe]:FREQuency:CARRier <freq>	Set carrier frequency
[:SENSe]:FREQuency:CARRier?	Query carrier wave frequency
[:SENSe]:FREQuency:CARRier:SEARch	Perform carrier search
[:SENSe]:FREQuency:CARRier:SEARch:SPAN <freq>	Set carrier search span
[:SENSe]:FREQuency:CARRier:SEARch:SPAN?	Query carrier search span
[:SENSe]:FREQuency:CARRier:TRACk:ACCuracy LOW MED HIGH	Set signal tracking accuracy
[:SENSe]:FREQuency:CARRier:TRACk:ACCuracy?	Query signal tracking accuracy
[:SENSe]:FREQuency:CARRier:TRACk:SPAN <freq>	Set signal tracking span
[:SENSe]:FREQuency:CARRier:TRACk:SPAN?	Query signal tracking span
[:SENSe]:FREQuency:CARRier:TRACk[:STATe] ON OFF 1 0	Set signal tracking ON/OFF
[:SENSe]:FREQuency:CARRier:TRACk[:STATe]?	Query signal tracking ON/OFF
[:SENSe]:LPLot:AVERage:COUNT <integer>	Set average times
[:SENSe]:LPLot:AVERage:COUNT?	Query average times
[:SENSe]:LPLot:AVERage[:STATe] ON OFF 1 0	SetAvgOn
[:SENSe]:LPLot:AVERage[:STATe]?	QueryAvgOn
[:SENSe]:LPLot:FREQuency:OFFSet:STARt <freq>	Set start frequency offset
[:SENSe]:LPLot:FREQuency:OFFSet:STARt?	Query start frequency offset
[:SENSe]:LPLot:FREQuency:OFFSet:STOP <freq>	Set stop frequency offset
[:SENSe]:LPLot:FREQuency:OFFSet:STOP?	Query stop frequency offset
[:SENSe]:LPLot:METHod DAN PN	SetMeasTarget
[:SENSe]:LPLot:METHod?	QueryMeasTarget
[:SENSe]:LPLot:SMOoth <real>	Set smoothness
[:SENSe]:LPLot:SMOoth ?	Query smoothness
[:SENSe]:SPURs:SUPPression ON OFF 1 0	Set spurious suppression switch
[:SENSe]:SPURs:SUPPression ?	Query spurious suppression switch
[:SENSe]:SPURs:THReshold <Threshold>	Set spurious suppression threshold
[:SENSe]:SPURs:THReshold?	Query spurious suppression threshold
:TRACe[1 2 3]:LPLot:TYPE RAW SMOothed VIEW BLANK	Set trace type
:TRACe[1 2 3]:LPLot:TYPE?	Query trace type

Table 14 SCPI zoom table for WLAN signal analysis

Command	Function
:CALCulate:EVM:EQUalizer:TMODe SEQuence SDATa	Set equalization method
:CALCulate:EVM:EQUalizer:TMODe?	Query equalization method
:CALCulate:EVM:PILOt:TRACk:AMPLitude OFF ON 0 1	Set amplitude tracking
:CALCulate:EVM:PILOt:TRACk:AMPLitude?	/Query amplitude tracking
:CALCulate:EVM:PILOt:TRACk:PHASe OFF ON 0 1	Set phase tracking
:CALCulate:EVM:PILOt:TRACk:PHASe?	Query phase tracking
:CALCulate:MARKer[1] 2--12:X <freq time>	Marker X-axis
:CALCulate:MARKer[1] 2--12:X?	Marker X-axis
:CALCulate[1] 2--6:MARKer[1] 2--12:MAXimum	Peak Search
:CONFigure:STANdard <Standard>	Set protocol standards
:CONFigure:STANdard?	Query protocol standards
:CONFigure:WLAN:RUConfig:HEPPdu <RUConfig_PPDU>	Set PPDU format
:CONFigure:WLAN:RUConfig:HEPPdu?	Query PPDU format
:DISPlay:WINDow[1] 2--7:TRACe:Y:SPACing LINear LOGarithmic	SetAmplitudeScaleType
:DISPlay:WINDow[1] 2--7:TRACe:Y:SPACing?	QueryAmplitudeScaleType
:DISPlay[:WINDow[1] 2--7]:TRACe:Y[:SCALe] <level>	Setting reference values
:DISPlay[:WINDow[1] 2--7]:TRACe:Y[:SCALe]:AUTO ONCE	Auto Scaling
:DISPlay[:WINDow[1] 2--7]:TRACe:Y[:SCALe]:PDIVision <pdivision>	SetScalePDiv
:DISPlay[:WINDow[1] 2--7]:TRACe:Y[:SCALe]:PDIVision?	QueryScalePDiv
:DISPlay[:WINDow[1] 2--7]:TRACe:Y[:SCALe]:RLEVel <rlevel>	Set reference level
:DISPlay[:WINDow[1] 2--7]:TRACe:Y[:SCALe]:RLEVel:OFFSet <offset>	Set reference level offset
:DISPlay[:WINDow[1] 2--7]:TRACe:Y[:SCALe]:RLEVel:OFFSet?	Query reference level offset
:DISPlay[:WINDow[1] 2--7]:TRACe:Y[:SCALe]:RLEVel?	Query reference level
:DISPlay[:WINDow[1] 2--7]:TRACe:Y[:SCALe]:RPOStion UP MID DOWN	Set reference position
:DISPlay[:WINDow[1] 2--7]:TRACe:Y[:SCALe]:RPOStion?	Query reference position
:DISPlay[:WINDow[1] 2--7]:TRACe:Y[:SCALe]?	Query reference value
:INITiate:CONTInuous OFF ON 0 1	Set sweep mode
:INITiate:CONTInuous?	Query sweep mode
:INPut:ATTenuation <value>	Set the value of the mechanical attenuator
:INPut:ATTenuation:AUTO OFF ON 0 1	Set mechanical attenuator Auto/Manual state

## Annex B Zoom table of SCPI commands

:INPut:ATTenuation:AUTO:MODE 2dB 10dB	Set mechanical attenuator step
:INPut:ATTenuation:AUTO:MODE?	Query mechanical attenuator step
:INPut:ATTenuation:AUTO?	Query mechanical attenuator Auto/Manual state
:INPut:ATTenuation?	Query value of mechanical attenuation
:INPut:GAIN:STATe	QueryPreAmpSwitch
:INPut:GAIN:STATe OFF ON 0 1	SetPreAmpSwitch
:INPut[1]:EATT <level>	Set value of electronic attenuator
:INPut[1]:EATT?	Query value of the electronic attenuator
:LAYout:ADD <windowtype>	Add Window
:LAYout:IDENTify[:WINDow]? <windowtype>	Query window ID
:LAYout::WINDow[1][2--6]:REMOve	Delete window
:TRIGger[:SEQuence]:TIME:RINTerval?	Query timing cycle (Time Trigger)
:TRIGger[:SEQuence]:HOLDoff?	Query trigger delay (video trigger, external trigger)
:TRIGger[:SEQuence]:HOLDoff <time>	Set trigger delay (video trigger, external trigger)
:TRIGger[:SEQuence]:IFPower:HOLDoff:STATe OFF ON 0 1	Set trigger block ON/OFF
:TRIGger[:SEQuence]:IFPower:HOLDoff:STATe?	Query trigger block ON/OFF
:TRIGger[:SEQuence]:IFPower:HOLDoff <Time>	Set trigger OFF time
:TRIGger[:SEQuence]:IFPower:HOLDoff?	Query trigger block time
:TRIGger[:SEQuence]:LEVel:IFPower <ampl>	Set trigger level (video trigger)
:TRIGger[:SEQuence]:LEVel:IFPower?	Query trigger level (video trigger)
:TRIGger[:SEQuence]:LEVel:RFPower <Level>	Set trigger level (Burst trigger)
:TRIGger[:SEQuence]:LEVel:RFPower?	Query trigger level (Burst trigger)
:TRIGger[:SEQuence]:LEVel[:EXTeral[1]][2 3] <level>	Set trigger level (external trigger)
:TRIGger[:SEQuence]:LEVel[:EXTeral[1]][2 3]?	Query trigger level (external trigger)
:TRIGger[:SEQuence]:SLOPe POSitive NEGative	Set trigger slope
:TRIGger[:SEQuence]:SLOPe?	Query trigger slope
:TRIGger[:SEQuence]:SOURce <source>	Set trigger mode
:TRIGger[:SEQuence]:SOURce?	Query trigger mode
:TRIGger[:SEQuence]:TIME:RINTerval <time>	Set timing cycle (Time Trigger)
[:SENSe]:AVERage:TCONtrol EXPonential REPeat	Set the average mode
[:SENSe]:AVERage:TCONtrol?	Query average mode
[:SENSe]:AVERage:COUNT <integer>	Set average times
[:SENSe]:AVERage:COUNT?	Query average times

**Annex B Zoom table of SCPI commands**

[:SENSe]:AVERAge[:STATe] ON OFF 1 0	SetAvgOn
[:SENSe]:AVERAge[:STATe]?	QueryAvgOn
[:SENSe]:DEMod:FFT:OFFSet <Mode>	Set FFT offset
[:SENSe]:DEMod:FFT:OFFSet?	Query FFT offset
[:SENSe]:DEMod:FILTer:EFLength <length>	Set filter length
[:SENSe]:DEMod:FILTer:EFLength?	Query filter length
[:SENSe]:FREQuency:CENTer <frequency>	Set center frequency
[:SENSe]:FREQuency:CENTer?	Query center frequency
[:SENSe]:FREQuency:SPAN <Span>	Set signal bandwidth
[:SENSe]:FREQuency:SPAN?	Query signal bandwidth
[:SENSe]:TRACking:IQComp?	IQ mismatch compensation ON/OFF
[:SENSe]:TRACking:IQComp[:STATe] ON OFF 1 0	Set IQ mismatch compensation ON/OFF
[:SENSe]:SWAPiq[:STATe] ON OFF 1 0	Set IQ exchange ON/OFF
[:SENSe]:SWAPiq[:STATe]?	Query IQ exchange ON/OFF
[:SENSe<n>]:SWEep:TIME <Time>	Set capture time
[:SENSe<n>]:SWEep:TIME?	Query capture time

**Table 15 SCPI zoom table for multi carrier group delay**

Command	Function
:CALCulate:GRPDelay:MODE ABSolute RELative	Set group delay mode
:CALCulate:GRPDelay:MODE?	Query group delay mode
:CALCulate[1] 2--7:MARKer:AOff	Delete all markers
:CALCulate[1] 2--7:MARKer[1] 2--12:MAXimum	Set peak search
:CALCulate[1] 2--7:MARKer[1] 2--12:MAXimum:LEFT	Set left peak
:CALCulate[1] 2-7:MARKer[1] 2-12:MAXimum:NEXT	Set sub peak
:CALCulate[1] 2--7:MARKer[1] 2--12:MAXimum:RIGHT	Set right peak
:CALCulate[1] 2--7:MARKer[1] 2--12:MODE POSition DELTA FIXed OFF	Set marker mode
:CALCulate[1] 2--7:MARKer[1] 2--12:MODE?	Query marker mode
:CALCulate[1] 2--7:MARKer[1] 2--12:REFerence <n>	Set reference marker
:CALCulate[1] 2--7:MARKer[1] 2--12:REFerence?	Query reference marker
:CALCulate[1] 2--7:MARKer[1] 2--12:X <freq>	Marker X-axis
:CALCulate[1] 2--7:MARKer[1] 2--12:X?	Query X-axis marker values
:CALCulate[1] 2--7:MARKer[1] 2--12:Y <value>	Fixed marker Y-axis

## Annex B Zoom table of SCPI commands

:CALCulate[1][2--7]:MARKer[1][2--12]:Y?	Query the value of axis X marker
:CALibration:MCGD	Perform calibration
:CALibration:MCGD:STATe?	Query the calibration state
:CONFigure:GENerator:CONNection:CSTate?	Signal source connection state query
:CONFigure:GENerator:CONNection:CSTate?	Query the connection state of signal source
:CONFigure:GENerator:IPConnection:ADDRess <S >	Set signal source IP and connect
:CONFigure:GENerator:MCGD:CARRier:COUNT:STATe?	Query carrier number control ON/OFF
:CONFigure:GENerator:MCGD:CARRier:COUNT[:STATe] ON OFF 1 0	Set carrier number control ON/OFF
:CONFigure:GENerator:MCGD:CARRier:SPACing[:STATe] ON OFF 1 0	Set carrier spacing control ON/OFF
:CONFigure:GENerator:MCGD:CARRier:SPACing[:STATe]?	Query carrier spacing control ON/OFF
:CONFigure:GENerator:MCGD:CONTRol[:STATe] ON OFF 1 0	Set signal source control ON/OFF
:CONFigure:GENerator:MCGD:CONTRol[:STATe]?	Query signal source control ON/OFF
:CONFigure:GENerator:MCGD:FREQuency:CENTer[:STATe] ON OFF 1 0	Set center frequency control ON/OFF
:CONFigure:GENerator:MCGD:FREQuency:CENTer[:STATe]?	Query center frequency control ON/OFF
:CONFigure:GENerator:RFOutput[:STATe] ON OFF 1 0	Set RF output to ON/OFF state
:CONFigure:GENerator:RFOutput[:STATe]?	Query RF output ON/OFF
:DISPlay[:WINDow[1][2--7]:TRACe[1][2--6]:STATe] ON OFF 1 0	Set Display Hide Method
:DISPlay[:WINDow[1][2--7]:TRACe[1][2--6]:STATe]?	Query Display Hide Method
:DISPlay[:WINDow[1][2--7]:TRACe[1][2--6]:MODE WRITe AVERAge MAXHold MINHold	Set trace display mode
:DISPlay[:WINDow[1][2-7]:TRACe[1][2-6]:MODE?	Query trace display mode
:DISPlay[:WINDow[1][2-7]:TRACe[1][2-6]:Y:SPACing LOGarithmic LINear	SetAmplitudeScaleType
:DISPlay[:WINDow[1][2-7]:TRACe[1][2-6]:Y:SPACing?	QueryAmplitudeScaleType
:DISPlay[:WINDow[1][2-7]:TRACe[1][2-6]:Y[:SCALE]:AUTO ONCE	Auto scaling (single)
:DISPlay[:WINDow[1][2--7]:TRACe[1][2--6]:Y[:SCALE]:PDIVision <amp>	Set scale/division
:DISPlay[:WINDow[1][2-7]:TRACe[1][2-6]:Y[:SCALE]:PDIVision?	Query scale/division
:DISPlay[:WINDow[1][2--7]:TRACe[1][2--6]:Y[:SCALE]:RLEVel <amp>	Set reference level
:DISPlay[:WINDow[1][2--7]:TRACe[1][2--6]:Y[:SCALE]:RLEVel:OFFSet <offset>	Set reference level offset
:DISPlay[:WINDow[1][2-7]:TRACe[1][2-6]:Y[:SCALE]:RLEVel:OFFSet?	Query reference level offset
:DISPlay[:WINDow[1][2-7]:TRACe[1][2-6]:Y[:SCALE]:RLEVel?	Query reference level

## Annex B Zoom table of SCPI commands

:DISPlay[:WINDow[1]]2--7]:TRACe[1]]2--6:Y[:SCALe]:RPOStion UP MID DOWN	Set reference position of vertical axis
:DISPlay[:WINDow[1]]2-7]:TRACe[1]]2-6:Y[:SCALe]:RPOStion?	Query reference position of vertical axis
:DISPlay[:WINDow[1]]2--7]:TRACe[1]]2--6:Y[:SCALe]:RVALue	Setting reference values
:DISPlay[:WINDow[1]]2--7]:TRACe[1]]2--6:Y[:SCALe]:RVALue?	Query reference value
:INITiate:CONTInuous OFF ON 0 1	Set Sweep Single Continuous
:INITiate:CONTInuous?	Query Sweep Single Continuous
:INPut:ATTenuation:STEP 2DB 10DB	Set mechanical attenuator step
:INPut:ATTenuation:STEP?	Query mechanical attenuator step
:INPut[1]]2:ATTenuation <Attenuation>	Set mechanical attenuator Auto/Manual
:INPut[1]]2:ATTenuation:AUTO OFF ON 0 1	Set mechanical attenuation value
:INPut[1]]2:ATTenuation:AUTO?	Query mechanical attenuator value
:INPut[1]]2:ATTenuation?	Query mechanical attenuator Auto/Manual
:INPut[1]]2:EATT <amp>	Set electronic attenuator value
:INPut[1]]2:EATT?	Query electronic attenuator value
:INPut[1]]2:GAIN:STATe OFF ON 0 1	SetPreAmpSwitch
:INPut[1]]2:GAIN:STATe?	QueryPreAmpSwitch
:LAYout:ADD MAGNitude PHAsE MCDelay REFMagnitude REFPhase GAIN DIFFPhase	Add Window
:LAYout:CATalog[:WINDow]?	Query all window types
:LAYout:REMOve MAGNitude PHAsE MCDelay REFMagnitude REFPhase GAIN DIFFPhase	Delete window
:MMEMory:LOAD:MCGD:RCALibration <S>	Input calibration data
:MMEMory:STORe[1]]2--6:MCGD:RCALibration <S>	Save calibration data
:TRIGger[:SEQuence]:HOLDoff[:TIME] <Time>	Trigger delay time
:TRIGger[:SEQuence]:HOLDoff[:TIME]?	Trigger delay time
:TRIGger[:SEQuence]:IFPower:HOLDoff <Time>	Trigger Blocking
:TRIGger[:SEQuence]:IFPower:HOLDoff?	Trigger Blocking
:TRIGger[:SEQuence]:LEVel:IFPower <Level>	Trigger Level (Power Trigger)
:TRIGger[:SEQuence]:LEVel:IFPower?	Trigger Level (Power Trigger)
:TRIGger[:SEQuence]:LEVel:RFPower <Level>	Trigger Level (Burst Trigger)
:TRIGger[:SEQuence]:LEVel:RFPower?	Trigger Level (Burst Trigger)
:TRIGger[:SEQuence]:LEVel[:EXTernal[1]]2--3] <Level>	Trigger Level (External Trigger 1, 2 & 3)

## Annex B Zoom table of SCPI commands

:TRIGger[:SEQuence]:LEVel[:EXTeRnal[1]][2--3]?	Trigger Level (External Trigger 1, 2 & 3)
:TRIGger[:SEQuence]:SLOPe POSitive NEGative	Trigger polarity
:TRIGger[:SEQuence]:SLOPe?	Trigger polarity
:TRIGger[:SEQuence]:SOURce IMMEDIATE EXTeRnal[1]  EXTeRnal[2]  EXTeRnal[3]  RFPower TIME VIDeo	Trigger mode
:TRIGger[:SEQuence]:SOURce?	Trigger mode
:TRIGger[:SEQuence]:TIME:RINteRval <Time>	Cycle (cycle Time Trigger)
:TRIGger[:SEQuence]:TIME:RINteRval?	Cycle (cycle Time Trigger)
[:SENSe]:CARRier:COUNT <integer>	Set the number of carriers
[:SENSe]:CARRier:COUNT?	Query the number of carriers
[:SENSe]:CARRier:SPACing?	Query carrier spacing
[:SENSe]:CARRier:SPACing<freq>	Set carrier spacing
[:SENSe]:CESTimation:MODE CARRiers OFFSet OFF	Set carrier estimation mode
[:SENSe]:CESTimation:MODE?	Query carrier estimation mode
[:SENSe]:FREQuency:CENTer <freq>	Set center frequency
[:SENSe]:FREQuency:CENTer:STEP <freq>	Set the frequency step value
[:SENSe]:FREQuency:CENTer:STEP:AUTO OFF ON 0 1	Set Freq Step Auto/Man
[:SENSe]:FREQuency:CENTer:STEP:AUTO?	Query Freq Step Auto/Man
[:SENSe]:FREQuency:CENTer:STEP?	Query the frequency step value
[:SENSe]:FREQuency:CENTer?	Query center frequency
[:SENSe]:FREQuency:SPAN <freq>	Set carrier bandwidth
[:SENSe]:FREQuency:SPAN?	Query carrier bandwidth
[:SENSe]:MTIME:AUTO ON OFF 1 0	Set capture time
[:SENSe]:MTIME:AUTO?	Query capture time
[:SENSe]:POWER[:RF]:MIXer:RANGe[:UPPer] <power>	Set maximum mixing level value
[:SENSe]:POWER[:RF]:MIXer:RANGe[:UPPer]?	Query maximum mixing level value
[:SENSe]:SWEep:COUNT <integer>	Set sweep times
[:SENSe]:SWEep:COUNT?	Query sweep times

Table 16 Local error message

Failure code	Key failure field	Description
0	No error	No error
-100	Command error	Command error
-101	Invalid character	Invalid character
-102	Syntax error	Command with parameter not allowed
-103	Invalid separator	Invalid separator
-104	Data type error	Data type error
-105	GET not allowed	GET not allowed
-108	Parameter not allowed	Parameter not allowed
-109	Missing parameter	Missing parameter
-110	Command header error	Command header error
-111	Header separator error	Header separator error
-112	Program mnemonic too long	Program mnemonic too long
-113	Undefined header	Undefined command
-113	Undefined header	Keywords with figures not allowed
-114	Header suffix out of range	Header suffix out of range
-115	Unexpected number of parameters	Incorrect number of parameters
-120	Numeric data error	Value data error
-121	Invalid character in number	Invalid character in number
-123	Exponent too large	Exponent too large
-124	Too many digits	Too many digits
-128	Numeric data not allowed	Numeric data not allowed
-130	Suffix error	Suffix error
-131	Invalid suffix	Invalid suffix
-134	Suffix too long	Suffix too long
-138	Suffix not allowed	Suffix not allowed
-140	Character data error	Character data error
-141	Invalid character data	Invalid character data
-144	Character data too long	Character data too long
-148	Character data not allowed	Character data not allowed
-150	String data error	String data error

## Annex C Zoom table of failure information

-151	Invalid string data	Invalid string data
-158	String data not allowed	String data not allowed
-160	Block data error	Block data error
-161	Invalid block data	Invalid block data
-168	Block data not allowed	Block data not allowed
-170	Expression error	Expression error
-171	Invalid expression	Invalid expression
-178	Expression data not allowed	Expression data not allowed
-180	Macro error	Macro error
-181	Invalid outside macro definition	Invalid external micro definition
-183	Invalid inside macro definition	Invalid internal micro definition
-184	Macro parameter error	Macro parameter error
-200	Execution error	Execution error
-201	Invalid while in local	Invalid local state
-202	Settings lost due to rtl	Setting is lost because it goes back to local
-203	Execution error	Execution error
-210	Trigger error	Trigger error
-211	Trigger ignored	Trigger ignored
-212	Arm ignored	Arm ignored
-213	Init ignored	Initialization ignored
-214	Trigger deadlock	Trigger deadlock
-215	Arm deadlock	Arm locked
-220	Parameter error	Parameter error
-221	Settings conflict	Settings conflict
-222	Data out of range	Data out of range
-223	Too much data	Too much data
-224	Illegal parameter value	Illegal parameter value
-225	Out of memory	Out of memory
-226	Lists not same length	List length is different
-230	Data corrupt or stale	Data damaged or invalid
-231	Data questionable	Data suspected
-232	Invalid format	Invalid format
-233	Invalid version	Invalid version

**Annex C Zoom table of failure information**

-240	Hardware error	Hardware error
-241	Hardware missing	Hardware missing
-250	Mass storage error	Mass storage error
-251	Missing mass storage	Lack block storage
-252	Missing media	Lack media
-253	Corrupt media	Media damaged
-254	Media full	Media full
-255	Directory full	Disk full
-256	File name not found	File name not found
-257	File name error	File name error
-258	Media protected	Protected media
-260	Expression error	Expression error
-261	Math error in expression	Computing errors in expressions
-270	Macro error	Macro error
-271	Macro syntax error	Syntax error
-280	Program error	Program error
-281	Cannot create program	Cannot create programs
-282	Illegal program name	Illegal program name
-283	Illegal variable name	Illegal variable name
-284	Program currently running	Program is running
-285	Program syntax error	Program syntax error
-286	Program runtime error	Program running error
-290	Memory use error	Memory usage error
-291	Out of memory	Out of memory
-292	Referenced name does not exist	Reference name does not exist
-293	Referenced name already exists	Reference name already exists
-294	Incompatible type	Type incompatible
-300	Device-specific error	Out of memory
-310	System error	System error
-311	Memory error	Memory error
-312	PUD memory lost	PUD memory loss
-313	Calibration memory lost	Lost calibration memory
-314	Save/recall memory lost	Loss of memory for storage/call





## Annex C Zoom table of failure information

-340	Calibration failed	Error in absolute amplitude error calibration when 500MHz broadband preamplifier is ON!
-340	Calibration failed	Error in absolute amplitude error calibration of 500MHz narrow band!
-340	Calibration failed	Error in absolute amplitude error calibration when 500MHz narrowband preamplifier is ON!
-340	Calibration failed	Error in absolute amplitude error calibration of 500MHz broadband!
-340	Calibration failed	Error in absolute amplitude error calibration when 500MHz broadband preamplifier is ON!
-340	Calibration failed	Error in absolute amplitude error calibration of 500MHz narrow band!
-340	Calibration failed	9600MHz narrowband preselector bypass open absolute amplitude error calibration error!
-340	Calibration failed	Error in absolute amplitude error calibration when 500MHz narrowband preamplifier is ON!
-340	Calibration failed	9600MHz narrowband Preamplifier ON Preselector bypass ON Absolute amplitude Error calibration error!
-340	Calibration failed	Error in absolute amplitude error calibration of 500MHz broadband!
-340	Calibration failed	Error in absolute amplitude error calibration when 500MHz broadband preamplifier is ON!
-340	Calibration failed	500MHz bandwidth 40MHz phase noise optimization ON RF preselector bypass ON Absolute amplitude Error calibration error!
-340	Calibration failed	500MHz bandwidth 40MHz phase noise optimization OFF RF preselector bypass ON Absolute amplitude Error calibration error!
-340	Calibration failed	500MHz bandwidth 40MHz phase noise optimization OFF RF preselector bypass OFF Absolute amplitude Error calibration error!
-340	Calibration failed	500MHz bandwidth 400MHz RF preselector bypass ON Absolute amplitude Error calibration error!
-340	Calibration failed	500MHz bandwidth 400MHz RF preselector bypass OFF Absolute amplitude Error calibration error!
-340	Calibration failed	500MHz bandwidth 400MHz RF preselector bypass ON Absolute amplitude Error calibration error!
-340	Calibration failed	500MHz bandwidth 400MHz RF preselector bypass OFF Absolute amplitude Error calibration error!
-340	Calibration failed	500MHz bandwidth 400MHz RF preselector bypass ON Absolute amplitude Error calibration error!
-340	Calibration failed	500MHz bandwidth 400MHz RF preselector bypass OFF Absolute amplitude Error calibration error!
-340	Calibration failed	9600MHz Bandwidth 40MHzYTF bypass ON Absolute amplitude Error

**Annex C Zoom table of failure information**

		calibration error!
-340	Calibration failed	9600MHz Bandwidth 40MHzYTF bypass OFF Absolute amplitude Error calibration error!
-340	Calibration failed	9600MHz Bandwidth 400MHzYTF bypass ON Absolute amplitude Error calibration error!
-340	Calibration failed	9600MHz Bandwidth 1200MHzYTF bypass ON Absolute amplitude Error calibration error!
-340	Calibration failed	9600MHz Bandwidth 2000MHzYTF bypass ON Absolute amplitude Error calibration error!